



Faster, Safer, Easier
Endura is your productivity partner

Ваш поставщик:
ООО "КОМПАНИЯ ОПТУЛС"
Москва, ул.Иловайская, д.3
Тел.: +7 (495) 646-00-96
sale@opttools.ru
www.opttools.ru

ENDURA®



INDUSTRY TOOLS CATALOG

PROFESSIONAL TOOLS

Endura-Greenlee Tools (Shanghai) Co., Ltd.
Add: RM201, NO455 Fushan Road, Shanghai, China (200122)
Tel: 0086-21-58953880 58956557 58958103
Fax: 0086-21-51062680 58955766
E-mail: export@enduratools.com
www.ENDURA-Greenlee.com



Wechat Service no.
EnduraGreenlee



Wechat Subscription no.
Endura-Greenlee

2016

ISO 9001
Quality management
System

Faster, Safer, Easier
Endura is your productivity partner



www.ENDURA-Greenlee.com



Faster, Safer, Easier
Endura is your productivity partner



ENDURA[®]



www.ENDURA-Greenlee.com





ENDURA®

Established in 1998, Endura is a professional tools brand in Shanghai, China, specializing in designing, manufacturing and marketing various kinds of hand tools which are widely used in machine repair, construction & renovation, auto maintenance, property management, plant installation and individual service. After 15 years' development, Endura has become one of the leading brands of tool kits for Chinese industrial & mining enterprises. Now Endura are steady partners of many famous companies.

Endura-Greenlee Tools (Shanghai) Co., Ltd. is a subsidiary of Textron (Fortune 500). Textron Inc. (NYSE:TXT) is not only one of the world's best known multi-industry companies, it is a pioneer of the diversified business model. Founded in 1923, Textron has grown into a network of business with total revenues of \$12.2 billion, and approximately 33,000 employees with facilities and presence in 25 countries, serving a diverse and global customer base. Head quartered in Providence, Rhode Island, U.S.A., Textron is ranked 236th on the FORTUNE 500 list of largest U.S. companies.

Driven by the spirit of innovation, Endura today offers more than 3,000 products, all tools meet international standards as well as Chinese GB standard. Supported by Textron and Greenlee's strong sale network and advanced management strength, Endura is the right best to meet your needs, tailors the perfect solution for you.

Faster, Safer, Easier- Endura is your productivity partner.



GREENLEE® A Textron Company

Greenlee is the biggest cable installation solution provider in the world. The brand established in 1862 by Robert and Ralph brothers in Chicago, USA. After 150 years development, Greenlee is now the first choice of tools and global leader in the industry of cable installation and testing.

Greenlee joined Textron in 1986, now Textron has 5 sections: Bell Helicopter, Cessna Aviation, Textron Industrial, Textron Financial and Textron Systems. Among them, Greenlee is Textron Industrial's critical tool brand.

The success of Greenlee's Professional hand tools continues to grow with an ever larger collection of products. Each Greenlee hand tool is "Made for the Trade" and each kit has been carefully assembled to meet the demanding requirements of today's professional electrical contractor.



ENDURA®

Established in 1998, professional tools in Shanghai, China. Widely used in machine repair in plant, construction & maintenance, auto repair, property management and individual service.



GREENLEE® A Textron Company

Established in 1862, by Robert and Ralph Greenlee Chicago, USA. After 150 years, today it is the world's biggest cable installation and test equipment provider.



TEXTRON

Founded in 1923 (NYSE: TXT), one of the world's best known multi-industry companies, a pioneer of the diversified business model, ranked 236th on the Fortune 500 list of largest U.S. companies.



GREENLEE COMMUNICATIONS A Textron Company

Greenlee Communications

Greenlee's Communication brands: Tempo, Paladin etc. are integrated into a new brand: Greenlee communications, which integrates famous brand power and expertise communication industry.

■ Factory



■ Marketing



■ Office



■ Website



■ Show Room and Training Room



■ Display Van





ENDURA AND STANDARDS







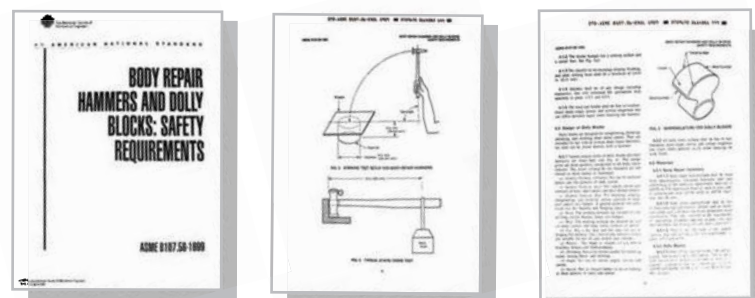











Endura is committed to continuously improve from quality, introducing new technology and updating and actively improve Endura enterprise standards based on international standards.

Endura drives product innovation and continuously confirms to ISO 9001 and the promise of customer satisfaction.

ENDURA Refers Standards:
 International Standards(ISO)
 China Standards (GB)
 German Standards (DIN)
 American Standards (ANSI)



INDEX

1 Roller Cabinets & Work Furnitures	2	
2 Tool Boxes & Tool Bags	12	
3 Tools Sets	17	
4 Hand Sockets & Driver Tools	27	
5 Wrenches	38	
6 Screwdriver & Bits	47	
7 Pliers	59	
8 Hex Keys	65	
9 Torque Tools	70	
10 Insulated Tools	78	
11 Pneumatic Tools	87	
12 Workshop Equipments	91	
13 Precision Tools	94	
14 Drilling Tools	98	
15 Abrasive Products	104	
16 Welding Tools	106	
17 Construction Tools	109	
18 Cutting Tools	112	
19 Pipe Tools	117	
20 Safety Tools	122	
21 Electrical Tools	125	
22 Hammer & Striking Tools	134	
23 Hoist Tools	138	
24 Auto Maintenance & Repair Tools	139	
25 Flashlights	150	



1

ROLLER CABINETS & WORK FURNITURES

11 TRAY TOOL CHESTS

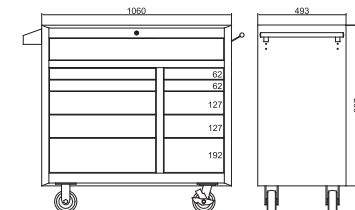

- 1 – Drawers, 953x445x120mm
- 2 – Drawers, 573x445x62mm
- 2 – Drawers, 573x445x127mm
- 1 – Drawers, 573x445x192mm
- 2 – Drawers, 289x445x62mm
- 2 – Drawers, 289x445x127mm
- 1 – Drawers, 289x445x192mm

- 11 drawers
- Made of cold-rolled steel plate; easy to pull and push.
- Casters bearing heavy weight.

PART #	LxWxH	ΔΔ	☐
E8160	1060x493x897mm	105.0kg	1

20 TRAY TOOLS CHESTS

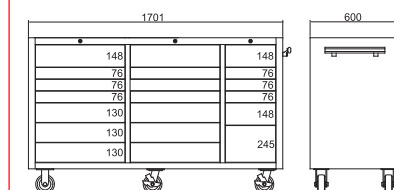

- 2-Drawers, 598x565x148mm
- 6-Drawers, 598x565x76mm
- 6-Drawers, 598x565x130mm
- 2-Drawers, 336x565x148mm
- 3-Drawers, 336x565x76mm
- 1-Drawers, 336x565x245mm

- 20 Drawers
- Made of stainless steel, easy to pull and push
- Casters bearing heavy weight

PART #	LxWxH	ΔΔ	☐
E8165	1700x600x870	150kg	1

OEM Service

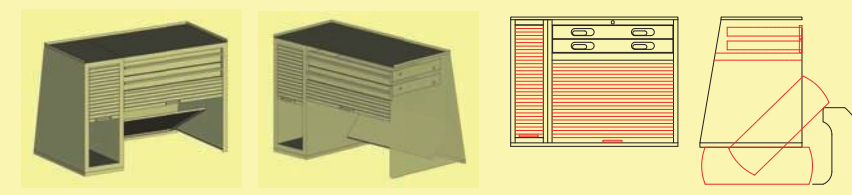

Hexagonal Work Table

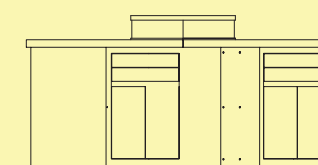
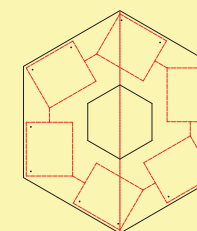

Work Table

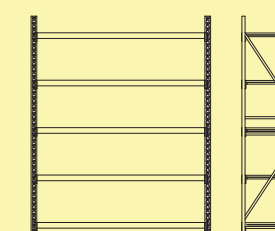
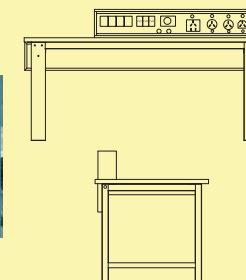

Shelf



4 TRAY TOOL CHEST

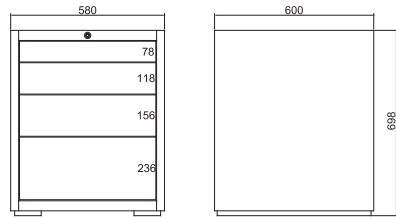

4-Drawers

- 1-Drawers, 468x467x78mm
- 1-Drawers, 468x467x118mm
- 1-Drawers, 468x467x156mm
- 1-Drawers, 468x467x236mm

PART #	SIZE	LxWxH	ΔTΔ	1
E8164	550x600x700mm			1
E8164A	with wheels 550x600x700mm			1

6 TRAY TOOL CARTS

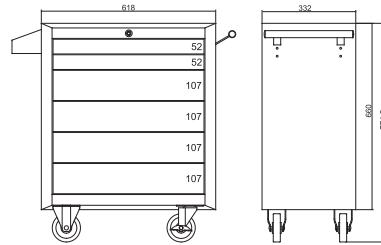

2-Drawers, 516x282x52mm
4-Drawers, 516x282x107mm

- 6 drawers
- Made of cold-rolled steel plate; easy to pull and push.
- Casters bearing heavy weight.

PART #	LxWxH	ΔTΔ	1
E8147A	618x330x662mm	38.5kg	1

6 TRAY TOOL CARTS

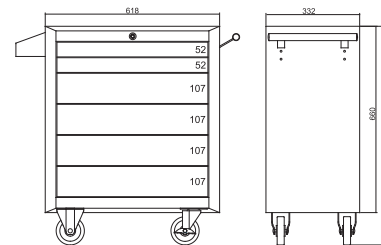

2-Drawers, 516x282x52mm
4-Drawers, 516x282x107mm

- 6 drawers
- Made of cold-rolled steel plate; easy to pull and push.
- Casters bearing heavy weight.

PART #	LxWxH	ΔTΔ	1
E8147	618x330x662mm	38.5kg	1

4 TRAY TOOL CHESTS

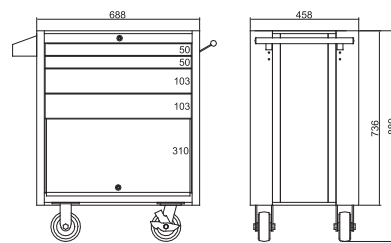

2-Drawers, 597x412x50mm
2-Drawers, 597x412x103mm

- 4 drawers and 1 underpan.
- Made of cold-rolled steel plate; easy to pull and push.
- Casters bearing heavy weight.

PART #	LxWxH	ΔTΔ	1
E8148	688x458x736mm	55.4kg	1

6 TRAY TOOL CHESTS

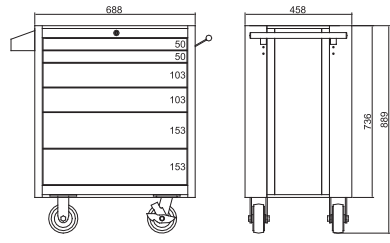

2-Drawers, 597x412x50mm
2-Drawers, 597x412x103mm
2-Drawers, 597x412x153mm

- 6 drawers
- Made of cold-rolled steel plate; easy to pull and push.
- Casters bearing heavy weight.

PART #	LxWxH	ΔTΔ	1
E8149	688x458x736mm	66.5kg	1

ENDURA®
A Textron Company

7 TRAY TOOL CARTS

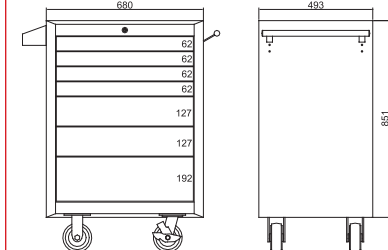

4-Drawers, 573x445x62mm
2-Drawers, 573x445x127mm
1-Drawers, 573x445x192mm

- White color
- 7 Drawers
- Made of cold-rolled steel plate, easy to pull and push
- Casters bearing heavy weight

PART #	LxWxH	ΔTΔ	1
E8151W	680x493x851mm	72kg	1

7 TRAY TOOL CARTS

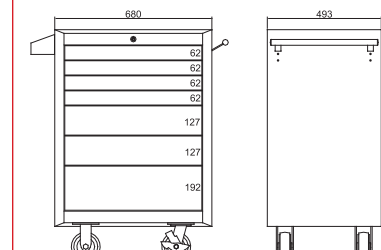

4-Drawers, 573x445x62mm
2-Drawers, 573x445x127mm
1-Drawers, 573x445x192mm

- 7 drawers
- Made of cold-rolled steel plate; easy to pull and push.
- Casters bearing heavy weight.

PART #	LxWxH	ΔTΔ	1
E8151A	680x493x851mm	72.0kg	1

7 TRAY TOOL CARTS

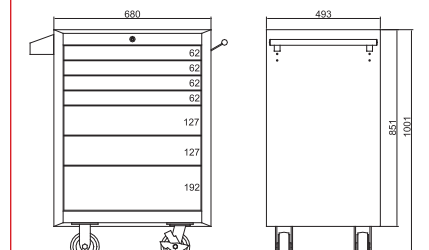

4-Drawers, 573x445x62mm
2-Drawers, 573x445x127mm
1-Drawers, 573x445x192mm

- 7 drawers
- Made of cold-rolled steel plate; easy to pull and push.
- Casters bearing heavy weight.

PART #	LxWxH	ΔTΔ	1
E8151	680x493x851mm	72.0kg	1

7 TRAY TOOL CARTS



Drawer handle with PVC strip to list contents of drawer.

Protective liner in every drawer.

Full extension ball bearing slides.

Heavy swivel caster and thickening body

6 TRAY TOOL CHESTS

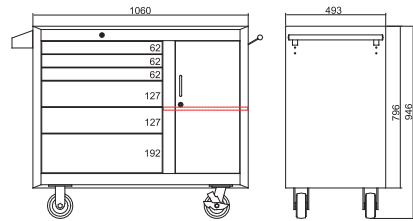

- 3—Drawers, 573X445X62mm
- 2—Drawers, 573X445X127mm
- 1—Drawers, 573X445X192mm
- 6 drawers, 1 side cabinet.
- Made of cold-rolled steel plate; easy to pull and push.
- Casters bearing heavy weight.

PART #	LxWxH	△△△	🔧
E8150	1060x493x796mm	85.0kg	1

8 TRAY TOOL CHEST

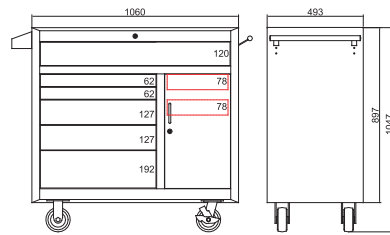

- 1—Drawers, 953x445x120mm
- 2—Drawers, 573x445x62mm
- 2—Drawers, 573x445x127mm
- 1—Drawers, 572x445x192mm
- 2—Drawers, 432x312x78mm
- 8 drawers
- Made of cold-rolled steel plate; easy to pull and push.
- Casters bearing heavy weight.

PART #	LxWxH	△△△	🔧
E8150A	1060x493x897mm	95.0kg	1

TOOL CHEST

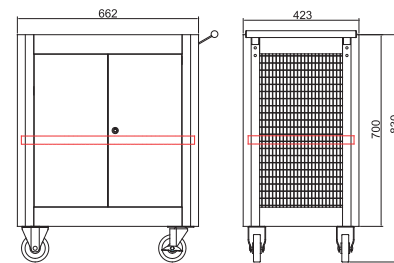

- Totally gray
- two door design with lock and safe
- Toolkit has 3 layer to classify tools
- Caster bear heavy weight

PART #	LxWxH	△△△	🔧
E8159A	662x423x700	21.8kg	1

3 TRAY TOOL CARTS

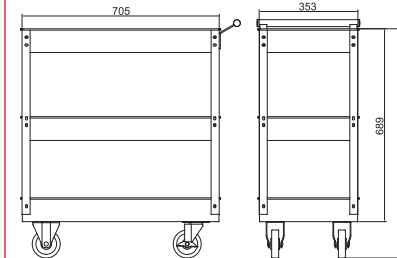

- 3-Layer drawers, store and move the tools easily.

PART #	LxWxH	△△△	🔧
E8146	705x351x689mm	13.0kg	1

TOOL CARTS

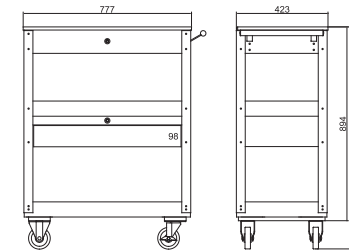

- Made of cold-rolled steel plate; easy to pull and push.
- Full high-grade ball bearing slides.
- Extra volume for more storage.

PART #	LxWxH	△△△	🔧
E8152	770x420x885mm	31.8kg	1

TOOL CARTS

□ Box with Hydraulic Bracing and Lock



Large Tray for big tools

TOOL CARTS

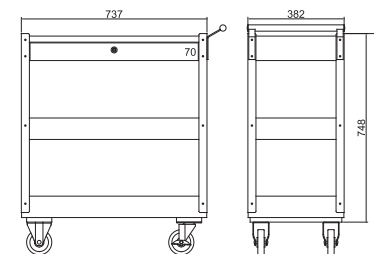

- 1-Drawers 646x357x70mm
- Made of cold-rolled steel plate; easy to pull and push.
- 2-Casters could be directed and with brake.
- 3-Layer drawers, store and move the tools easil.

PART #	LxWxH	△△△	🔧
E8157	735x380x728mm	23.0kg	1

TOOL CARTS

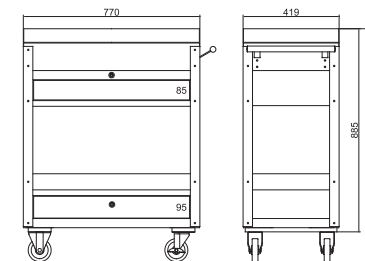

- 1-Drawers 660x376x85mm
- 1-Drawers 660x376x95mm
- Full high-grade ball bearing slides.
- Easy to pull and push.
- 2-Casters could be directed and with brake.
- Sheet steel reinforced for long-life usage.

PART #	LxWxH	△△△	🔧
E8154	770x420x875mm	44.5kg	1

□ Sliding Mode to Save Space



□ Large Tray for big tools



• ENDURA provides OEM tool boxes and tool trolleys to meet customized requirements.

6 TRAY TOOL CHESTS

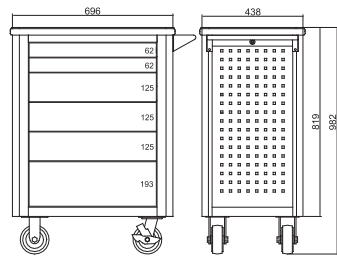

- 2 – Drawers, 531x397x62mm
- 3 – Drawers, 531x397x125mm
- 1 – Drawers, 531x397x193mm

- 6 drawers
- Made of cold-rolled steel plate; easy to pull and push.
- Casters bearing heavy weight.
- Flank with holes to hang tools.

PART #	LxWxH	△△△	🗑️
E8196	696x438x819mm	70.0kg	1

4 TRAY TOOL CHESTS

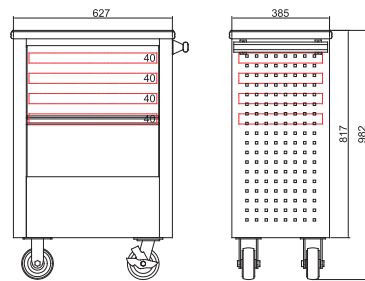

- 4 – Drawers, 504x330x40mm

- 4 drawers
- Made of cold-rolled steel plate; easy to pull and push.
- Casters bearing heavy weight.
- Flank with holes to hang tools.

PART #	LxWxH	△△△	🗑️
E8192	627x385x817mm	35.0kg	1

5 TRAY TOOL CHESTS

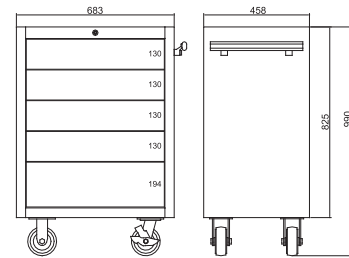

- 4 – Drawers, 578x422x130mm
- 1 – Drawers, 578x422x194mm

- 5 drawers
- Made of cold-rolled steel plate; easy to pull and push.
- Casters bearing heavy weight.
- Satisfy the needs of special industry.

PART #	LxWxH	△△△	🗑️
E8161	683x457x825mm	65.0kg	1

5 TRAY TOOL CHESTS

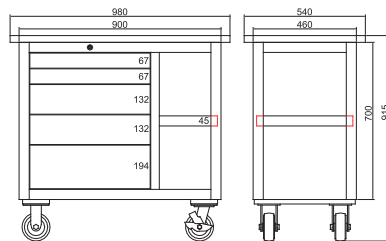

- 2 – Drawers, 515x412x67mm
- 2 – Drawers, 515x412x132mm
- 1 – Drawers, 515x412x194mm

- 5 drawers
- Made of cold-rolled steel plate; easy to pull and push.
- Casters bearing heavy weight.
- Flank with holes to hang tools.

PART #	LxWxH	△△△	🗑️
E8190	900x460x700mm	71.5kg	1

8 TRAY TOOL CHESTS

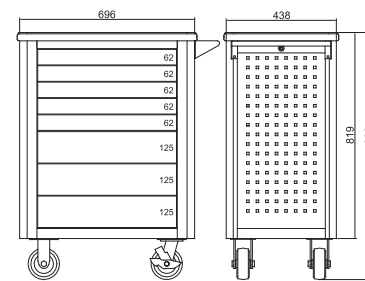

- 5 – Drawers, 531x397x62mm
- 3 – Drawers, 531x397x125mm

- 8 drawers
- Made of cold-rolled steel plate; easy to pull and push.
- Casters bearing heavy weight.
- Flank with holes to hang tools.

PART #	LxWxH	△△△	🗑️
E8195	696x438x819mm	84.5kg	1

12 TRAY TOOL CHESTS

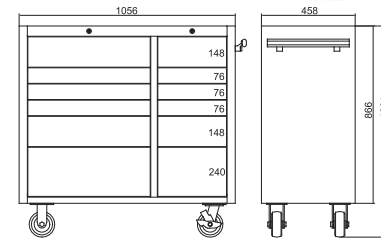

- 3 – Drawers, 578x423x76mm
- 2 – Drawers, 578x423x148mm
- 1 – Drawers, 578x423x240mm
- 3 – Drawers, 316x423x76mm
- 2 – Drawers, 316x423x148mm
- 1 – Drawers, 316x423x240mm

- 12 drawers
- Made of cold-rolled steel plate; easy to pull and push.
- Casters bearing heavy weight.
- Satisfy the needs of special industry.

PART #	LxWxH	△△△	🗑️
E8162	1056x457x866	111.0kg	1

2 TRAY TOOLS CHESTS

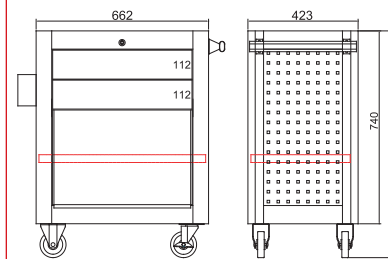

- 2 – Drawers, 515x368x112mm
- 1 – Closet, 525x381x363mm

- Made of cold-rolled steel plate
- Casters bear heavy weight

PART #	LxWxH	△△△	🗑️
E8191	662x423x740mm	68.0kg	1

HAND TRUCK



- Equipped with folding hand.
- Reasonable design, made of high quality materials, and can be widely used in various places of simple handling.

PART #	LxWxH	△△△	🗑️
E8186	905x600mm	250.0Kg	1

WORK TABLE SUPPORT

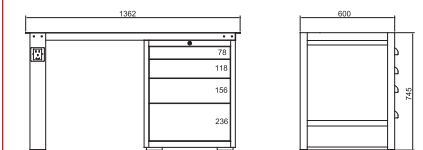

- firmed workbench frame can support 1000kg, and mounting holes are reserved on it.
- Can be sold alone

PART #	SIZE	LxWxH	△△△	🗑️
E8210A	work table with 4 drawers	1500x750x800mm	1000Kg	1
E8211A	work table with 4 drawers	1800x750x800mm	1000Kg	1
E8212A	work table with 4 drawers	2100x750x800mm	1000Kg	1
E8221A	only work table	1500x750x800mm	1000Kg	1
E8222A	only work table	1800x750x800mm	1000Kg	1
E8223A	only work table	2100x750x800mm	1000Kg	1
E8224A	wall-hung cabinet	1500x750x800mm	1000Kg	1
E8225A	wall-hung cabinet	1800x750x800mm	1000Kg	1
E8226A	wall-hung cabinet	2100x750x800mm	1000Kg	1

WORK TABLE

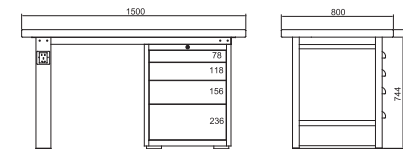
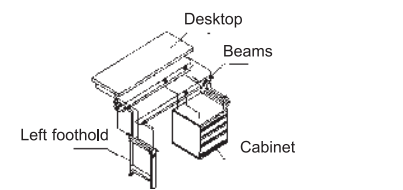

- 4 Drawers
- 1 – Drawers 450x450x80mm
- 1 – Drawers 450x450x120mm
- 1 – Drawers 450x450x160mm
- 1 – Drawers 450x450x240mm

PART #	LxWxH	Bearing	🗑️
E8201	1500x750x800mm	1000Kg	1
E8202	1800x750x800mm	1000Kg	1
E8203	2100x750x800mm	1000Kg	1

WORK TABLE

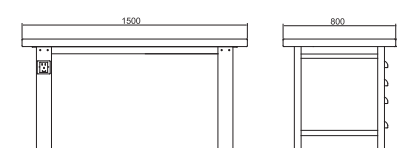
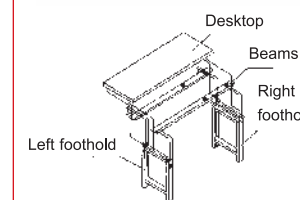

- Without chest

PART #	LxWxH	Bearing	🗑️
E8204	1500x750x800mm	1000Kg	1
E8205	1800x750x800mm	1000Kg	1
E8206	2100x750x800mm	1000Kg	1

WORK TABLE

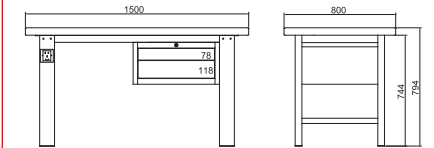
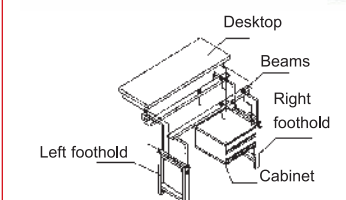

- 1 – Drawers 450x450x80mm
- 1 – Drawers 450x450x120mm

PART #	LxWxH	Bearing	🗑️
E8207	1500x750x800mm	1000Kg	1
E8208	1800x750x800mm	1000Kg	1
E8209	2100x750x800mm	1000Kg	1

2 TRAY TOOL CHESTS E8198+E8258+8257



- Made of stainless steel, easy to push.
 - 2 Caster bear heavy weight with no brake
 - The E8257 and E8259 can be used in the tool chest.
 - The E8258 can be used in the back of the chest
- Note: the chest without tools

PART #	LxWxH	△▽△	🔧
E8194	662x423x782mm	35kg	1

2TRAY TOOLS CHESTS

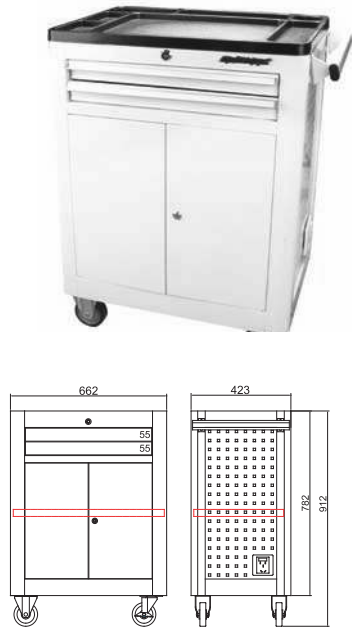

- 2-Drawers 515x377x55mm 1-closet 640x413x543mm
- Made of stainless steel, easy to push.
- Caster bear heavy weight with no brake
- The E8257 and E8259 can be used in the tool chest
- The E8258 can be used in the back of the chest

PART #	LxWxH	△▽△	🔧
E8198	662x423x782mm	37kg	1

Hanger

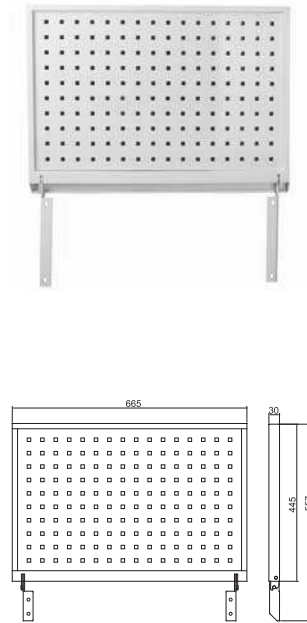

- cold rolled steel sheet
- can hang up tools and can be temporary work station
- must cooperate with the E8197 and E819

PART #	LxWxH	△▽△	🔧
E8258	660x445mm	9kg	1

1TRAY TOOLS CHESTS

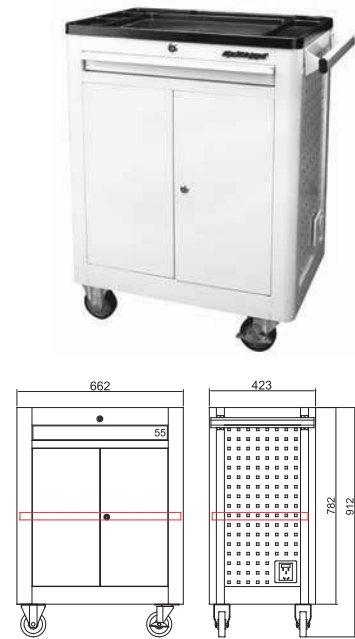

- 1-Drawers 515x377x55mm 1-closet 640x413x601mm
 - Made of stainless steel, easy to push.
 - 2 Caster bear heavy weight with no brake
 - The E8257 and E8259 can be used in the tool chest.
 - The E8258 can be used in the back of the chest
- Note: the chest without tools

PART #	LxWxH	△▽△	🔧
E8197	662x423x782mm	35kg	1

Side Cabinet

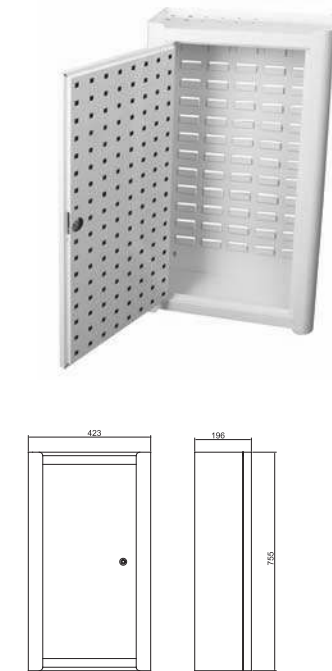

- cold-rolled steel sheet
- holes of screwdrive on the top, longer tools hang up the door, little parts can be stored in the closet.
- Cooperate with E8197 and E819

PART #	LxWxH	△▽△	🔧
E8257	420x196x755mm	12kg	1

Side Tray

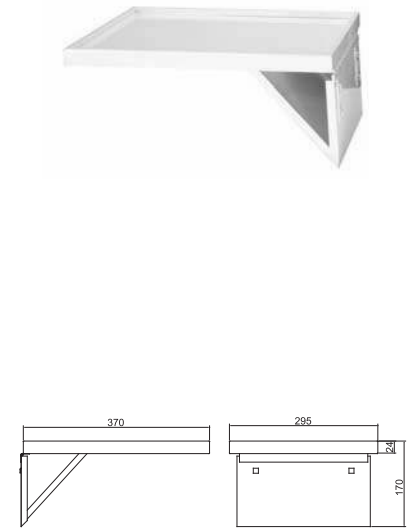

- cold-rolled steel sheet
- can be turnover
- Cooperate with E8197 and E819

PART #	LxWxH	△▽△	🔧
E8259	315x420mm	3.5kg	1

WORK TABLE PANEL

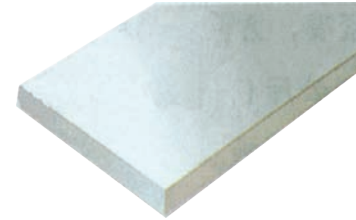

- composite materials of 1mm stainless steel, good strength, look nice, good durability, good corrosion resistance

PART #	LxWxH	△▽△	🔧
E8221B	1500x750x50mm	1000Kg	1
E8222B	1800x750x50mm	1000Kg	1
E8223B	2100x750x50mm	1000Kg	1

WORK TABLE PANEL

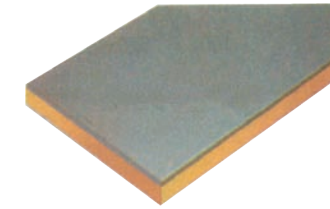

- composite materials of 8mm iron, good strength, good durability, good at impact resistance, longer service life

PART #	LxWxH	△▽△	🔧
E8221C	1500x750x50mm	1000Kg	1
E8222C	1800x750x50mm	1000Kg	1
E8223C	2100x750x50mm	1000Kg	1

MOBILE REPAIR STAND



- suit to material transport, move operation machine, assemble and maintenance.
- peg board and square hole peg board can be used in it. Square hole peg board can be installed on the wall.
- couple can be fixed on the board. Peg board incorporated with part boxes. It is flexible, law pay and high efficiency.

PART #	LxWxH	🔧
E8250	960x610x1110mm	1
E8251	960x610x1450mm	1

HANGER



- Part boxes and couple can be hung on it.
- consist of a 450mm peg board and a 450mm square hole peg board
- equipped with a ceiling panel

PART #	SIZE	LxWxH	🔧
E8221S	1500mm	1500x960mm	1
E8222S	1800mm	1800x960mm	1
E8223S	2100mm	2100x960mm	1

WORK TABLE PANE

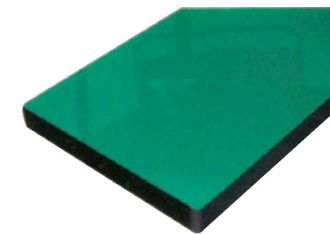

- super composite materials, high polymer material in the surface, good at weak acid and weak base resistance, wear resistance and oil resistance
- hardpressed fibreboard is used in inner to resist impact, good smoothness, good plastic edge
- unique arc design to impact

PART #	LxWxH	△▽△	🔧
E8221D	1500x750x50mm	1000Kg	1
E8222D	1800x750x50mm	1000Kg	1
E8223D	2100x750x50mm	1000Kg	1

Couple

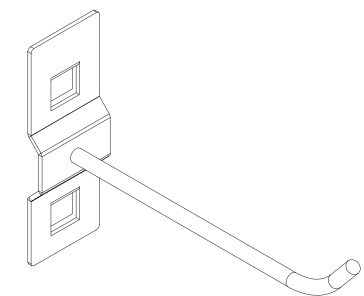

- cooperate with square hole peg board.

PART #	SIZE	LENGTH	🔧
T8901	square hole10x10mm	100.0mm	20



2

TOOL BOXES & TOOL BAGS

PORTABLE TOOL BOX



- Made of premium grade cold-rolled steel plate.

PART #	SIZE	LxWxH	Δ△	📦
E8141	19"	484x154x165mm	2.3kg	1

PORTABLE TOOL BOX



- Made of premium grade cold-rolled steel plate.

PART #	SIZE	LxWxH	Δ△	📦
E8153	20"	510x218x240mm	5.1kg	1

PORTABLE TOOL BOX



- E8133, E8134 without the Inner container.
- High quality steel.
- Easy to pull and push.
- Electrostatic spraying, nice rust protection.

PART #	SIZE	LxWxH	Δ△	📦
E8133	15"	360X150X100mm	1.15kg	1
E8134	17"	430X170X120mm	1.40kg	1
E8135	19"	470X195X180mm	1.85kg	1

PORTABLE TOOL BOX



- Made of premium grade cold-rolled steel plate.

PART #	SIZE	LxWxH	Δ△	📦
E8163	19"	484X200X165mm	2.6kg	1

CANTILEVER TOOL BOX



- 4 trays. Made of premium grade cold-rolled steel plate.

PART #	SIZE	LxWxH	Δ△	📦
E8143	15"	375X165X195mm	2.8kg	1

PORTABLE TOOL BOX



- Made of premium grade steel plate.
- With strong handle.
- Electrostatic spraying, nice rust protection.

PART #	SIZE	LxWxH	Δ△	📦
E8131	14"	340X180X140mm	1.44kg	1

PORTABLE TOOL BOX



- Made of premium grade steel plate.
- With strong handle.
- Electrostatic spraying, nice rust protection.

PART #	SIZE	LxWxH	Δ△	📦
E8142	16"	410X154X125mm	1.4kg	1

CANTILEVER TOOL BOX



- 2 trays. Made of premium grade cold-rolled steel plate.

PART #	SIZE	LxWxH	Δ△	📦
E8144	15"	375x165x150mm	1.9kg	1

CANTILEVER TOOL BOX



- 4 trays. Made of premium grade cold-rolled steel plate.

PART #	SIZE	LxWxH	ΔTΔ	📦
E8145	19"	495x200x290mm	5.5kg	1

PLASTIC TOOL BOX



- Made of reinforced plastic.
- Includes internal partitions and transparent Part box.

PART #	SIZE	LxWxH	ΔTΔ	📦
E8123	15"	370x195x185mm	1.2kg	8

HAND-AWAY TOOL BOX



- Heavy-duty handle, strong and durable
- Electrostatic spraying, nice rust protection.
- Stamped one time,



- Design of two layers, space used reasonable

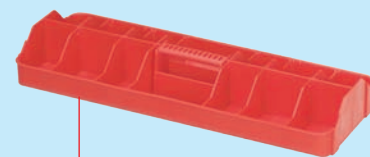

- High quality plastic injection molding, intermediate baffle is optional.

- Stamped one time
- Heavy-duty handle, strong and durable.
- Electrostatic spraying, nice rust protection.

2TRAY TOOL BOX



- 2 – Drawers, 501x189x48mm
- Made of premium grade steel plate.
- With strong handle.

PART #	LxWxH	ΔTΔ	📦
E8155	534x218x288mm	9.5kg	1

PLASTIC TOOL BOX



- Made of reinforced plastic.
- Includes internal partitions and transparent Part box.

PART #	SIZE	LxWxH	ΔTΔ	📦
E8124	17"	420x220x195mm	1.6kg	6
E8125	19"	450x245x210mm	2.1kg	4

3 TRAY TOOL BOX



- 2 – Drawers, 501x189x36mm
- 1 – Drawers, 501x189x75mm
- Made of premium grade steel plate.
- With strong handle.

PART #	LxWxH	ΔTΔ	📦
E8156	534x218x288mm	11.0kg	1

PLASTIC TOOL BOX



- Made of reinforced plastic.
- Includes internal partitions and transparent Part box.

PART #	SIZE	LxWxH	ΔTΔ	📦
E8113	13"	335x185x130mm	0.6kg	6
E8114	16"	405x260x185mm	1.1kg	4
E8115	19"	495x280x235mm	1.6kg	2

ALUMINUM CASE



special products

- Withstands fierce impact.

PART #	SIZE	LxWxH	ΔTΔ	📦
E8182	15"	384x250x260mm	3.2kg	1

TOOL BAG



- Made of Oxford cloth; water-proof and durable.
- Convenient to carry tools.

PART #	SIZE	LxWxH	📦
E8311	13"	320x220x260mm	18
E8312	16"	400x220x260mm	12
E8313	17"	430x220x260mm	12

TOOL BIB APRON



special products

- Made of Oxford cloth; water-proof and durable.
- Convenient to carry tools.

PART #	WxH	📦
E8331	590x740mm	24

ALUMINUM CASE



special products

- Reinforced and durable metal lock catch.

PART #	SIZE	LxWxH	ΔTΔ	📦
E8174	16.5" thicken	435x305x125mm	2.25kg	5

WAIST POUCH



- Made of Oxford cloth; water-proof and durable.
- Convenient to carry tools.

PART #	WxH	📦
E8321	335x260mm	24

TOOL VEST



- Made of Oxford cloth; water-proof and durable.
- Convenient to carry tools.

PART #	WxH	📦
E8341	530x690mm	30

ALUMINUM CASE



special products

- Reinforced and durable metal lock catch.

PART #	SIZE	LxWxH	ΔTΔ	📦
E8173	17" thin	438x328x105mm	2.4kg	5

WAIST POUCH



- Made of Oxford cloth; water-proof and durable.
- Convenient to carry tools.

PART #	WxH	📦
E8322	540x270mm	24

TOOL BOX



New Products

- Made of premium grade cold-rolled steel plate.

PART #	LxWxH	ΔTΔ	📦
E8105	221x129x44mm	0.46kg	1
E8106	380x140x52mm	0.91kg	1
E8107	440x190x52mm	1.25kg	1

PLASTIC LOGISTIC CASE



- Made of Premium-grade PP, more durable.

PART #	LxWxH	Stacked Bearing	Slacked Bearing	Weight
E8274	600x400x150mm	30kg	150kg	4
E8275	600x400x215mm	30kg	150kg	4

PLASTIC TOOL BOX



- Made of Premium-grade PP.
- Water-proof, and UV-proof; resistant to oil and chemicals.

PART #	SIZE	LxWxH	Weight
E8411	#1	140x75x27mm	12
E8412	#2	167x126x62mm	12
E8413	#3	205x140x45mm	12
E8414	#4	234x168x62mm	6
E8415	#5	300x200x62mm	6

BACK HANGING PARTS BOX



- Convenient combination, save space.
- Widely used in workshop, warehouse, storage.
- Can be customized in different color.

PART #	LxWxH	Bear	Weight
E8281	110x105x52mm	2kg	6
E8282	140x105x75mm	2kg	6
E8283	190x105x75mm	3kg	6
E8284	220x140x125mm	6kg	6
E8285	270x140x125mm	8kg	6

ENDURA®
A Textron Company

ENDURA®
A Textron Company

ENDURA®
A Textron Company



ENDURA®
A Textron Company

3

TOOLS SETS

TOOLS SETS

75PC.MACHINE REPAIR SET



- 1-Plastic-coated Handled Adjustable Wrench 8"
- 7-Comb. Wrench 11,12,13,14,15,17,19mm
- 12-1/4" Dr. Socket 4,4.5,5.5,6,7,8,9,10,11,12,13mm
- 1-1/4" Dr. Quick-Release Ratchet
- 1-1/2" Dr. Quick-Release Ratchet
- 1-1/4" Dr. Bit Adapter
- 9-1/2" Dr. Socket 10,12,13,14,15,16,17,19,22mm
- 1-1/2" Dr. Extension Bar 5"
- 1-1/2" Dr. Spark Plug Socket 16mm
- 2-Long Nose Plier 6",Lineman's Plier 7"
- 1-Straight Jaw Locking Plier 10"
- 1-Groove Joint Plier 10"
- 2-Screwdriver Slotted 6x38,6x100mm
- 2-Screwdriver Phillips #2x38,#2x100mm
- 1-Spinner Handle
- 3-1/4" Dr. 25mm Bits Slotted 4,5,5.5,6.5mm
- 3-1/4" Dr. 25mm Bits Phillips #1,#2,#3
- 6-1/4" Dr. 25mm Bits Hex 2,2.5,3,4,5,6mm
- 6-1/4" Dr. 25mm Bits Torx T10,T15,T20,T25,T27,T30
- 2-Mini Hacksaw 6",Knife 18mm
- 1-Ball Pein Hammer 12oz
- 8-Hex Key 1.5,2,2.5,3,4,5,5.5,6mm
- 1-Tape Measure 3mx16mm
- 2-9pcs Feeler Gauge Set, Brush
- Case Size: 420 x 315 x 80mm
- Suitable for auto, factory, mining industry installation, repair and maintenance.

PART #	CONTENTS	△△	📦
E1313	75PCS	6.7kg	4

48PC.AUTO REPAIR TOOL SET



- 8-Comb. Wrench10,11,12,13,14,15,17,19mm
- 8-1/2" Dr. Socket 10,11,12,13,14,15,17,19mm
- 8-1/2" Dr. Socket 20,21,22,23,24,27,30,32mm
- 1-1/2" Dr. Quick-Release Ratchet
- 2-1/2" Dr. Extension Bars",10"
- 1-1/2" Dr. Sliding T-bar
- 1-1/2" Dr. 3-way Joint
- 1-1/2" Dr. Universal Joint
- 9-Hex. Key1.5,2,2.5,3,4,5,6,8,10mm
- 3-Screwdriver Slotted3x100,6x38,6x100mm
- 4-Screwdriver Phillips3x100,6x38,6x100,8x200mm
- 1-Combination Plier7"
- 1-Groove Joint Plier 10"
- Case Size: 420 x 315 x 80mm
- Suitable for auto, factory, mining industry installation, repair and maintenance.

PART #	CONTENTS	△△	📦
E1318	48PCS	6.3kg	6

13PC.AUTO REPAIR TOOL SET



- 2-Screwdriver Slotted 6x38,6x100mm
- 2-Screwdriver Phillips #2x38,#2x100
- 1-Heavy Duty European-type Adjustable Wrench 8"
- 1-Long Nose Plier 6"
- 1-Diagonal Plier 6"
- 1-Vinyl Electrical Insulating Tape
- 1-Tyre Wrench
- 1-1/2" Dr. 6pt. Multi-socket 17x19mm
- 1-Charging Wire
- 1-Tire Gauges
- 1-Nylon Fillet

- Box Size: 420 x 315 x 80mm
- Indispensable tool assy for auto repair.

PART #	CONTENTS	△△	📦
E1211	13PCS	3.4kg	6

49PC.TELE-COMMUNICATION TOOL SET



- 1-Heavy Duty Adjustable Wrench 6"
- 1-Digital Detecting Screwdriver
- 2-Screwdriver Slotted 6x38,5x100mm
- 2-Screwdriver Phillips 5x100,6x100mm
- 3-Long Nose Plier6", Diagonal Nose Plier6", German-type Lineman's Plier6"
- 1-Claw Hammer 8oz
- 1-Mini Nylon Handled Hacksaw 6"
- 1-Rubber&Plastic Bits Handle
- 1-Mini LED Flashlight
- 5-Long Hex Key 2,3,4,5,6mm
- 3-Mini Screwdriver Slotted 2.0x75,3.0x100,4.0x150mm
- 3-Mini Screwdriver Philips PH00x75,PH0x100,PH1x150mm
- 3-1/4" Dr. 25L Bits Slotted 4,5,5.5,6.5mm
- 3-1/4" Dr. 25L Bits Phillips #1,#2,#3
- 6-1/4" Dr. 25L Bits Hex 2,2.5,3,4,5,6mm
- 6-1/4" Dr. 25L Bits Torx T10,T15,T20,T25,T27,T30

- Box Size: 420 x 315 x 80mm
- Suitable for plant and mining industry, auto, household's daily repair and maintenance.

PART #	CONTENTS	△△	📦
E1421	49PCS	3.9kg	6

50PC.TELE-COMMUNICATION TOOL SET



- 1-Adjustable Wrench 6"
- 2-1/4" Dr. Bit Adapter, Spinner Handle
- 12-1/4" Dr. Socket 4,4.5,5.5,6,7,8,9,10,11,12,13mm
- 2-Long Nose Plier 6",Diagonal Plier 6"
- 2-Screwdriver Slotted 6x38,6x100mm
- 2-Screwdriver Phillips #2x38,#2x100mm
- 2-Digital Detecting Screwdriver, Digital Multi-meter
- 3-Mini Screwdriver Slotted 2.0x75,3.0x100,4.0x150mm
- 3-Mini Screwdriver Phillips PH00x75,PH0x100,PH1x150mm
- 3-1/4" Dr. 25mm Bits Slotted 4,5,5.5,6.5mm
- 3-1/4" Dr. 25mm Bits Phillips #1,#2,#3
- 4-1/4" Dr. 25mm Bits Hex 3,4,5,6mm
- 3-1/4" Dr. 25mm Bits Torx T10,T15,T20
- 2-Art Designing Knife 18mm, Tape Measure 3mx16mm
- 1-Long Life Soldering Iron 30W
- 2-Solder Absorber, Brush
- 2-Wire Stripper 8", Vinyl Electrical Insulating Tape
- 1-Stainless Fine Point Tweezer

- Box Size: 420 x 315 x 80mm
- Suitable for plant, mining industry, household, etc.

PART #	CONTENTS	△△	📦
E1411	50PCS	3.0kg	6

52PC.MACHINE REPAIR SET



- 5-C Steel Comb. Wrench 8,10,12,13,14mm
- 6-1/4" Dr.6PT Socket 5,6,7,8,9,10mm
- 8-3/8" Dr. Socket 10,11,12,13,14,15,17,19mm
- 1-3/8" Dr. Quick-Release Ratchet
- 1-3/8" Dr. Extension Bar 6"
- 1-3/8" Dr. Adapter 10mmx6.3mm
- 1-3/8" Dr. Spark Plug Socket 21mm
- 1-Long Nose Plier 6"
- 1-Screwdriver Slotted 6x100mm
- 1-Screwdriver Phillips #2x100mm
- 1-Multi-Ratchet Screwdriver
- 1-Mini Screwdriver Slotted 1.4x40mm
- 1-Mini Screwdriver Phillips PH00x40mm
- 3-1/4" Dr. 25mm Bits Slotted 4,5,5.5,6.5mm
- 3-1/4" Dr. 25mm Bits Phillips #1,#2,#3
- 3-1/4" Dr. 25mm Bits Hex 4,5,6mm
- 4-1/4" Dr. 25mm Bits Torx T10,T15,T20,T25
- 1-Utility Knife
- 8-8pcs Long Point Hex Key 1.5,2,2.5,3,4,5,6,8mm
- 1-Bits Holder

- Box Size: 380 x 260 x 80mm
- Suitable for plant and mining industry, equipment installment and maintenance.

PART #	CONTENTS	△△	📦
E1314	52PCS	2.9kg	6

70PC.MACHINE REPAIR SET



- 8-8pcs Hex Key 1.5,2,2.5,3,4,5,5.5,6mm
- 1-Heavy Duty Adjustable Wrench 8"
- 5-Comb. Wrench 8,10,12,13,14mm
- 9-1/4" Dr. 6PT Socket 4,5,6,7,8,9,10,11,12mm
- 1-1/4" Dr. Bits Adapter
- 8-3/8" Dr. 6PT Socket 10,11,13,14,15,16,17,19mm
- 1-3/8" Dr. Quick-Release Ratchet
- 1-3/8" Dr. Extension Bar 3"
- 1-3/8" Dr. Adapter 10MMx6.3MM
- 1-3/8" Dr. Spark Plug Socket 16mm
- 2-Lineman's Plier 7",Groove Joint Plier 10"
- 4-Screwdriver Slotted 3x100,5x100,6x38,6x150mm
- 4-Screwdriver Phillips #0x100,#1x100,#2x38,#2x150mm
- 3-1/4" Dr. 25mm Bits Slotted 4,5,5.5,6.5mm
- 3-1/4" Dr. 25mm Bits Phillips #1,#2,#3
- 6-1/4" Dr. 25mm Bits Hex 2,2.5,3,4,5,6mm
- 3-1/4" Dr. 25mm Bits Torx T10,T15,T20
- 1-1/4" Dr. Spinner Handle
- 1-Vinyl Electrical Tape
- 1-Art Designing Knife 18mm
- 1-9pcs Feeler Gauge Set
- 1-Digital Detecting Screwdriver 190mm
- 1-Engineering Hammer 300g
- 1-Tape Measure 5mx19mm
- 2-Flat File 8", Round File 8"

- Box Size: 420 x 315 x 80mm
- Suitable for plant and mining industry, equipment installment and maintenance.

PART #	CONTENTS	△△	📦
E1315	70PCS	5.1kg	6

63PC.AUTO REPAIR TOOL SET



- 1-8pcs Hex Key 1.5,2,2.5,3,4,5,6,8mm
- 1-Adjustable Wrench 8"
- 7-1/4" Dr. 6PT. Socket 4,4.5,5.5,6,7,8mm
- 5-1/4" Dr. 6PT. Socket 9,10,11,12,13mm
- 1-1/4" Dr. Quick-Release Ratchet
- 1-1/4" Dr. Bit Adapter
- 10-3/8" Dr. 6PT. Socket 10,11,12,13,14,15,16,17,18,19
- 1-3/8" Dr. Quick-Release Ratchet
- 1-3/8" Dr. Extension Bar 3"
- 1-3/8" Dr. Universal Joint
- 1-3/8" Dr. Adapter 10mmx6.3mm
- 2-3/8" Dr. Spark Plug Socket16mm,21mm
- 1-Slip Joint Plier 6"
- 1-Screwdriver Slotted 6x100mm
- 1-Screwdriver Phillips #2x100mm
- 1-Spinner Handle
- 3-1/4" Dr. 25mm Bits Slotted 4,5,5.5,6.5mm
- 3-1/4" Dr. 25mm Bits Phillips #1,#2,#3
- 6-1/4" Dr. 25mm Bits Hex 2,2.5,3,4,5,6mm
- 6-1/4" Dr. 25mm Bits Torx T10,T15,T20,T25,T27,T30
- 1-9pcs Feeler Gauge Set
- 1-Tire Gauge
- 6-Combination Wrench10,12,13,14,17,19mm
- 1-Brush

- Box Size: 380 x 260 x 80mm
- Suitable for plant and mining industry, auto, household, etc.

PART #	CONTENTS	△△	📦
E1221	63PCS	3.8kg	6

58PC. TELE-COMMUNICATION TOOL SET



- 1-Adjustable Wrench 8"
- 12-1/4" Dr. 6PT. Socket 4,4.5,5.5,6,7,8,9,10,11,12,13mm
- 1-1/4" Quick-release Ratchet
- 2-Long Nose Plier 6",Lineman's Plier 6"
- 3-Screwdriver Slotted 3x200,6x38,6x100mm
- 3-Screwdriver Phillips #0x200,#2x38,#2x100mm
- 1-Bits Handle
- 2-Digital Detecting Screwdriver
- 3-Mini Screwdriver Slotted 2.0x75,3.0x100,4.0x150mm
- 3-Mini Screwdriver Phillips PH00x75,PH0x100,PH1x150
- 3-1/4" Dr. 25L Bits Slotted 4,5,5.5,6.5mm
- 3-1/4" Dr. 25L Bits Phillips #1,#2,#3
- 3-1/4" Dr. 25L Bits Hex 4,5,5.5,6.5mm
- 3-1/4" Dr. 25L Bits Torx T10,T15,T20
- 1-Electrical Knife 80mm
- 1-Mini Nylon Hacksaw6"
- 5-Hex Key 2,3,4,5,6mm
- 1-Tape Measure 3mx16mm
- 1-Digital Multi-meter
- 1-Alloy Flashlight 2AA
- 1-Long Life Soldering Iron 30W
- 1-Art Designing Knife18mm
- 1-Solder Wire17g
- 1-Multi-purpose Wire Stripper
- 1-Vinyl Electrical Insulating Tape

- Box Size: 420 x 315 x 80mm
- Suitable for plant, mining industry, household, etc.

PART #	CONTENTS	△△	📦
E1412	58PCS	3.9kg	6

19PC.TELE-COMMUNICATION TOOL SET



- 1-Adjustable Wrench 6"
- 1-Mini Long Nose Plier 4.5"
- 1-Mini Diagonal Plier 4.5"
- 2-Screwdriver Slotted 5x75mm,6x100mm
- 2-Screwdriver Phillips #1x100mm,#2x150mm
- 1-Cr-V Japanese-type Long Nose Plier 6"
- 1-Cr-V Japanese-type Diagonal Plier 6"
- 1-Claw Hammer 8oz
- 1-1/4" Dr. Spinner Handle
- 1-Plastic Flashlight 2AA
- 8-1/4" Dr. 6PT. Socket 6,7,8,9,10,11,12,13
- 1-Art Designing Knife 9mm
- 1-Tape Measure 3mx16mm
- 1-Digital Multi-meter
- 1-Long Life Soldering Iron 30W
- 1-Stainless Fine Point Tweezer
- 2-Vinyl Electrical Insulating Tape, Solder Wire 17g
- 1-Aluminium Flashlight 1AA

- Box Size: 380 x 260 x 80mm
- Suitable for plant, mining industry, household, etc.

PART #	CONTENTS	△△	📦
E1416	19PCS	2.1kg	6

24PC.TELE-COMMUNICATION TOOL SET



- 1-Adjustable Wrench6"
- 1-Digital Detecting Screwdriver
- 2-Screwdriver Slotted 5x100mm,6x150mm
- 2-Screwdriver Phillips #1x100mm,#2x150mm
- 1-Cr-V Japanese-type Long Nose Plier 6"
- 1-Cr-V Japanese-type Diagonal Plier 6"
- 1-Claw Hammer 8oz
- 1-1/4" Dr. Spinner Handle
- 1-Plastic Flashlight 2AA
- 8-1/4" Dr. 6PT. Socket 6,7,8,9,10,11,12,13
- 1-Art Designing Knife 9mm
- 1-Tape Measure 3mx16mm
- 1-Digital Multi-meter
- 1-Long Life Soldering Iron 30W
- 1-Plastic Solder Absorber

- Box Size: 380 x 260 x 80mm
- Suitable for plant, mining industry, household, etc.

PART #	CONTENTS	△△	📦
E1419	24PCS	2.4kg	6

Gift: Soldering Iron Bracket

136PC.AUTO REPAIR TOOL SET



- 9—Long Ball Point Hex Key 1.5,2,2.5,3,4,5,5.5,6,8,10mm
- 1—Adjustable Wrench 8"
- 10—Comb. Wrench 8,9,10,11,12,13,14,15,17,19mm
- 11—1/4" Dr. 6PT.Socket 4,4.5,5,6,7,8,9,10,11,12,13mm
- 4—1/4" Dr. 6PT. Deep Socket 8,9,10,12mm
- 1—1/4" Dr. Quick-Release Ratchet
- 1—1/4" Dr. Extension Bar 2"
- 1—1/4" Dr. Universal Joint
- 1—1/4" Dr. Bit Adapter
- 11—3/8" Dr. 6PT. Socket 9,10,11,12,13,14,15,16,17,18,19mm
- 4—3/8" Dr. 6PT. Deep Socket 13,14,15,17mm
- 1—3/8" Dr. Quick-Release Ratchet
- 2—3/8" Dr. Extension Bar 3",6"
- 1—3/8" Dr. Universal Joint
- 1—3/8" Dr. Bit Adapter 10MMx6.3MM
- 2—3/8" Dr. Spark Plug Socket 16,21mm
- 7—1/2" Dr. 6PT. Socket 20,21,22,24,27,30,32mm
- 5—1/2" Dr. 6PT. Deep Socket 13,14,15,17,19mm
- 6—1/2" Dr. 12PT. Socket 10,12,14,15,17,19mm
- 1—1/2" Dr. Quick-Release Ratchet
- 2—1/2" Dr. Extension Bar 5",10"
- 1—1/2" Dr. Sliding Bar
- 1—1/2" Dr. Universal Joint
- 1—1/2" Dr. Adapter 12.5MMx10MM
- 1—Long Nose Plier 6"
- 1—Diagonal Plier 8"
- 1—Slip Joint Plier 8"
- 1—Groove Joint Locking Plier 10"
- 1—Go Through Screwdriver Slotted 6x150mm
- 1—Go Through Screwdriver Phillips #2x150mm
- 2—Screwdriver Slotted 6x150mm,3x150mm
- 2—Screwdriver Phillips #0x100,#2x100mm
- 1—1/4" Dr. Spinner Handle
- 3—1/4" Dr. 25mm Bits Slotted 4,5,5.5,6,5mm
- 3—1/4" Dr. 25mm Bits Phillips #1,#2,#3
- 6—1/4" Dr. 25mm Bits Hex 2,2.5,3,4,5,6mm
- 6—1/4" Dr. 25mm Bits Torx T10,T15,T20,T25,T27,T30
- 1—Finishing Hammer With Wooden Handle 35mm
- 1—Flat File 8"
- 1—Magnetic Pick Up
- 1—Aluminium Flashlight 2AA
- 1—Auto Voltage Tester
- 1—Knife 18mm
- 1—20pcs Feeler Gauge Set
- 1—1/2" Dr. L-Type Wrench
- 1—Tire Gauge
- 8—L-Type Torx Wrenches T6,T7,T8,T9,T10,T15,T20,T25
- 6—Punch Set

- Box Size:505x360x90mm
- Suitable for auto, factory, mining industry installation, repair and maintenance.

PART #	CONTENTS	ΔTΔ	📦
E1223	136PCS	14.0kg	2

120PC.AUTO REPAIR TOOL SET



- 9—9PC. Long Ball Point Hex Key Set
- 1—Heavy Duty Adjustable Wrench8"
- 7—Comb. Wrench 8,9,10,11,12,13,14,17,18,19mm
- 10—1/4" Dr. 6PT. Socket (Metric) 4,5,6,7,8,9,10,11,12,13mm
- 4—1/4" Dr. 6PT. Deep Socket (Metric) 8,9,10,12mm
- 1—1/4" Dr. 6PT. Quick-release Ratchet
- 1—1/4" Dr. Extension Bar 2"
- 1—1/4" Dr. Universal Joint
- 1—1/4" Dr. Bit Adapter
- 11—3/8" Dr.6PT. Socket 9,10,11,12,13,14,15,16,17,18,19
- 4—3/8" Dr.6PT. Deep Socket 13,14,15,17mm
- 8—3/8" Dr.6PT. Socket Star E8,E10,E11,E12,E14,E16,E18,E20
- 1—3/8" Dr. Bit Socket TORX T-20
- 1—3/8" Dr. Bit Socket TORX T-25
- 1—3/8" Dr. Bit Socket TORX T-30
- 1—3/8" Dr. Bit Socket TORX T-40
- 1—3/8" Dr. Bit Socket TORX T-45
- 1—3/8" Dr. Bit Socket TORX T-50
- 1—3/8" Dr. Bit Socket TORX T-55
- 4—3/8" Dr. Bit Socket HEX 3,4,5,6mm
- 2—3/8" Dr. Bit Socket Phillips PH1,PH2
- 2—3/8" Dr. Bit Socket Slotted 5,5.5,6,5mm
- 1—3/8" Dr. Quick-release Ratchet Wrench
- 1—3/8" Dr. Extension Bar 10"
- 1—3/8" Dr. Extension Bar 3"
- 1—3/8"Dr. Universal Joint
- 2—3/8" Dr. Spark Plug Socket 16,21mm
- 7—1/2" Dr. 6PT. Socket 20,21,22,24,27,30,32mm
- 1—1/2" Dr. Quick-release Ratchet
- 2—1/2"Dr. Extension Bar 5",10"
- 1—1/2" Dr. Universal Joint
- 1—Cr-V Japanese-type Long Nose Plier 6"
- 1—Cr-V Japanese-type Diagonal Plier 6"
- 1—Cr-V Lineman's Plier 7"
- 1—Rubber &Plastic Handled Screwdriver Slotted 6x125mm
- 1—Rubber &Plastic Handled Screwdriver Phillips #2x125mm
- 1—1/4" Dr. Bit Handle
- 3—1/4"Dr. 25L Bits Slotted 4,5,5,6,5mm
- 3—1/4"Dr. 25L Bits Phillips #1,#2,#3
- 6—1/4"Dr. 25L Bits Hex 2,2.5,3,4,5,6mm
- 6—1/4" Dr. Bits Torx T-10,T-15,T-20,T-25,T-27,T-30
- 1—1/4" Dr. Bits Holder
- 1—20PC. Feeler Gauge Set

- Box Size:505x360x90mm
- Suitable for auto, factory, mining industry installation, repair and maintenance.

PART #	CONTENTS	ΔTΔ	📦
E1226	120PCS	13.0kg	2

127PC.MACHINE RAPAIR SET



- 9—9PC. Long Ball Point Hex Key Set
- 1—Heavy Duty Adjustable Wrench8"
- 7—Comb. Wrench 11,12,13,14,15,17,19mm
- 12—1/4" Dr. 6PT. Socket (Metric) 4,4.5,5.5,5.5,6,7,8,9,10,11,12,13mm
- 4—1/4" Dr. 6PT. Deep Socket (Metric) 8,9,10,12mm
- 1—1/4" Dr. Quick-release Ratchet
- 1—1/4" Dr.Adapter 10mmx6.3mm
- 3—1/4"Dr. 25L Bits Slotted 4,5,5,6,5mm
- 3—1/4"Dr. 25L Bits Phillips #1,#2,#3
- 6—1/4"Dr. 25L Bits Hex 2,2.5,3,4,5,6mm
- 6—1/4" Dr. Bits Torx T-10,T-15,T-20,T-25,T-27,T-30
- 1—1/4" Dr. Bit Handle
- 1—1/2" Dr.Quick-Release Ratchet
- 16—1/2" Dr.Socket 10,12,13,14,15,16,17,19,20,21,22,23,24,27,30,32mm
- 5—1/2" Deep Socket 13,14,15,17,19mm
- 1—1/2" Dr.Extension Bar 5"
- 1—1/2" Dr.Adapter 12.5x10mm
- 1—1/2" Dr.Adapter 10x6.3mm
- 1—1/2" Dr.Spark plug socket 16mm
- 5—5/16" Dr.30L Slotted bits 5,5,6,5,8,10,12mm
- 3—5/16" Dr.30L Phillips Bits #1,#2,#3
- 4—5/16" Dr.30L Hex Bits 5,6,8,10mm
- 1—5/16" Dr.Impact Handle
- 1—Cr-V Japanese-type Long Nose Plier 6"
- 1—Cr-V Japanese-type Diagonal Plier 6"
- 1—Curved Jawlocking Pliers 10"
- 1—Pipe Wrench 12"
- 4—Screwdrivers Slotted 3x125,6x100,Phillips #0x125,#2x100
- 2—Go Through Screwdrivers Slotted 6x150, Phillips #2x150
- 1—Digital Voltage Tester
- 2—1/2"Dr. Extension Bar 5",10"
- 1—Tape Measure 5mx19mm
- 1—Stainless Steel Ruler 300mmx25mm
- 1—Hacksaw 12"
- 3—Hacksaw Blades 18 teeth, 24 teeth, 32 teeth
- 1—Brush
- 1—20PC. Feeler Gauge Set
- 1—Knife 18mm
- 1—Claw Hammer 300g
- 1—Aluminium Flashlight 2AA
- 2—Flat File 8", Three-Square File 8"
- 10—10PC File Set

- Box Size: 505x360x90mm
- Suitable for plant and mining industry, equipment's installment and maintenance.

PART #	CONTENTS	ΔTΔ	📦
E1316	127PCS	13.5kg	2

9PC.HOME SET



- 1-Adjustable wrench 8"
- 1-Lineman's Plier 7"
- 2-Screwdriver Slotted 5x75, 6x100mm
- 2-Screwdriver Phillips #1x75, #2x100mm
- 1-Digital Screwdriver 140mm
- 1-Knife 18mm
- 1-Tape Measure 3mx16mm

- Box size: 250 x 185 x 52mm
- Maintenance tool kit suitable for plant, mining, industry, household, etc.

PART #	CONTENTS	ΔTΔ	📦
E1106	9PCS	1.7kg	6

13PC.HOME SET



- 1-Adjustable wrench 8"
- 1-Long nose plier 6"
- 1-Screwdriver Slotted 6x100mm
- 1-Screwdriver Phillips #2x100mm
- 1-Digital Screwdriver 140mm
- 1-Mini Screwdriver Slotted 2.0x75mm
- 1-Mini Screwdriver Phillips #00x75mm
- 1-Knife 9mm
- 1-Stainless Steel Scissor 7"
- 1-Claw Hammer 8oz
- 1-Tape Measure 3mx16mm
- 1-Vinyl Electrical Tape
- 1-Aluminium Flashlight 1AA

- Box size: 280 x 205 x 52mm
- Maintenance tool kit suitable for plant, mining, industry, household, etc.

PART #	CONTENTS	ΔTΔ	📦
E1107	13PCS	2.0kg	6

14PC.HOME SET



- 1—6PC. Mini Screwdriver Set
- 1—Adjustable Wrench 6"
- 1—Long Nose Plier 6"
- 1—Slip Joint Plier 6"
- 2—Screwdriver Slotted6x38,6x100mm
- 2—Screwdriver Phillips #2x38,#2x100mm
- 1—Knife18mm
- 1—Mini Hacksaw 6"
- 1—Tape Measure 3mx16mm
- 1—Claw Hammer 8oz
- 1—Stainless Steel Scissor 9"
- 1—Vinyl Electrical Insulating Tape

- Box Size:380x260x80mm
- Maintenance tool kit suitable for plant, mining industry, household, etc.

PART #	CONTENTS	ΔTΔ	📦
E1112	14PCS	2.5kg	6

19PC.HOME SET



- 1- Adjustable Wrench 6"
- 5 -Combination Wrench10,12,13,14,15mm
- 1—Long Nose Plier 6"
- 1—Slip Joint Plier 6"
- 1—Screwdriver Slotted 6x100mm
- 1—Screwdriver Phillips #2x100mm
- 4-Mini Screwdriver Slotted 1.4x40,2.0x40,2.4x40,3.0x40mm
- 2-Mini Screwdriver Phillips Ph00x40mm,Ph0x40mm
- 1—Tape Measure 3mx16mm
- 1—Zinc Alloy Steel Utility Knife
- 1—Claw Hammer 8oz16oz

- Box Size: 380 x 260 x 80mm
- Maintenance tool kit suitable for plant, mining industry, household, etc.

PART #	CONTENTS	ΔTΔ	📦
E1111	19PCS	2.8kg	6

20PC.HOME SET



- 1—8pcs Hex Key 1.5,2,2.5,3,4,5,5.5,6mm
- 1—Adjustable Wrench 8"
- 2—Long Nose Plier 6",Lineman's Plier 6"
- 2—Screwdriver Slotted 5x100,6x150mm
- 2—Screwdriver Phillips #1x100,#2x150mm
- 2—Mini Screwdriver 3.0x100mm,Phillips PH0x100mm
- 1—Claw Hammer 16oz
- 1—Tape Measure 3mx16mm
- 1—Art Designing Knife 18mm
- 1—Stainless Steel Scissor 7"
- 1—Detecting Screwdriver 190mm
- 1—Long Life Soldering Iron 30W
- 1—Vinyl Electrical Tape
- 1—Solder Wire 17g
- 1—Aluminium Flashlight 1AA
- 1—Multi-Hardware Box
- Box size: 380 x 260 x 80mm
- Maintenance tool kit suitable for plant, mining industry, household, etc.

PART #	CONTENTS	ΔTΔ	📦
E1105	20PCS	3.1kg	6

18PC.HOME SET



- 1—4pcs Mini Screwdriver Set
- 1—Adjustable Wrench 6"
- 2—Long Nose Plier 6", Lineman's Plier 6"
- 2—Screwdriver Slotted 6x38,6x150mm
- 2—Screwdriver Phillips #2x38,#2x150mm
- 1—Knife18mm
- 2—Mini Hacksaw 6", Mini Saw 6"
- 1—Claw Hammer 8oz
- 1—Tape Measure 3mx16mm
- 1—Stainless Steel Scissor 7"
- 1—Vinyl Electrical Insulating Tape
- 1—Detecting Screwdriver 140mm
- 1—Aluminium Flashlight 1AA
- 1—Multi-Hardware Box
- Box Size: 380 x 260 x 80mm
- Maintenance tool kit suitable for plant, mining industry, household, etc.

PART #	CONTENTS	ΔTΔ	📦
E1104	18PCS	2.6kg	6

15PC.HOME SET



- 4 – 4PCS Mini Screwdriver
- 1 – Adjustable Wrench 8"
- 1 – Long Nose Plier 6"
- 1 – Screwdriver Slotted 6 x 100mm
- 1 – Screwdriver Phillips# 2 x 100mm
- 1 – Digital Detecting Screwdriver
- 3 – Cutting Knife,Mini Hacksaw 6", Claw Hammer 8oz
- 3 – Stainless Steel Scissor,Tape Measure 3m x 16mm, Vinyl Electrical Tape

- Box Size: 380 x 260 x 80mm
- Suitable for household

PART #	CONTENTS	△▽	📦
E1001	15PCS	1.7kg	6

51PC.TELE-COMMUNICATION TOOL SET



- 4 – 4pcs Mini Screwdriver
- 1 – Digital Detecting Screwdriver
- 1 – Adjustable Wrench 8"
- 2 – Lineman's Plier 6",Groove Joint Plier 8"
- 1 – Multi-Function Wire Stripper
- 2 – Screwdriver Slotted 3x200,6x100mm
- 2 – Screwdriver Phillips #0x200,#2x100mm
- 1 – 1/4" Dr. Spinner Handle
- 1 – 1/4" Dr. Bit Adapter
- 3 – 1/4" Dr. 25L Bits Slotted 4,5,5,6,5mm
- 3 – 1/4" Dr. 25L Bits Phillips #1,#2,#3
- 6 – 1/4" Dr. 25L Bits Hex 2,2,5,3,4,5,6mm
- 6 – 1/4" Dr. 25L Bits Torx T10,T15,T20,T25,T27,T30
- 3 – Electrical Knife 80mm,Vinyl Electrical Tape
- 2 – Solder Wire 17g,Stainless Fine Point Tweezer
- 7 – Hex Key 1.5,2,3,4,5,6,8mm
- 1 – Tape Measure 3m x 16mm
- 1 – Digital Multi-meter
- 1 – Claw Hammer 8oz
- 2 – Mini Hacksaw 6", Mini Saw 6"
- 1 – Long Life Soldering Iron 30W
- 1 – Aluminium Flashlight 1AA

- Box Size: 420 x 315 x 80mm
- Suitable for plant, mining industry, household, etc.

PART #	CONTENTS	△▽	📦
E1414	51PCS	4.0kg	6

78PC.AUTO REPAIR TOOL SET



- 11 – Comb. Wrench 7, 8, 9, 10,11,12,13,14,15,17,18,19mm
- 12-1/4" Dr. 6PT. Socket 4,4.5,5.6,7,8,9,10,11,12,13mm
- 10 – 1/2" Dr. Socket 8, 9, 10, 11,12,13,14,15,17,19mm
- 8 – 1/2" Dr. Socket 20,21,22,23,24,27,30,32mm
- 1-1/4" Professional Quick-Release Ratchet
- 2-1/4" Extension Bar 2", 4"
- 1-1/4" Sliding T-Bar
- 1-1/4" Universal Joint
- 1-1/4" Dr. Bit Adapter
- 1 – 1/4" Dr. Spinner Handle
- 1-1/2" Professional Quick-Release Ratchet
- 2-1/2" Extension Bar 5",10"
- 1 – 1/2" Dr. Sliding T-bar
- 1 – 1/2"Dr. Spark Plug Socket 21mm
- 1-1/2" Universal Joint
- 7 – Hex. Key 2,3,4,5,6,8,10mm
- 3-1/4" Dr. Slotted Bits 4, 5, 5.5, 6.5mm
- 3-1/4" Dr. Phillips Bits #1,#2,#3
- 6-1/4" Dr. Hex. Bits 2,2.5,3,4,5,6mm
- 6-1/4" Dr. Torx Bits T10, T15, T20,T25,T27,T30

- Case Size: 420 x 315 x 80mm
- Suitable for auto, factory, mining industry installation, repair and maintenance.

PART #	CONTENTS	△▽	📦
E1319	78PCS	6.1kg	6

52PC.TELE-COMMUNICATION TOOL SET



- 1 – Adjustable Wrench 6"
- 12 – 1/4" Dr. 6PT Socket 4, 4.5, 5.5, 6, 7, 8, 9, 10, 11, 12, 13mm
- 1 – 1/4" Dr. Bit Adapter
- 1 – Long Nose Plier 6"
- 1 – Diagonal Plier 6"
- 1 – Groove Joint Plier 10"
- 1 – 1/4" Dr. Spinner Handle
- 2 – Screwdriver Slotted 6x38,6x100mm
- 2 – Screwdriver Phillips #2x38,#2x100mm
- 1 – Digital Detecting Screwdriver
- 3 – Multi Screwdriver Slotted 2.0x75,3.0x100,4.0x150mm
- 3 – Multi Screwdriver Phillips PH00x75,PH00x100,PH1x150
- 3 – 1/4" Dr. 25L Bits Slotted 4,5,5,6,5mm
- 3 – 1/4" Dr. 25L Bits Phillips #1,#2,#3
- 4 – 1/4" Dr. 25L Bits Hex 3,4,5,6mm
- 3 – 1/4" Dr. 25L Bits Torx T10,T15,T20
- 1 – Art Designing Knife 18mm
- 1 – Tape Measure 3m x 16mm
- 1 – Digital Multi-meter
- 1 – Vinyl Electrical Insulating Tape
- 1 – Long Life Soldering Iron 30W
- 1 – Claw Hammer 8oz
- 1 – Solder Wire 17g
- 2 – Mini Hacksaw 6", Mini Saw 6"
- 1 – Stainless Fine Point Tweezer

- Box Size:420 x 315 x 80mm
- Suitable for plant, mining industry, household, etc.

PART #	CONTENTS	△▽	📦
E1413	52PCS	3.9kg	6

34PC.TELE-COMMUNICATION TOOL SET



- 1 – Heavy Duty Adjustable Wrench 6"
- 1 – Cr-V Mini Long Nose Plier 4.5"
- 1 – Cr-V Mini Diagonal Plier 4.5"
- 11 – 1/4" Dr. 6PT. Socket 4,5,5.6,7,8,9,10,11,12,13mm
- 1 – 1/4" Quick-release Ratchet Wrench
- 2 – Rubber & Plastic Handled Screwdriver Slotted 3x75mm,5x100mm
- 2 – Rubber & Plastic Handled Screwdriver Phillips 3x75mm,5x100mm
- 6 – Extra Long Flat Head Hex Key 2,2.5,3,4,5,6mm
- 1 – Long Life Soldering Iron 30W
- 1 – Soldering Iron Bracket
- 1 – Plastic Manual Solder Absorber
- 1 – Wire Stripper
- 1 – Stainless Fine Point Tweezer
- 1 – Stainless Curved Tips Tweezer
- 1 – Digital Detecting Screwdriver
- 1 – Vinyl Electrical Insulating Tape
- 1 – Solder Wire 17g
- 1 – Digital Multi-meter

- Box Size: 380 x 260 x 80mm
- Suitable for plant, mining industry, household, etc.

PART #	CONTENTS	△▽	📦
E1420	34PCS	2.8kg	6

68PC.M&E REPAIR SET



- 4-Mini Screwdriver Set
- 2-1/4" Dr. Bits Adapter, Spinner Handle
- 2-Multi Function Wire Stripper, Digital Detecting Screwdriver
- 3-1/4" Dr. Slotted Bits 4,5,6mm
- 3-1/4" Dr. Phillips Bits #1,#2,#3
- 6-1/4" Dr. Hex. Bits 2,2.5,3,4,5,6mm
- 6-1/4" Dr. Torx Bits T10, T15, T20,T25,T27,T30
- 3-Electrical Knife 80mm, Mini Hacksaw 6", Claw Hammer 8oz
- 8 – Hex. Key 1.5,2,3,4,5,6,8,10mm
- 3-Digital Multi-meter, Aluminium Flashlight 1AA, Soldering Iron 30W
- 3-Tweezer, Electrical Tape 18mmx9m, Mini Hacksaw Blade
- 3-Solder Wire 17g, Heavy Duty Adjustable Wrench 8", Soldering Iron Support
- 12-3/8" Dr. 6PT. Socket 8,9,10,11,12,13,14,15,16,17,18,19mm
- 1-3/8"Quick-release Ratchet
- 3-Cr-V Long Nose Plier, Diagonal Plier 6", Lineman's Plier 6"
- 3-Groove Joint Plier 10", Aluminium Knife 18x100mm, Tape Measure 5mx19mm
- 2-Screwdriver Slotted 3.0x200mm, 6x100mm
- 2-Screwdriver Phillips #0x200mm, #2x100mm

PART #	CONTENTS	△▽	📦
E1321	68PCS	7.5kg	6

120PC.AUTO REPAIR TOOL SET



- 10-Combination Wrench 8,10,12,13,14,15,16,17,18,19mm
- 8-1/4" Dr.6PT Socket 6,7,8,9,10,11,12,13mm
- 6-1/4" Dr.6PT Deep Socket 6,7,8,10,12,13mm
- 2-1/4" Dr.Extension Bar 2",4"
- 1-1/4" Dr. Spinner Handle
- 1-1/4" Dr. Sliding T-bar
- 9-3/8" Dr.6PT Socket 10,11,12,13,14,15,16,17,18mm
- 6-3/8" Dr.6PT Deep Socket 8,10,12,13,14,15mm
- 6-3/8" Dr. Star Socket E8,E10,E11,E12,E14,E16
- 1-3/8" Dr. Sliding T-bar
- 1-3/8" Dr.3-way Joint
- 1-3/8" Dr.Adapter 3/8"x1/4"
- 2-3/8" Dr.Extension Bar 6",10"
- 13-1/2" Dr.6PT Socket 14,15,16,17,18,19,20,21,22,24,27,30,32mm
- 4-1/2" Dr.6PT Deep Socket 17,18,19,22mm
- 2-1/2" Dr. Extension Bar 5",10"
- 2-1/2" Dr. Spark Plug Socket 16,21mm
- 1-1/2" Dr. L-type Wrench 250mm
- 2-1/2" Dr. Adapter 1/2"x3/8", 1/2"x5/16"
- 3-1/4",3/8",1/2" Dr. Professional Ratchet
- 3-1/4",3/8",1/2" Dr. Universal Joint
- 4-1/2" Dr.6PT Impact Socket 17,19,21,22mm
- 3-1/4" Dr. Bit Socket Slotted 4,0,5,5.6,5mm
- 2-1/4" Dr. Bit Socket Phillips PH1,PH2
- 4-1/4" Dr. Bit Socket Hex 3,4,5,6mm
- 7-1/4" Dr. Bit Socket Torx T8,T10,T15,T20,T25,T30,T40
- 2-5/16" Dr.70L Bits Slotted 5,5.6,5mm
- 3-5/16" Dr.70L Bits Phillips PH1,PH2,PH3
- 2-5/16" Dr.70L Bits Spline M6,M8
- 4-5/16" Dr.70L Bits Hex 6,7,8,10mm
- 5-5/16" Dr.70L Bits Torx T20,T30,T40,T45,T50

- Box size: 505x355x95mm
- Suitable for auto, factory, mining industry installation, repair and maintenance.

PART #	CONTENTS	📦
E1209	120PCS	2

150PC VEHICLE SET



- 5-Full Polished Double Box End Geartech wrench 8x10,12x13,14x15,16x18,17x19mm
- 10-Combination Wrench 8,10,12,13,14,15,16,17,18,19mm
- 8-1/4" Dr.6PT Socket 6,7,8,9,10,11,12,13mm
- 5-1/4" Dr.6PT Deep Socket 6,7,8,12,13mm
- 2-1/4" Dr.Extension Bar 2",4"
- 1-1/4" Dr. Spinner Handle
- 1-1/4" Dr. Bit Adapter
- 11-3/8" Dr.6PT Socket 8,9,10,11,12,13,14,15,16,17,18mm
- 6-3/8" Dr.6PT Deep Socket 8,10,12,13,14,15mm
- 6-3/8" Dr. Star Socket E8,E10,E11,E12,E14,E16
- 1-3/8" Dr. Sliding T-bar
- 1-3/8" Dr.3-way Joint
- 1-3/8" Dr. Adapter 3/8"x1/4"
- 2-3/8" Dr.Extension Bar 6",10"
- 13-1/2" Dr.6PT Socket 14,15,16,17,18,19,20,21,22,24,27,30,32mm
- 4-1/2" Dr.6PT Deep Socket 17,18,19,22mm
- 2-1/2" Dr. Extension Bar 5",10"
- 2-1/2" Dr. Spark Plug Socket 16,21mm
- 1-1/2" Dr. L-type Wrench 250mm
- 1-1/2" Dr. Adapter 1/2"x3/8"
- 3-1/4",3/8",1/2" Dr. Professional Ratchet
- 3-1/4",3/8",1/2" Dr. Universal Joint
- 3-3/8" Dr. Bit Socket Slotted 5,5.6,5,8mm
- 3-3/8" Dr. Bit Socket Phillips PH1,PH2,PH3
- 5-3/8" Dr. Bit Socket Hex 4,5,6,7,8mm
- 8-3/8" Dr. Bit Socket Torx T20,T25,T27,T30,T40,T45,T50,T55
- 4-1/2" Dr.100L Bit Socket Spline M6,M8,M10,M12
- 5-1/2" Dr.100L Bit Socket Hex 5,6,7,8,10mm
- 4-1/2" Dr.100L Bit Socket Torx T27,T30,T40,T45
- 3-Lineman's plier 6", Long Nose Plier 6", Diagonal Plier 6"
- 2-Go Through Screwdriver Slotted 6x100mm,Phillips #2x100mm
- 9-Torx Hex Key Set T10,T15,T20,T25,T27,T30,T40,T45,T50
- 9-Long Ball Point Hex Key 1.5,2,2.5,3,4,5,6,8,10mm
- 6-1/4" Dr.25L Bits Slotted 4,5,5.6,5mm, Phillips #1,#2,#3

- Box size: 505x355x95mm
- Suitable for auto, factory, mining industry installation, repair and maintenance.

PART #	CONTENTS	📦
E1210	150PCS	2

9PC.ELECTRICAL TOOL SET



- 3-mini Wobbler screwdriver T4x40 T6x40 T7x40mm
- 1-mini Carbon Steel long nose Plier 4.5"
- 1-mini Diagonal Plier 4.5"
- 1-mini Screwdriver Slotted 2.0x40
- 2-Mini Screwdriver Phillips PH0x40,PH00x40mm
- 1-C clips

- Box size:211x139x23mm
- suitable for electrical equipment maintenance

PART #	CONTENTS	△▽	📦
E1151	9PCS	0.4kg	6

10PC.ELECTRICAL TOOL SET



- 3-mini Wobbler screwdriver T4x40 T6x40 T7x40mm
- 1-mini Screwdriver Slotted 2.0x40
- 1-Mini Screwdriver Phillips PH0x40,PH00x40mm
- 1-special-purpose plastics to open phone
- 1-special-purpose plastics to close phone
- 1-C clips

- Box size:211x139x23mm
- suitable for electrical equipment maintenance

PART #	CONTENTS	△▽	📦
E1152	10PCS	0.26kg	6

120+2PCS AUTO REPAIR TOOLS SET



- 11-Combination Wrench 8,9,10,11,12,13,14,16,17,18,19mm
- 9-Long Hex Key 1.1,1.5,2,3,4,5,6,8,10mm
- 11-1/4" Dr.6PT Socket 4,5,5.6,7,8,9,10,11,12,13mm
- 4-1/4" Dr.6PT Deep Socket 8,10,12,13mm
- 1-1/4" Dr.Extension Bar 2"
- 1-1/4" Dr.Bit Adater
- 1-1/4" Dr. Spinner Handle
- 11-3/8" Dr.6PT Socket 8,9,10,12,13,14,15,16,17,18,19mm
- 4-3/8" Dr.6PT Deep Socket 13,14,15,17mm
- 6-3/8" Dr. Star Socket E8,E10,E11,E14,E16,E20
- 2-3/8" Dr.Spark Plug Socket 16,21mm
- 1-3/8" Dr.3-way Joint
- 2-3/8" Dr.Extension Bar 3",6"
- 3-1/4",3/8",1/2" Dr. Professional Ratchet
- 3-1/4",3/8",1/2" Dr. Universal Joint
- 2-3/8" Dr. Adapter 3/8"x1/4",3/8"x1/2"
- 2-3/8" Dr. Bit Socket Slotted 5,5.6,5mm
- 2-3/8" Dr. Bit Socket Phillips PH1,PH3
- 2-3/8" Dr. Bit Socket Poz PZ1,P23
- 4-3/8" Dr. Bit Socket Hex 4,5,6,8mm
- 6-3/8" Dr. Bit Socket Torx T20,T30,T40,T45,T50,T55
- 1-2way Oil Filter Wrench
- 1-Nut Socket
- 1-Gear Box Socket M16
- 1-Bit Socket T52
- 1-6PT Socket H17
- 1-Auto Voltage Tester
- 2-Go Through Screwdriver Slotted 6x100mm,Phillips #2x100mm
- 3-1/4" Dr.25L Bits Slotted 4,5,6,5mm
- 2-1/4" Dr.25L Bits Phillips PH1,PH3
- 2-1/4" Dr.25L Bits Poz PZ1, P23
- 4-1/4" Dr.25L Bits Hex 3,4,5,6mm
- 7-1/4" Dr.25L Bits Torx T10,T12,T20,T25,T27,T30,T40

- Box size: 505x355x95mm
- Suitable for auto, factory, mining industry installation, repair and maintenance.

PART #	CONTENTS	📦
E1208	120+2PCS	2

9 PC. Portable Tool Set



- 1-adjustable Wrench 8"
- 1-Carbon Steel Lineman's Plier
- 1-Carbon Steel long nose Plier 6"
- 1-Rubber & Plastic Handled Screwdriver Slotted 6x100mm
- 1-Rubber & Plastic Handled Screwdriver Slotted PH2x100mm
- 1-Detecting Screwdriver 140mm
- 1-Tape Measure 3m x 16mm
- 1-LED Flashlight
- 1-8ps. Metric Folding Hex Key Set

- Box size:290x190x55mm

PART #	CONTENTS	📦
E1137	9PCS	1

7 PC. PORTABLE TOOL SET



- 1 - Heavy Duty Adjustable Wrench 8"
- 1 - Lineman's Plier 7"
- 1 - Screwdriver Slotted 6x100mm
- 1 - Screwdriver Phillips #2x100mm
- 1 - Detecting Screwdriver 140mm
- 1 - Knife 18mm
- 1 - Tape Measure 3mx16mm

• Box Size:265x170x55mm

PART #	CONTENTS	Δ	Δ	☞
E1121	7PCS	1.2kg		18

8PC.PORTABLE TOOL SET



- 1 - Adjustable Wrench 8"
- 1 - Slip Joint Plier 6"
- 1 - Long Nose Plier 6"
- 1 - Screwdriver Slotted 6x150mm
- 1 - Screwdriver Phillips #2x150mm
- 1 - Detecting Screwdriver 140mm
- 1 - Claw Hammer 8oz
- 1 - Tape Measure 3mx16mm

• Box Size:290x190x55mm

PART #	CONTENTS	Δ	Δ	☞
E1122	8PCS	1.5kg		12

9PC.PORTABLE TOOL SET



- 1 - Adjustable Wrench 8"
- 1 - Lineman's Plier 7"
- 2 - Screwdriver Slotted 5x100mm,6x150mm
- 2 - Screwdriver Phillips 1x100mm,2x150mm
- 1 - Detecting Screwdriver 140mm
- 1 - Knife 18mm
- 1 - Tape Measure 3mx16mm

• Box Size:290x190x55mm

PART #	CONTENTS	Δ	Δ	☞
E1123	9PCS	1.3kg		18

15PC.ELECTRONIC TOOL



- 2 - Mini Long Nose Plier 4.5", Mini Diagonal Plier 4.5"
- 2 - Screwdriver Slotted 6x100mm, Phillips #2x100mm
- 1 - Detecting Screwdriver 140MM
- 2 - Mini Rubber & Plastic Screwdriver 2.0x75mm, PH00x75mm
- 1 - Long Life Soldering Iron 30W
- 1 - Stainless Steel Scissor 7"
- 1 - Aluminium Flashlight 1AA
- 1 - Stainless Fine Point Tweezer
- 1 - Vinyl Electrical Insulating Tape
- 1 - Knife 9mm
- 1 - Tape Measure 3mx16mm
- 1 - Solder Wire 17g

• Box Size:290x190x55mm

PART #	CONTENTS	Δ	Δ	☞
E1126	15PCS	1.1kg		18

19PC.ELECTRONIC TOOL



- 1 - Adjustable Wrench 6"
- 1 - Mini Long Nose Plier 4.5"
- 1 - Mini Diagonal Plier 4.5"
- 2 - Screwdriver Slotted 5x75,6x100mm
- 2 - Screwdriver Phillips #1x75,#2x100mm
- 1 - Digital Detecting Screwdriver
- 1 - Screwdriver Slotted 2.0x75mm
- 1 - Screwdriver Phillips PH00x75mm
- 2 - Knife 9mm,Tape Measure 3mx16mm
- 1 - Aluminium Flashlight 1AA
- 1 - Long Life Soldering Iron 30W
- 2 - Solder Absorber, Solder Wire 17g
- 1 - Stainless Fine Point Tweezer
- 1 - Vinyl Electrical Insulating Tape

• Box Size:290x190x55mm

PART #	CONTENTS	Δ	Δ	☞
E1127	19PCS	1.3kg		18

7 PCS. PORTABLE TOOL SET



- 1 - Heavy Duty Europe Style Adjustable Wrench 8"
- 1 - Carbon Steel Long Nose Plier 6"
- 1 - Detecting Screwdriver 140mm
- 1 - Plastic Handle Utility Knife 18mm
- 1 - Tape Measure 3m x16mm
- 1 - Black Vinyl Electrical Tape 18mmx9m
- 1 - 2 pcs. Screwdriver Set

• Box Size:290x190x55mm

PART #	CONTENTS	☞
E1133	7PCS	1

8 PCS. PORTABLE TOOL SET



- 1 - Heavy Duty Europe Style Adjustable Wrench 8"
- 1 - Carbon Steel Linesman's Plier 7"
- 1 - Detecting Screwdriver 140mm
- 1 - Plastic Handle Utility Knife 18mm
- 1 - Curved claw Hammer Steel Handle 8oz
- 1 - Tape Measure 3m x16mm
- 1 - Black Vinyl Electrical Tape 18mmx9m
- 1 - 2 pcs. Screwdriver Set

• Box Size:290x190x55mm

PART #	CONTENTS	☞
E1134	8PCS	1

10 PCS. PORTABLE TOOL SET



- 1 - 8 pcs. Metric Folding Hex Key Set
- 1 - Luxury Plastic Enveloped Adjustable Wrench 8"
- 1 - Cr-V Steel German Style Long Nose Plier 6"
- 1 - Cr-V Steel German Style Linesman's Plier 7"
- 1 - TPR Handle Screwdriver Slotted 6x100mm Cr-Mo blade
- 1 - TPR Handle Screwdriver Phillips #2x100mm Cr-Mo blade
- 1 - Detecting Screwdriver 140mm
- 1 - 12 in 1 Knife
- 1 - Tape Measure 3m x16mm
- 1 - Aluminum LED Flashlight

• Box Size:290x190x55mm

PART #	CONTENTS	☞
E1136	10PCS	1

42PC.AUTO REPAIR TOOL



- 7 - 3/8" Dr. Socket 6,7,8,9,10,11,12mm
- 7 - 3/8" Dr. Socket 13,14,15,16,17,18,19mm
- 1 - 3/8" Dr. Quick-Release Ratchet
- 2 - 3/8" Dr. Extension Bar 3",6"
- 1 - 3/8" Dr. Universal Joint
- 1 - 3/8" Dr. Adapter 10mmx6.3mm
- 1 - 3/8" Dr. Spark Plug Socket 16mm
- 2 - Spinner Handle, Slip Joint plier 6"
- 2 - 1/4" DR. Bit Adapter, Vinyl Electrical Insulating Tape
- 3 - 1/4" Dr. 25mm Bits Slotted 4,5,5,6,5mm
- 3 - 1/4" Dr. 25mm Bits Phillips #1,#2,#3
- 6 - 1/4" Dr. 25mm Bits Hex 2,2,5,3,4,5,6mm
- 6 - 1/4" Dr. 25mm Bits Torx T10,T15,T20,T25,T27,T30

• Box Size:310x210x55mm

- Tools suitable for plant and mining industry, auto, household, etc.

PART #	CONTENTS	Δ	Δ	☞
E1128	42PCS	2.1kg		12

60PC.AUTO REPAIR TOOL



- 1 - 8pcs Hex Key 1.5,2.2,5,3,4,5,5,6mm
- 1 - Heavy Duty Adjustable Wrench 6"
- 6 - 1/4" Dr. 6PT. Socket 8,9,10,11,12,13mm
- 6 - 1/4" Dr. 6PT. Socket 4,4,5,5,5,6,7mm
- 1 - 1/4" Dr. Quick-Release Ratchet
- 1 - 1/4" Dr. Bit Adapter
- 5 - 3/8" Dr. 6PT. Socket 10,11,12,13,14mm
- 5 - 3/8" Dr. 6PT. Socket 15,16,17,18,19mm
- 1 - 3/8" Dr. Quick-Release Ratchet
- 2 - 3/8" Dr. Extension Bar 3",3/8" DR. Universal Joint
- 1 - 3/8" Dr. Adapter 10mmx6.3mm
- 2 - 3/8" Dr. Spark Plug Socket 16,21mm
- 2 - Slip Joint Plier 6", Brush
- 2 - Screwdriver Slotted 6x100mm, Phillips #2x100mm
- 1 - 1/4" Dr. Spinner Handle
- 3 - 1/4" Dr. 25mm Bits Slotted 4,5,5,6,5mm
- 3 - 1/4" Dr. 25mm Bits Phillips #1,#2,#3
- 6 - 1/4" Dr. 25mm Bits Hex 2,2,5,3,4,5,6mm
- 6 - 1/4" Dr. 25mm Bits Torx T10,T15,T20,T25,T27,T30
- 3 - Open End Wrench 8x9,12x13,16x17mm
- 2 - 9pcs Feeler Gauge Set, Tire Guage

• Box Size:310x210x55mm

- Tools suitable for plant and mining industry, auto, household, etc.

PART #	CONTENTS	Δ	Δ	☞
E1129	60PCS	2.9kg		6

10PC.PORTABLE TOOL SET



- 1 - Heavy Duty Adjustable Wrench 6"
- 1 - Lineman's Plier 6"
- 2 - Screwdriver Slotted 5x75mm,6x100mm
- 2 - Screwdriver Phillips #1x75mm,#2x100mm
- 1 - Detecting Screwdriver 190mm
- 1 - Knife 18mm
- 1 - Stainless Steel Scissor 8"
- 1 - Tape Measure 3mx16mm

• Box Size:265x170x55mm

PART #	CONTENTS	Δ	Δ	☞
E1124	10PCS	1.1kg		18

12PC.PORTABLE TOOL SET



- 1 - Adjustable Wrench 8"
- 1 - Long Nose Plier 6"
- 1 - Screwdriver Slotted 6x100mm
- 1 - Screwdriver Phillips #2x100mm
- 1 - Detecting Screwdriver 140MM
- 1 - Mini Screwdriver Slotted 2.0x75mm
- 1 - Mini Screwdriver PH00x75mm
- 1 - Knife 9mm
- 1 - Stainless Steel Scissor 7"
- 1 - Claw Hammer 8oz
- 1 - Tape Measure 3mx16mm
- 1 - Vinyl Electrical Insulating Tape

• Box Size:290x190x55mm

PART #	CONTENTS	Δ	Δ	☞
E1125	12PCS	1.5kg		12

19PC.GEARTECH WRENCH TOOL KIT



- 15-Full Polished Geartech Wrench 6,7,8,9,10,11,12,13,14,15,16,17,18,19,21mm
- 3-Quick Release Adapter 3/8",1/2",3/4"
- 1-Bits Adapter 1/4"x3/8"

PART #	CONTENTS	☞
E1923	19PCS	1

34PC. 3/8" DR.SOCKET TOOL KIT



- 18-3/8" DR. 6PT. Socket 6,7,8,9,10,11,12,13,14,15,16,17,18,19,20,21,22,24mm
- 9-3/8" DR. 6PT. Metric Deep Socket 8,10,11,12,13,14,15,17,19mm
- 2-3/8" DR. Spark Plug Socket 16,21mm
- 2-3/8" DR. Entention Bar 3",10"
- 1-3/8" DR. Professional Ratchet Wrench
- 1-3/8" DR. Universal Joint
- 1-3/8" DR. Three Way Adapter

PART #	CONTENTS	☞
E1925	34PCS	1

20PC. 1/2" DR.SOCKET TOOL KIT



- 12-1/2" DR. 6PT. Socket 10,11,12,13,14,15,16,17,18,19,22,24mm
- 3-1/2" DR. 6PT. Deep Socket 13,17,19mm
- 1-1/2" DR. Professional Ratchet Wrench
- 1-1/2" DR. Entention Bar 10"
- 1-3/8" DR. Three Way Adapter
- 1-1/2" DR. Spark Plug Socket 16mm
- 1-1/2" DR. Universal Joint

PART #	CONTENTS	☞
E1926	20PCS	1

24PC. 1/2" DR.SOCKET TOOL KIT



- 18-1/2" DR. 6PT. Socket 10,11,12,13,14,15,16,17,18,19,20,21,22,23,24,27,30,32mm
- 1-1/2" DR. Professional Ratchet Wrench
- 2-1/2" DR. Entention Bar 5",10"
- 1-3/8" DR. Three Way Adapter
- 1-1/2" DR. Universal Joint
- 1-1/2" DR. Flexible Handle 10"

PART #	CONTENTS	☞
E1927	24PCS	1

32PC. 1/2" DR.SOCKET TOOL KIT



- 21-1/2" DR. 6PT. Socket 8,9,10,11,12,13,14,15,16,17,18,19,20,21,22,23,24,27,30,32,34mm
- 5-1/2" DR. 12PT. Socket 10,12,14,17,19mm
- 1-1/2" DR. Professional Ratchet Wrench
- 2-1/2" DR. Entention Bar 5",10"
- 1-1/2" DR. Speed Brace
- 1-1/2" DR. L Type Wrench 250mm
- 1-1/2" DR. Universal Joint

PART #	CONTENTS	☞
E1928	32PCS	1

59PC. 1/4" Dr. SOCKET TOOL KIT



13-1/4" Dr. 6PT. Socket 4,4.5,5.5,6,7,8,9,10,11,12,13,14mm
 11-1/4" Dr. 6PT. Deep Socket 4,5,5.5,6,7,8,9,10,11,12,13mm
 1-1/4" Professional Quick-Release Ratchet
 2-1/4" Extension Bar 2", 4"
 1-1/4" Sliding T-Bar
 1-1/4" Universal Joint
 1-1/4" Dr. Bit Adapter
 1-1/4" Dr. Spinner Handle
 3-1/4" Dr. Bit Sockets Slotted 4.0, 5.5, 6.5mm
 2-1/4" Dr. Bit Sockets Phillips PH1,PH2
 4-1/4" Dr. Bit Sockets Hex 3,4,5,6mm
 7-1/4" Dr. Bit Sockets Torx T8,T10,T15,T20,T25,T30,T40
 3-1/4" Dr. 25L Slotted Bits 4, 5.5, 6.5mm
 3-1/4" Dr. 25L Phillips Bits #1,#2,#3
 3-1/4" Dr. 25L Hex. Bits 2,2.5,3mm
 3-1/4" Dr. 25L Torx Bits T10, T15, T20

PART #	CONTENTS	
E1911	59PCS	1

41PC. 3/8" Dr. SOCKET TOOL KIT



16-3/8" Dr. 6PT. Socket 8,9,10,11,12,13,14,15,16,17,18,19,20,21,22,24mm
 8-3/8" Dr. 6PT. Deep Socket 10,11,12,13,14,15,17,19cm
 8-3/8" Dr. 6PT. Star Socket E8,E10,E11,E12,E14,E16,E18,E20
 1-3/8" Professional Quick-Release Ratchet
 4-3/8" Extension Bar 3",6", Universal Joint, 3-Way Joint
 2-3/8"Dr. Spark Plug Socket 16mm, 21mm
 2-3/8" Socket Adapter 10mmx6.3mm, 10mmx12.5mm
 1-3/8" Dr. Adapter

PART #	CONTENTS	
E1912	41PCS	1

28PC. 1/2" Dr. SOCKET TOOL KIT



20-1/2" Dr. 6PT. Socket 8,9,10,11,12,13,14,15,16,17,18,19,20,21,22,23,24,27,30,32mm
 4-1/2" Dr. 12PT. Socket 14,15,17,19mm
 1-1/2" Professional Quick-Release Ratchet
 1-1/2" Extension Bar 10"
 2-1/2" Universal Joint, 3-Way Joint

PART #	CONTENTS	
E1913	28PCS	1

14PC. COMBINATION WRENCH TOOL KIT



2-Geartech Wrench Set 13,14mm
 12-Combination Wrench 8,9,10,11,12,13,14,15,16,17,18,19mm

PART #	CONTENTS	
E1914	14PCS	1

26PC. DOUBLE OPEN WRENCH & HEX KEY TOOL KIT



9-9pc. L-Type Torx Wrench
 9-9pc. Hex. Key Set
 8-Open End Wrench 6x7,8x10,10x12,11x13,12x14,22x24,24x27,30x32mm

PART #	CONTENTS	
E1915	26PCS	1

4PC. PLIERS TOOL KIT



2-Adjustable Wrench 8",10"
 1-Curved Jawlocking Pliers 10"
 1-Long Noselocking Pliers W/Cutting Edge 6.5"

PART #	CONTENTS	
E1916	4PCS	1

4PC. PLIERS TOOL KIT



4-Snap Ring Pliers External 7"(straight & Curved Jaw) , Snap Ring Pliers Internal 7"(straight & Curved Jaw)

PART #	CONTENTS	
E1917	4PCS	1

4PC. PLIERS TOOL KIT



2-Long Nose Pliers 6", Diagonal Pliers 6"
 2-Plastic Cutting Pliers 6", Lineman's Pliers 8"

PART #	CONTENTS	
E1918	4PCS	1

13PC. SCREWDRIVER KIT



6-6pcs. Mini Screwdriver Set
 3-Screwdriver Slotted 3x75, 5x75, 6x100 mm
 3-Screwdriver Phillips 3x75, 5x75, 6x100 mm
 1-Go Through Screws Phillips PH3x150mm

PART #	CONTENTS	
E1919	13PCS	1

10PC. DOUBLE BOX END WRENCH TOOL KIT



5-Double Box End Wrench 6x7, 8x10, 10x12, 11x13, 12x14mm
 5-Double Box End Wrench 17x19, 14x17, 9x21, 21x23, 24x27mm

PART #	CONTENTS	
E1920	10PCS	1

8PC. FILE TOOL KIT



3-Flat File & Half-Round File & Round File, 4x160mm
 5-Flat file & Half Round File & Round File, Three Square File, Square File, 8"

PART #	CONTENTS	
E1921	8PCS	1

36PC. IMPACT TOOL KIT



2-10mm Impact Socket Adapter 3/8" x 1/4", 3/8" x 1/2"
 1-10mm Impact Extension Bar 75mm
 1-12.5mm Impact Extension Bar 150mm
 2-12.5mm Impact Adapter 1/2" x 3/4", 1/2" x 3/8"
 1- Impact Universal Joint 1/2" x 1/2"
 13-10mm Impact Sockets 7,8,9,10,11,12,13,14,15,16,17,18,19mm
 16-12.5mm Impact Sockets 10,11,12,13,14,15,16,17,18,19,21,22,24,27,30,32mm

PART #	CONTENTS	
E1922	36PCS	1

246PC TOOL TRAY SET



E1911 59Pcs 6.3mm Socket Set
 E1912 41Pcs 10mm Socket Set
 E1913 28Pcs 12.5mm Socket Set
 E1914 14Pcs Combination Wrench Set
 E1915 26Pcs Open end Wrench & Hex Set
 E1916 4Pcs Adjustable Wrench & Locking Pliers
 E1917 4pcs Snap Ring Pliers Set
 E1918 4Pcs Pliers Set
 E1919 13Pcs Screwdriver Set
 E1920 10Pcs Double Box end wrench set
 E1921 8Pcs Files Set
 E1922 36Pcs 10mm & 12.5mm impact socket set

• Without the 7 drawers tool cart

PART #	CONTENTS	
E1816	246PCS	1



4

Hand Sockets & Driver Tools

86PC. 1/4" + 1/2" Dr. SOCKET SET



- 13 - 1/4" Dr. 6PT. Socket 4,4.5,5.5,6,7,8,9,10,11,12,13,14mm
- 8 - 1/4" Dr. 6PT. Deep Socket 6,7,8,9,10,11,12,13mm
- 1 - 1/4" Dr. Quick-release Ratchet Wrench
- 2 - 1/4" Dr. Extension Bar 2", 4"
- 1 - 1/4" Dr. Sliding T-bar
- 1 - 1/4" Dr. Spinner Handle
- 1 - 1/4" Dr. Universal Joint
- 1 - 1/4" Dr. Bit Adapter
- 14 - 1/2" Dr. 6PT. Deep Socket 10,13,14,16,17,19,20,21,22,23,24,27,30,32mm
- 4 - 1/2" Dr. 6PT. Deep Socket 14, 15, 17, 19mm
- 1 - 1/2" Dr. Quick-release Ratchet Wrench
- 2 - 1/2" Dr. Extension Bar 5", 10"
- 1 - 1/2" Dr. Universal Joint
- 2 - 1/2" Dr. Spark Plug Socket 16mm, 21mm
- 7 - 1/4" Dr. Bit Socket TORX T-8, T-10, T-15, T-20, T-25, T-30, T-40
- 4 - 1/4" Dr. Bit Socket HEX 3mm, 4mm, 5mm, 6mm
- 4 - 1/4" Dr. Bit Socket PHILLIPS #1, #2
- 3 - 5/16" Dr. Bits SLOTTED 8, 10, 12mm
- 2 - 5/16" Dr. Bits PHILLIPS #3, #4
- 2 - 5/16" Dr. Bits PHILLIPS #3, #4
- 4 - 5/16" Dr. Bits TORX T-40, T-45, T-50, T-55
- 4 - 5/16" Dr. Bits HEX 8, 10, 12, 14mm
- 1 - 3/8" Dr. 3-Way Joint

- Box Size: 420x315x80mm
- Cold-forged 50BV30#Cr-V.

PART #	CONTENTS	ΔTΔ	📦
E1227	86PCS	6.5kg	6

15PC. 1/2" Dr. SOCKET SET



- 1 - 1/2" Dr. Extension Bar 5"
- 1 - 1/2" Dr. Spark Plug Socket 16mm
- 1 - 1/2" Dr. Quick-Release Ratchet
- 12 - 1/2" Dr. 6PT. Socket 10,11,12,13,14,15,16,17,18,19,22,24mm

- Box Size: 250x185x52mm
- Cold-forged 50BV30#Cr-V.

PART #	CONTENTS	ΔTΔ	📦
E1212	15PCS	2.2kg	6

27PC. 1/2" Dr. SOCKET SET



- 10 - 1/2" Dr. 6PT. Socket 8,9,10,11,12,13,14,15,16,17mm
- 10 - 1/2" Dr. 6PT. Socket 18,19,20,21,22,23,24,27,30,32mm
- 1 - 1/2" Dr. Quick-Release Ratchet
- 2 - 1/2" Dr. Extension Bar 5", 10"
- 1 - 1/2" Dr. 3-Way Joint
- 2 - 1/2" Dr. Spark Plug Socket 16,21mm
- 1 - 1/2" Dr. Universal Joint

- Box Size: 380x260x80mm
- Cold-forged 50BV30#Cr-V.

PART #	CONTENTS	ΔTΔ	📦
E1213	27PCS	4.3kg	6

33PC. 1/4" Dr. SOCKET SET



- 12 - 1/4" Dr. 6PT. Socket 4,4.5,5.5,6,7,8,9,10,11,12,13mm
- 1 - 1/4" Dr. Quick-Release Ratchet
- 1 - 1/4" Dr. Bit Adapter
- 3 - 1/4" Dr. 25mm Bits Slotted 4,5,5.6,5.5mm
- 3 - 1/4" Dr. 25mm Bits Phillips #1, #2, #3
- 6 - 1/4" Dr. 25mm Bits Hex 2,2.5,3,4,5,6mm
- 6 - 1/4" Dr. 25mm Bits Torx T10, T15, T20, T25, T27, T30
- 1 - Spinner Handle

- Box Size: 250x185x52mm
- Cold-forged 50BV30#Cr-V.

PART #	CONTENTS	ΔTΔ	📦
E1214	33PCS	0.77kg	18

40PC. 1/4" + 3/8" Dr. SOCKET SET



- 1 - 1/4" Dr. 6PT. Socket 4,4.5,5.5,6,7,8,9mm
- 3 - 1/4" Dr. 25mm Bits Slotted 4,5,5.6,5.5mm
- 3 - 1/4" Dr. 25mm Bits Phillips #1, #2, #3
- 6 - 1/4" Dr. 25mm Bits Hex 2,2.5,3,4,5,6mm
- 1 - 1/4" Dr. Spinner Handle
- 1 - 1/4" Dr. Bit Adapter
- 1 - 1/4" Dr. 3-Way Joint
- 3 - Hex Key 1.5, 2, 2.5mm
- 5 - 3/8" Dr. 6PT. Socket 10,11,12,13,14mm
- 5 - 3/8" Dr. 6PT. Socket 15,16,17,18,19mm
- 1 - 3/8" Dr. Spark Plug Socket 16mm
- 1 - 3/8" Dr. Quick-Release Ratchet
- 1 - 3/8" Dr. Universal Joint
- 1 - 3/8" Dr. Extension Bar 6"

- Box Size: 380x260x80mm
- Cold-forged 50BV30#Cr-V.

PART #	CONTENTS	ΔTΔ	📦
E1215	40PCS	1.8kg	6

21PC. 1/2" Dr. SOCKET SET



- 7 - 1/2" Dr. 6PT. Socket 10,11,12,13,14,15,16mm
- 6 - 1/2" Dr. 6PT. Socket 17,18,19,21,22,24mm
- 3 - 1/2" Dr. 6PT. Deep Socket 13,17,19mm
- 1 - 1/2" Dr. Quick-Release Ratchet
- 1 - 1/2" Dr. Extension Bar 10"
- 1 - 1/2" Dr. 3-Way Joint
- 1 - 1/2" Dr. Spark Plug Socket 16mm
- 1 - 1/2" Dr. Universal Joint

- Box Size: 280x205x62mm
- Cold-forged 50BV30#Cr-V.

PART #	CONTENTS	ΔTΔ	📦
E1216	21PCS	2.9kg	6

32PC. 1/2" Dr. SOCKET SET



- 10 - 1/2" Dr. 6PT. Socket 8,9,10,11,12,13,14,15,16,17mm
- 9 - 1/2" Dr. 6PT. Socket 18,19,20,21,22,24,27,30,32mm
- 6 - 1/2" Dr. 12PT. Socket 10,12,14,15,17,19mm
- 1 - 1/2" Dr. Quick-Release Ratchet
- 2 - 1/2" Dr. Extension Bar 5", 10"
- 1 - 1/2" Dr. 3-Way Joint
- 2 - 1/2" Dr. Spark Plug Socket 16mm, 21mm
- 1 - 1/2" Dr. Universal Joint

- Box Size: 380x260x80mm
- Cold-forged 50BV30#Cr-V.

PART #	CONTENTS	ΔTΔ	📦
E1217	32PCS	3.1kg	6

32PC. 1/2" Dr. SOCKET SET SET



- 10 - 1/2" Dr. 6PT. Socket 8,9,10,11,12,13,14,15,16,17mm
- 10 - 1/2" Dr. 6PT. Socket 18,19,20,21,22,23,24,27,30,32mm
- 5 - 1/2" Dr. 6PT. Impact Socket 14,17,19,21,24mm
- 1 - 1/2" Dr. Quick-Release Ratchet
- 2 - 1/2" Dr. Extension Bar 5", 10"
- 1 - 3/8" Dr. 3-Way Joint
- 1 - 1/2" Dr. Speed Brace
- 1 - 1/2" Dr. Universal Joint
- 1 - 1/2" Dr. L-Type Wrench 250mm

- Box Size: 420x315x80mm
- Cold-forged 50BV30#Cr-V.

PART #	CONTENTS	ΔTΔ	📦
E1217A	32PCS	3.0kg	6

58PC. 3/8" Dr. SOCKET SET



- 18 - 3/8" Dr. 6PT. Socket 6,7,8,9,10,11,12,13,14,15,16,17,18,19,20,21,22,24mm
- 9 - 3/8" Dr. 6PT. Deep Socket 8,10,11,12,13,14,15,17,19mm
- 2 - 3/8" Dr. Spark Plug Socket 16,21mm
- 2 - 3/8" Dr. Extension Bar 3", 10"
- 1 - 3/8" Dr. Quick-release Ratchet
- 1 - 3/8" Dr. Universal Joint
- 1 - 3/8" Dr. 3 Way Joint (Female: 10MM, Male: 12.5MM)
- 9 - 3/8" Dr. Bit Socket TORX T10, T15, T20, T25, T30, T40, T45, T50, T55
- 7 - 3/8" Dr. Bit Socket HEX 3,4,5,6,7,8,10
- 2 - 3/8" Dr. Bit Socket PHILLIPS #1, #2
- 3 - 3/8" Dr. Bit Socket PHILLIPS #1, #2, #3
- 3 - 3/8" Dr. Bit Socket SLOTTED 5.5, 6.5, 8.0mm

- Box Size: 380x260x80mm
- Cold-forged 50BV30#Cr-V.

PART #	CONTENTS	ΔTΔ	📦
E1228	58PCS	6.0kg	6

58PC. 1/2" Dr. SOCKET SET



- 9 - 1/2" Dr. 6PT. Socket 10, 11, 12, 13, 14, 15, 16, 17, 18mm
- 8 - 1/2" Dr. 6PT. Socket 19, 20, 21, 22, 24, 27, 30, 32mm
- 8 - 1/2" Dr. 6PT. Deep Socket 10, 11, 12, 13, 14, 15, 17, 19mm
- 5 - 5/16" Dr. 30L Bit Slotted 5.5, 6.5, 8, 10, 12mm
- 4 - 5/16" Dr. 30L Bit Phillips #1, #2, #3, #4
- 4 - 5/16" Dr. 30L Bit Torx 6 Bit 5, 6, 8, 10mm
- 7 - 5/16" Dr. 30L Bit Torx T40, T20, T25, T30, T45, T50, T55
- 1 - 1/2" Dr. Quick-release Ratchet
- 2 - 1/2" Dr. Extension Bar 5", 10"
- 1 - 1/2" Dr. Sliding Bar
- 1 - 1/2" Dr. Socket Adapter 5/16"
- 2 - 1/2" Dr. Spark Plug Socket 16,21mm
- 1 - 1/2" Dr. Universal Joint.

- Box Size: 380x260x80mm
- Cold-forged 50BV30#Cr-V.

PART #	CONTENTS	ΔTΔ	📦
E1233	58PCS	5.4kg	6

25PC. 1/4" Dr. SOCKET SET



- 8 - 1/4" Dr. 6PT. Socket 4, 4.5, 5, 5.5, 6, 7, 8, 9mm
- 5 - 1/4" Dr. 6PT. Socket 10,11,12,13,14mm
- 5 - 1/4" Dr. 6PT. Deep Socket 8,10,11,12,13mm
- 1 - 1/4" Dr. Quick-release Ratchet
- 2 - 1/4" Dr. Extension Bar 2", 4"
- 1 - 1/4" Dr. Sliding Bar
- 1 - 1/4" Dr. Universal Joint
- 1 - 1/4" Dr. Bit Adapter
- 1 - 1/4" Dr. Spinner Handle

- Box Size: 280x185x52mm
- Cold-forged 50BV30#Cr-V.

PART #	CONTENTS	ΔTΔ	📦
E1231	25PCS	1.35kg	6

38PC. 1/4" Dr. SOCKET SET



- 8 - 1/4" Dr. 6PT. Socket 4,4.5,5.5,6,7,8,9mm
- 5 - 1/4" Dr. 6PT. Socket 10,11,12,13,14mm
- 3 - 1/4" Dr. Bit Socket Slotted 4,5,5.6,5.5mm
- 4 - 1/4" Dr. Bit Socket Phillips #1, #2, #3, #4
- 4 - 1/4" Dr. Bit Socket Hex 3,4,5,6mm
- 7 - 1/4" Dr. Bit Socket Torx T8, T10, T15, T20, T25, T30, T40
- 1 - 1/4" Dr. Quick-release Ratchet
- 2 - 1/4" Dr. Extension Bar 2", 4"
- 1 - 1/4" Dr. Sliding Bar
- 1 - 1/4" Dr. Universal Joint
- 1 - 1/4" Dr. Bit Adapter
- 1 - 1/4" Dr. Spinner Handle

- Box Size: 250x185x52mm
- Cold-forged 50BV30#Cr-V.

PART #	CONTENTS	ΔTΔ	📦
E1232	38PCS	1.3kg	6

24PC. 1/2" Dr. SOCKET SET



- 20 - 1/2" Dr. 6PT. Socket 8,9,10,11,12,13,14,15,16,17,18,19,20,21,22,23,24,27,30,32mm
- 1 - 1/2" Dr. Quick-release Ratchet
- 1 - 1/2" Dr. Universal Joint
- 1 - 1/2" Dr. Extension Bar 10"
- 1 - 3/8" Dr. 3-Way Joint

- Box Size: 380x260x80mm
- Cold-forged 50BV30#Cr-V.

PART #	CONTENTS	ΔTΔ	📦
E1219	24PCS	3.6kg	6

48PC. 1/2" Dr. SOCKET SET



- 20 - 1/2" Dr. 6PT. Socket 8,9,10,11,12,13,14,15,16,17,18,19,20,21,22,23,24,27,30,32mm
- 8 - 1/2" Dr. 6PT. Deep Socket 10,11,12,13,14,15,17,19mm
- 3 - 3/8" Dr. Bits Socket SLOTTED 5.5,6.5,8.0mm
- 3 - 3/8" Dr. Bits Sockets PHILLIPS PH1, PH2, PH3
- 3 - 3/8" Dr. Bits Socket HEX 4,5,6mm
- 3 - 3/8" Dr. Bits Socket TORX T10, T20, T30
- 1 - 1/2" Dr. Bit Adapter
- 2 - 1/2" Dr. Quick-release Ratchet
- 1 - 1/2" Dr. Universal Joint
- 2 - 1/2" Dr. Spark Plug Socket 6,21mm
- 1 - 1/2" Dr. Extension Bar 5"
- 1 - 1/2" Dr. Extension Bar 10"
- 1 - 1/2" Dr. Flexible Handle 15"

- Box Size: 380x260x80mm
- Cold-forged 50BV30#Cr-V.

PART #	CONTENTS	ΔTΔ	📦
E1218	48PCS	6.1kg	6

3/4" Dr. SOCKET SET

3/4"



15PC

10 - 3/4" Dr. 12PT. Socket 30,32,34,36,38,41,46,50, 55,60mm
 1 - 3/4" Dr. Quick-release Ratchet
 4 - 3/4" Dr. Extension Bar 4 " ,8" ,Sliding Bar 450mm, Universal Joint

21PC

16 - 3/4" Dr. 12PT. Socket 19,21,22,23,24,26,27,30,32, 34,36,38,41,46,48,50mm
 1 - 3/4" Dr. Quick-release Ratchet
 4 - 3/4" Dr. Extension Bar 4 " ,8" ,Sliding Bar 450mm, Universal Joint

26PC

21 - 3/4" Dr. 12PT. Socket 19,21,22,23,24,26,27,28,29, 30,31,32,34,36,38,41,46,50,55,60,65mm
 1 - 3/4" Dr. Quick-release Ratchet
 4 - 3/4" Dr. Extension Bar 4 " ,8" ,Sliding Bar 450mm, Universal Joint

- Box Size: 540x180x80mm
- Cold-forged 50BV30#Cr-V.

PART #	CONTENTS	ΔΔ	📦
E1225	15PCS	6.0kg	1
E1246	21PCS	6.5kg	1
E1247	26PCS	7.0kg	1

1" Dr. SOCKET SET

1"



14PC

9 - 1" Dr. 6PT. Socket 46,48,50,55,60,65,70,75,80mm
 1 - 1" Dr. Quick-release Ratchet
 4 - 1" Dr. Extension Bar 8",16",Sliding T-bar,L-type Handle

21PC

16 - 1" Dr. 12PT. Socket 30,31,32,34,36,38,41,46,48,50, 55,60,65,70,75,80mm
 1 - 1" Dr. Quick-release Ratchet
 4 - 1" Dr. Extension Bar 8",16",Sliding T-bar,L-type Handle

- Box Size: 683x248x100mm
- Cold-forged 50BV30#Cr-V.

PART #	CONTENTS	ΔΔ	📦
E1248	14PC	6.5kg	1
E1249	21PC	7.0kg	1

24PC. 1/4" Dr. SOCKET SET

1/4"



13-1/4" Dr. 6PT. Socket 4,4.5,5,5.5,6,7,8,9,10,11,12,13,14mm
 5-1/4" Dr. 6PT. Deep Socket 8,10,11,12,13mm
 1-1/4" Dr. Quick-release Ratchet
 1-1/4" Dr. Sliding Bar
 2-1/4" Dr. Extension Bar 2" , 4"
 1-1/4" Dr. Universal Joint
 1-1/4" Dr. Spinner Handle

- Box Size: 380x140x52mm
- Cold-forged 50BV30#Cr-V.

PART #	CONTENTS	ΔΔ	📦
E1229	24PCS	1.8kg	1

34PC. 3/8" Dr. SOCKET SET

3/8"



18 - 3/8" Dr. 6PT. Socket 6,7,8,9,10,11,12,13,14,15,16,17, 18,19,20,21,22,24mm
 9 - 3/8" Dr. 6PT. Deep Socket 8,10,11,12,13,14,15,17,19mm
 1 - 3/8" Dr. Spark Plug Socket 16,21mm
 1 - 3/8" Dr. Quick-Release Ratchet
 1 - 3/8" Dr. Universal Joint
 1 - 3/8" Dr. Extension Bar 3",10"
 1 - 3/8" Dr. 3-Way Joint
 1 - 1/4" Dr. Sliding T-bar

- Box Size: 440x190x52mm
- Cold-forged 50BV30#Cr-V.

PART #	CONTENTS	ΔΔ	📦
E1224	34PCS	3.9kg	1

24PC. 1/2" Dr. SOCKET SET

1/2"



18 - 1/2" Dr. 6PT. Socket 10,11,12,13,14,15,16,17,18,19, 20,21,22,23,24,27,30,32mm
 1 - 1/2" Dr. Quick-release Ratchet
 2 - 1/2" Dr. Extension Bar 5",10"
 1 - 1/2" Dr. Universal Joint
 1 - 3/8" Dr. 3-Way Joint
 1 - 1/2" Dr. Flexible Handle 10"

- Box Size: 440x190x52mm
- Cold-forged 50BV30#Cr-V.

PART #	CONTENTS	ΔΔ	📦
E1235	24PCS	4.97kg	1

38PC. 1/4" Dr. SOCKET SET

1/4"



13-1/4" Dr. 6PT. Socket 4,4.5,5,5.5,6,7,8,9,10,11,12,13,14mm
 3-1/4" Dr. Bit Socket Slotted 4,5,5.5,6,5mm
 3-1/4" Dr. Bit Socket Phillips #1, #2,#3
 5-1/4" Dr. Bit Socket Hex 3,4,5,6,8mm
 7-1/4" Dr. Bit Socket Torx T8,T10,T15,T20,T25,T30,T40
 1-1/4" Dr. Quick-release Ratchet
 1-1/4" Dr. Sliding Bar
 2-1/4" Dr. Extension Bar 2" , 4"
 1-1/4" Dr. Universal Joint
 1-1/4" Dr. Spinner Handle
 1-1/4" Dr. Bit Adapter

- Box Size: 380x140x52mm
- Cold-forged 50BV30#Cr-V.

PART #	CONTENTS	ΔΔ	📦
E1230	38PCS	1.68kg	1

20PC. 1/2" Dr. SOCKET SET

1/2"



12 - 1/2" Dr. 6PT. Socket 10,11,12,13,14,15,16,17,18,1 9,22,24mm
 3 - 1/2" Dr. 6PT. Deep Socket 13,17,19mm
 1 - 1/2" Dr. Quick-release Ratchet
 1 - 1/2" Dr. Extension Bar 10"
 1 - 1/2" Dr. Universal Joint
 1 - 3/8" Dr. 3-Way Joint
 1 - 1/2" Dr. Spark Plug Socket 16mm

- Box Size: 440x190x52mm
- Cold-forged 50BV30#Cr-V.

PART #	CONTENTS	ΔΔ	📦
E1234	20PCS	3.95kg	1

32PC. 1/2" Dr. SOCKET SET

1/2"



21 - 1/2" Dr. 6PT. Socket 8,9,10,11,12,13,14,15,16,17,18, 19,20,21,22,23,24,27,30,32,34mm
 5 - 1/2" Dr. 12PT. Deep Socket 10,12,14,17,19mm
 1 - 1/2" Dr. Quick-release Ratchet
 2 - 1/2" Dr. Extension Bar 5",10"
 1 - 1/2" Dr. Universal Joint
 1 - 1/2" Dr. L-Type Wrench
 1 - 1/2" Dr. Speed Brace

- Box Size: 440x190x52mm
- Cold-forged 50BV30#Cr-V.

PART #	CONTENTS	ΔΔ	📦
E1236	32PCS	6.18kg	1

PROFESSIONAL QUICK-RELEASE RATCHET



- Made of Cr-V
- Super torsion and durable

1/4" Dr. 6PT. SOCKET

1/4"



- Drop-forged 50BV30#Cr-V.
- Meet and exceed ANSI B107.5-1994 D/N899-1980.

PART #	SIZE	LENGTH	📦
E3102	4mm	24.5mm	12
E3103	4.5mm	24.5mm	12
E3104	5mm	24.5mm	12
E3105	5.5mm	24.5mm	12
E3106	6mm	24.5mm	12
E3107	7mm	24.5mm	12
E3108	8mm	24.5mm	12
E3109	9mm	24.5mm	12
E3110	10mm	24.5mm	12
E3111	11mm	24.5mm	12
E3112	12mm	24.5mm	12
E3113	13mm	24.5mm	12
E3114	14mm	24.5mm	12

1/4" Dr. DEEP SOCKET

1/4"



- Drop-forged 50BV30#Cr-V.
- Meet and exceed ANSI B107.5-1994 D/N899-1980.

PART #	SIZE	LENGTH	📦
E3133	4mm	49.0mm	12
E3134	5mm	49.0mm	12
E3135	5.5mm	49.0mm	12
E3136	6mm	49.0mm	12
E3137	7mm	49.0mm	12
E3138	8mm	49.0mm	12
E3139	9mm	49.0mm	12
E3140	10mm	49.0mm	12
E3141	11mm	49.0mm	12
E3142	12mm	49.0mm	12
E3143	13mm	49.0mm	12

QUICK-RELEASE RATCHET

1/4"



- Drop-forged 50BV30#Cr-V.Quick-release capability.
- Meet and exceed ANSI B107.10M-1996,DIN 3122-1976.

PART #	DRIVER	LENGTH	📦
E3201	1/4"	125.0mm	6

QUICK-RELEASE RATCHET

1/4"



- Drop-forged 50BV30#Cr-V.
- Meet and exceed ANSI B107.10M-1996,DIN 3122-1976.

PART #	DRIVER	LENGTH	📦
E3202	1/4"	125.0mm	6

EXTENTION BAR

1/4"



- Drop-forged 50BV30#Cr-V.
- Meet and exceed ANSIANSI B107.10M-1996,DIN 3123-1976.

PART #	DRIVER	SIZE	LENGTH	📦
E3204	1/4"	2"	50.0mm	12
E3205	1/4"	4"	100.0mm	12

SLIDING T-BAR

1/4"



- Drop-forged 50BV30#Cr-V.
- Meet and exceed ANSIANSI B107.10M-1996,DIN 3123-1976.

PART #	DRIVER	LENGTH	📦
E3206	1/4"	100.0mm	12

UNIVERSAL JOINT

1/4"



- Drop-forged 50BV30#Cr-V.
- Meet and exceed ANSI B107.10-1996,DIN 3123-1976.

PART #	DRIVER	📦
E3208	1/4"	12

1/4" Dr. BIT ADAPTER

1/4"



- Drop-forged 50BV30#Cr-V.
- Meet and exceed ANSI B107.10-1996,DIN 3123-1976.

PART #	DRIVER	📦
E3209	1/4"	12

1/4" Dr. SPINNER HANDLE

1/4"



- Drop-forged 50BV30#Cr-V.Plugged by a ratchet at the end.
- Meet and exceed ANSI B107.10-1996DIN 3123-1976.

PART #	DRIVER	📦
E3210	1/4"	12

3/8" Dr. 6PT. SOCKET

3/8"



PART #	SIZE	LENGTH	
E3306	6mm	25.0mm	12
E3307	7mm	25.0mm	12
E3308	8mm	25.0mm	12
E3309	9mm	25.0mm	12
E3310	10mm	25.0mm	12
E3311	11mm	25.0mm	12
E3312	12mm	25.0mm	12
E3313	13mm	25.0mm	12
E3314	14mm	25.0mm	12
E3315	15mm	25.0mm	12
E3316	16mm	25.0mm	12
E3317	17mm	25.0mm	12
E3318	18mm	25.0mm	12
E3319	19mm	28.0mm	12
E3320	20mm	28.0mm	12
E3321	21mm	28.0mm	12
E3322	22mm	31.5mm	12
E3324	24mm	31.5mm	12

3/8" Dr. 6PT DEEP SOCKET

3/8"



- Drop-forged 50BV30#Cr-V.
- Meet and exceed ANSI B107.5-1994 DIN899-1980.

PART #	SIZE	LENGTH	
E3338	8mm	63.5mm	12
E3339	9mm	63.5mm	12
E3340	10mm	63.5mm	12
E3341	11mm	63.5mm	12
E3342	12mm	63.5mm	12
E3343	13mm	63.5mm	12
E3344	14mm	63.5mm	12
E3345	15mm	63.5mm	12
E3346	16mm	63.5mm	12
E3347	17mm	63.5mm	12
E3348	18mm	63.5mm	12
E3349	19mm	63.5mm	12
E3350	20mm	63.5mm	12
E3351	21mm	63.5mm	12
E3352	22mm	63.5mm	12

3/8" Dr. 6PT STAR SOCKET

3/8"



- Drop-forged 50BV30#Cr-V.
- Meet and exceed ANSI B107.5-1994 DIN899-1980.

PART #	SIZE	LENGTH	
E3361	E8	24.5mm	12
E3362	E10	24.5mm	12
E3363	E11	24.5mm	12
E3364	E12	24.5mm	12
E3365	E14	24.5mm	12
E3366	E16	24.5mm	12
E3367	E18	24.5mm	12
E3368	E20	24.5mm	12

QUICK-RELEASE RATCHET

3/8"



- Quick-release, Drop-forged 50BV30#Cr-V.
- Meet and exceed ANSI B107.10M-1996,DIN 3122-1976.

PART #	DRIVER	LENGTH	
E3401	3/8"	200.0mm	6

QUICK-RELEASE RATCHET

3/8"



- Quick-release capability; single hand operation.Drop-forged 50BV30#Cr-V.
- Meet and exceed ANSI B107.10M-1996,DIN 3122-1976.

PART #	DRIVER	LENGTH	
E3402	3/8"	200.0mm	6

EXTENTION BAR

3/8"



- Drop-forged 50BV30#Cr-V.
- Meet and exceed ANSI B107.10M-1996,DIN 3123-1976.

PART #	DRIVER	LENGTH	
E3404	3/8"	75.0mm	12
E3405	3/8"	150.0mm	12
E3415	3/8"	250.0mm	12

SLIDING T-BAR

3/8"



- Drop-forged 50BV30#Cr-V.
- Meet and exceed ANSI B107.10M-1996,DIN 3123-1976.

PART #	DRIVER	LENGTH	
E3406	3/8"	200.0mm	12

UNIVERSAL JOINT

3/8"



- Drop-forged 50BV30#Cr-V.
- Meet and exceed ANSI B107.10-1996,DIN 3123-1976.

PART #	DRIVER	
E3407	3/8"	12

SOCKET ADAPTER

3/8"



- Drop-forged 50BV30#Cr-V.
- Meet and exceed ANSI B107.10M-1996,DIN 3123-1976.

PART #	DRIVER	MALE	
E3408	3/8"	1/4"	12
E3409	3/8"	1/2"	12

SPARK PLUG SOCKET

3/8"



- Drop-forged 50BV30#Cr-V.
- Meet and exceed ANSI B107.34.

PART #	DRIVER	SIZE	
E3410	3/8"	16mm	12
E3411	3/8"	21mm	12

EXTENDED FLEX SPARK PLUG SOCKET

3/8"



- Drop-forged 50BV30#Cr-V.Heated treated.
- Can be forced from different angles, suitable for use in a narrow space

PART #	DRIVER	SIZE	
E3417	3/8"	16mm	6
E3418	3/8"	21mm	6

3/8" Dr. 3-WAY ADAPTER

3/8"



- Drop-forged 50BV30#Cr-V.
- Meet and exceed ANSI B107.10M-1996,DIN 3123-1976.

PART #	DRIVER	MALE	
E3412	3/8"	1/2"	12

1/2" Dr. 6PT. SOCKET

1/2"



- Drop-forged 50BV30#Cr-V.
- Meet and exceed ANSI B107.5-1994 DIN899-1980.

PART #	SIZE	LENGTH	
E3508	8mm	37.8mm	12
E3509	9mm	37.8mm	12
E3510	10mm	37.8mm	12
E3511	11mm	37.8mm	12
E3512	12mm	37.8mm	12
E3513	13mm	37.8mm	12
E3514	14mm	37.8mm	12
E3515	15mm	37.8mm	12
E3516	16mm	37.8mm	12
E3517	17mm	37.8mm	12
E3518	18mm	37.8mm	12
E3519	19mm	37.8mm	12
E3520	20mm	37.8mm	12
E3521	21mm	37.8mm	12
E3522	22mm	40.0mm	12
E3523	23mm	40.0mm	12
E3524	24mm	40.0mm	12
E3527	27mm	43.0mm	12
E3530	30mm	43.0mm	12
E3532	32mm	43.0mm	12
E3534	34mm	43.0mm	12

1/2" Dr. 12PT SOCKET

1/2"



- Drop-forged 50BV30#Cr-V.
- Meet and exceed ANSI B107.5-1994 DIN899-1980.

PART #	SIZE	LENGTH	
E3610	10mm	37.8mm	12
E3612	12mm	37.8mm	12
E3614	14mm	37.8mm	12
E3615	15mm	37.8mm	12
E3617	17mm	37.8mm	12
E3619	19mm	37.8mm	12

1/2" Dr. 6PT DEEP SOCKET

1/2"



- Drop-forged 50BV30#Cr-V.
- Meet and exceed ANSI B107.5-1994 DIN899-1980.

PART #	SIZE	LENGTH	
E3710	10mm	72.0mm	12
E3711	11mm	72.0mm	12
E3712	12mm	72.0mm	12
E3713	13mm	72.0mm	12
E3714	14mm	72.0mm	12
E3715	15mm	72.0mm	12
E3716	16mm	72.0mm	12
E3717	17mm	72.0mm	12
E3718	18mm	72.0mm	12
E3719	19mm	72.0mm	12
E3720	20mm	72.0mm	12
E3721	21mm	72.0mm	12
E3722	22mm	72.0mm	12
E3724	24mm	72.0mm	12
E3727	27mm	72.0mm	12

QUICK-RELEASE RATCHET

1/2"



- Quick-release, Drop-forged 50BV30#Cr-V.
- Meet and exceed ANSI B107.10M-1996,DIN 3122-1976.

PART #	DRIVER	LENGTH	
E4512	1/2"	250.0mm	6

QUICK-RELEASE RATCHET

1/2"



- Quick-release, Drop-forged 50BV30#Cr-V.
- Meet and exceed ANSI B107.10M-1996,DIN 3122-1976.

PART #	DRIVER	LENGTH	
E4513	1/2"	250.0mm	6

EXTENTION BAR

1/2"



- Drop-forged 50BV30#Cr-V.
- Meet and exceed ANSI B107.10M-1996,DIN 3123-1976.

PART #	DRIVER	SIZE	LENGTH	
E4533	1/2"	5"	125.0mm	12
E4535	1/2"	10"	250.0mm	12

SPEED BRACE

1/2"



- Drop-forged 50BV30#Cr-V.
- Meet and exceed ANSI B107.10-1996,DIN 3123-1976.

PART #	DRIVER	
E4547	1/2"	6

FLEXIBLE HANDLE

1/2"



- Drop-forged 50BV30#Cr-V.

PART #	LENGTH	SIZE	
E4549	250.0mm	10"	6
E4550	359.0mm	15"	6

SLIDING T-BAR

1/2"



- Drop-forged 50BV30#Cr-V.
- Meet and exceed ANSI B107.10M-1996,DIN 3123-1976.

PART #	DRIVER	LENGTH	
E4536	1/2"	260.0mm	12

SOCKET ADAPTER

1/2"



- Drop-forged 50BV30#Cr-V.
- Meet and exceed ANSI B107.10M-1996,DIN 3123-1976.

PART #	DRIVER	MALE	
E4537	1/2"	3/8"	12

SPARK PLUG SOCKET

1/2"



- Drop-forged 50BV30#Cr-V.
- Meet and exceed ANSI B107.34.

PART #	DRIVER	SIZE	
E4541	1/2"	16mm	12
E4542	1/2"	21mm	12

UNIVERSAL JOINT

1/2"



- Drop-forged 50BV30#Cr-V.
- Meet and exceed ANSI B107.10-1996,DIN 3123-1976.

PART #	DRIVER	
E4551	1/2"	12

1/2"DR.L-TYPE WRENCH

1/2"



- Drop-forged 50BV30#Cr-V.
- Meet and exceed ANSI B107,DIN 3122.

PART #	DRIVER	LENGTH	
E4546	1/2"	250.0mm	6

WHEEL WRENCH



- Non-extendable.

PART #	DRIVER	LEN
E4558	320mm	6

4WAY LUG WRENCH



- Can be separated, easy to carry.
- Standard 1/2" interface, which can be used with different sleeve specifications
- Forged, heat treated, durable.

PART #	SIZE	LEN
E4568	17,23,25,40mm,1/2"BAR&JOINT	4

Y TYPE SOCKET WRENCH



- Cr-V Steel

PART #	SIZE	LEN
E4576	10-12-14 mm	6
E4577	12-14-17mm	6

3PC.EXTENSION WHEEL WRENCH SET



- 1-Extendable Wheel Wrench
- 2-2-1/2" Socket 17-19mm, 21-23mm

PART #	CONTENTS	Min Length	Max Length	LEN
E4570	3PCS	340.0mm	520.0mm	6
E4554	TIRE WRENCH	340.0mm	520.0mm	6

4WAY LUG WRENCH



- Cr-V. Steel
- One end to connect socket. another 3ends, 17,19,21mm sockets.

PART #	SIZE	LEN
E4553	17,19,21mm,1/2"JOINT	3

T TYPE SOCKET WRENCH



- Cr-V. Steel

PART #	SIZE	LENGTH	LEN
E4581	8mm	310.0mm	6
E4583	10mm	310.0mm	6
E4585	12mm	310.0mm	6
E4586	13mm	310.0mm	6
E4587	14mm	310.0mm	6
E4588	17mm	310.0mm	6
E4591	6mm	310.0mm	6
E4582	9mm	310.0mm	6
E4584	11mm	310.0mm	6
E4592	15mm	310.0mm	6
E4590	16mm	310.0mm	6
E4589	19mm	310.0mm	6

ENDURA®
A Textron Company

4WAY LUG WRENCH



- Cr-V. Steel. Suitable for disassemble and maintenance of heavy vehicle tires.
- One end to connect socket, another 3ends:22,24,27mm socket.

PART #	SIZE	LEN
E4552	22,24,27mm,3/4 "JOINT	3
E4559	22,24,27mm,3/4 "JOINT	3

3/4" Dr. 12PT. SOCKET

3/4"



- Drop-forged 50BV30#Cr-V.
- Meet and exceed ANSI B107.5M DIN3124.

PART #	SIZE	LENGTH	LEN
E4601	19mm	50.0mm	2
E4602	21mm	50.0mm	2
E4603	22mm	50.0mm	2
E4604	23mm	51.0mm	2
E4605	24mm	51.0mm	2
E4607	26mm	52.0mm	2
E4608	27mm	52.0mm	2
E4609	28mm	54.0mm	2
E4610	29mm	54.0mm	2
E4611	30mm	56.0mm	1
E4623	31mm	56.0mm	1
E4612	32mm	56.0mm	1
E4614	34mm	56.0mm	1
E4616	36mm	58.0mm	1
E4617	38mm	60.0mm	1
E4618	41mm	64.0mm	1
E4619	46mm	68.0mm	1
E4624	48mm	70.0mm	1
E4620	50mm	72.0mm	1
E4621	55mm	76.0mm	1
E4622	60mm	78.0mm	1
E4625	65mm	80.0mm	1

1"Dr. 12PT SOCKET

1"



- Drop-forged 50BV30#Cr-V.
- Meet and exceed ANSI B 107.5M DIN3124.

PART #	SIZE	LENGTH	LEN
E4659	30mm	60.0mm	1
E4660	31mm	60.0mm	1
E4661	32mm	60.0mm	1
E4662	34mm	60.0mm	1
E4663	36mm	65.0mm	1
E4664	38mm	65.0mm	1
E4665	41mm	70.0mm	1
E4666	46mm	75.0mm	1
E4667	48mm	75.0mm	1
E4668	50mm	75.0mm	1
E4669	55mm	83.0mm	1
E4670	60mm	87.0mm	1
E4671	65mm	90.0mm	1
E4672	70mm	93.0mm	1
E4673	75mm	97.0mm	1
E4674	80mm	103.0mm	1

PROFESSIONAL PATCHET

3/4" 1"



- Quick-release

PART #	DRIVER	LENGTH	LEN
E4641	3/4"	510.0mm	1
E4681	1"	800.0mm	1

3/4"Dr. UNIVERSAL JOINT

3/4"



PART #	DRIVER	LEN
E4647	3/4"	6

L-TYPE HANDLE

3/4" 1"



PART #	DRIVER	LEN
E4648	3/4"	3
E4685	1"	3

EXTENSION BAR

3/4" 1"



PART #	DRIVER	LENGTH	LEN
E4642	3/4"	100mm	6
E4643	3/4"	200mm	4
E4682	1"	200mm	4
E4683	1"	400mm	2

SLIDING T-BAR

3/4" 1"



PART #	DRIVER	LENGTH	LEN
E4645	3/4"	450.0mm	3
E4684	1"	520.0mm	3

ENDURA®
A Textron Company

1/4"Dr. BIT SOCKETS SLOTTED



- S2 alloy steel. High torque and tenacity.

PART #	SIZE	LENGTH	📦
E4112	4.0mm	37.0mm	12
E4113	5.5mm	37.0mm	12
E4114	6.5mm	37.0mm	12

1/4"Dr. BIT SOCKETS PHILLIPS



- S2 alloy steel. High torque and tenacity.

PART #	SIZE	LENGTH	📦
E4122	#1	37.0mm	12
E4123	#2	37.0mm	12

1/4"Dr. BIT SOCKETS HEX



- S2 alloy steel. High torque and tenacity.

PART #	SIZE	LENGTH	📦
E4132	3mm	37.0mm	12
E4133	4mm	37.0mm	12
E4134	5mm	37.0mm	12
E4135	6mm	37.0mm	12

1/4"Dr. BIT SOCKETS TORX



- S2 alloy steel. High torque and tenacity.

PART #	SIZE	LENGTH	📦
E4141	T8	37.0mm	12
E4142	T10	37.0mm	12
E4143	T15	37.0mm	12
E4144	T20	37.0mm	12
E4145	T25	37.0mm	12
E4147	T30	37.0mm	12
E4148	T40	37.0mm	12

3/8"Dr. BIT SOCKETS SLOTTED



- S2 alloy steel. High torque and tenacity.

PART #	SIZE	LENGTH	📦
E4212	5.5mm	50.0mm	12
E4213	6.5mm	50.0mm	12
E4214	8.0mm	50.0mm	12

3/8"Dr. BIT SOCKETS PHILLIPS



- S2 alloy steel. High torque and tenacity.

PART #	SIZE	LENGTH	📦
E4222	#1	50.0mm	12
E4223	#2	50.0mm	12
E4224	#3	50.0mm	12

3/8"Dr. BIT SOCKETS HEX



- S2 alloy steel. High torque and tenacity.

PART #	SIZE	LENGTH	📦
E4232	3mm	50.0mm	12
E4233	4mm	50.0mm	12
E4234	5mm	50.0mm	12
E4235	6mm	50.0mm	12
E4236	7mm	50.0mm	12
E4237	8mm	50.0mm	12
E4238	10mm	50.0mm	12

3/8"Dr. BITS SOCKETS TORX



- S2 alloy steel. High torque and tenacity.

PART #	SIZE	LENGTH	📦
E4242	T10	50.0mm	12
E4243	T15	50.0mm	12
E4244	T20	50.0mm	12
E4245	T25	50.0mm	12
E4246	T27	50.0mm	12
E4247	T30	50.0mm	12
E4248	T40	50.0mm	12
E4249	T45	50.0mm	12
E4250	T50	50.0mm	12
E4251	T55	50.0mm	12

1/2" DR. BIT SOCKETS TORX



- S2 alloy steel. High torque and tenacity.

PART #	SIZE	LENGTH	📦
E4314	T-30	50.0mm	6
E4315	T-40	50.0mm	6
E4316	T-45	50.0mm	6
E4317	T-50	50.0mm	6
E4343	T-27	100.0mm	6
E4344	T-30	100.0mm	6
E4345	T-40	100.0mm	6
E4346	T-45	100.0mm	6
E4347	T-50	100.0mm	6
E4348	T-55	100.0mm	6

1/2" DR. BIT SOCKETS HEX



- S2 alloy steel. High torque and tenacity.

PART #	SIZE	LENGTH	📦
E4322	5mm	50.0mm	12
E4323	6mm	50.0mm	12
E4324	7mm	50.0mm	12
E4325	8mm	50.0mm	12
E4326	10mm	50.0mm	12
E4327	12mm	50.0mm	12
E4328	14mm	50.0mm	12
E4329	17mm	50.0mm	12
E4352	5mm	100.0mm	12
E4353	6mm	100.0mm	12
E4354	7mm	100.0mm	12
E4355	8mm	100.0mm	12
E4356	10mm	100.0mm	12
E4357	12mm	100.0mm	12
E4358	14mm	100.0mm	12

1/2" DR. BIT SOCKETS SPLINE



- S2 alloy steel. High torque and tenacity.

PART #	SIZE	LENGTH	📦
E4362	M-6	100.0mm	12
E4363	M-8	100.0mm	12
E4364	M-10	100.0mm	12
E4365	M-12	100.0mm	12

3/8"Dr. ANTI SKID SOCKET



- Made of Cr-Mo, full polished
- Patent head, can remove hexagonal worn bolt and nut
- Produced upon impact socket standard, can be used by air tools

PART #	SIZE	LENGTH	📦
E3008	8mm	28mm	12
E3009	9mm	28mm	12
E3010	10mm	28mm	12
E3011	11mm	28mm	12
E3012	12mm	28mm	12
E3013	13mm	28mm	12
E3014	14mm	28mm	12
E3015	15mm	28mm	12
E3016	16mm	28mm	12
E3017	17mm	30mm	12
E3018	18mm	30mm	12
E3019	19mm	30mm	12

1/2" Dr. ANTI SKID IMPACT SOCKET



- Made of Cr-Mo, full polished
- Patent head, can remove hexagonal worn bolt and nut
- Produced upon impact socket standard, can be used by air tools

PART #	SIZE	LENGTH	📦
E3030	10mm	35mm	12
E3031	11mm	35mm	12
E3032	12mm	35mm	12
E3033	13mm	35mm	12
E3034	14mm	35mm	12
E3035	15mm	35mm	12
E3036	16mm	35mm	12
E3037	17mm	37mm	12
E3038	18mm	37mm	12
E3039	19mm	37mm	12
E3041	21mm	37mm	12
E3044	24mm	38mm	12

1/2"DR. BIT SOCKETS SPLINE



- Bits made of S2, treat treated, high torque

PART #	SIZE	LENGTH	📦
E4368	M-10	120.0mm	12
E4369	M-12	140.0mm	12

1/2"DR. BIT SOCKETS HEX



- Bits made of S2, treat treated, high torque

PART #	SIZE	LENGTH	📦
E4372	5mm	180.0mm	12
E4375	6mm	140.0mm	12
E4373	6mm	250.0mm	12
E4376	10mm	140.0mm	12

3/8" DELUXE CROWSFOOT WRENCH SET



- Suitable for: 10,11,12,13,14,15,16,17,18,19mm
- Made of Cr-Mo, can be used to remove nut of oil pipe and air-conditioning compressor

PART #	DRIVER	CONTENTS	📦
E0774	3/8"	10PCS	6

6.3mm Dr. FLEXIBLE EXTENSION BAR



- Made of 50BV30#Cr-V
- Meet ANSI B1007.10M-1996, DIN 3123-1976

PART #	SIZE	LENGTH	📦
E3211	6.3mm	150.0mm	12

BITS ADAPTER



- Drop-froged 50BV30#Cr-V
- Meet and exceed ANSI B107.10M-1996,DIN 3123-1976

PART #	DRIVER	MALE	📦
E4538	1/2"	5/16"	12

5

WRENCHS



11PC.DOUBLE BOX END WRENCH SET



5-Double Box End Wrench Set 5.5x7, 6x7, 8x10, 10x12, 11x13mm
6-Double Box End Wrench Set 12x14, 14x17, 17x19, 19x21, 22x24, 24x27mm
• Drop-forged Cr-V steel, full polished.
• Meet ANSI.

PART #	CONTENTS	📦
E1532	11PCS	24

14PC.COMB. WRENCH SET



7-Raised panel combination wrench 3/8", 7/16", 1/2", 9/16", 5/8", 11/16", 3/4"
7-Raised panel combination wrnch13/16", 7/8", 15/16", 1", 1-1/16", 1-1/8", 1-1/4"
• Premium grade drop-forged carbon steel.
• Meet and exceed ANSI B107.9M-1994, DIN899-1980.

PART #	CONTENTS	ΔΔΔ	📦
E1515	14PCS	4.1kg	6

9PC.COMB WRENCH SET



9-Combination Wrench Set 8, 10, 11, 12, 13, 14, 15, 17, 19mm
• Drop-forged Cr-V steel, full polished.
• Meet ANSI.

PART #	CONTENTS	📦
E1527	9PCS	6

14PC.COMB WRENCH SET



14-Combination Wrench Set 8, 9, 10, 11, 12, 13, 14, 15, 16, 17, 18, 19, 22, 24mm
• Drop-forged Cr-V steel, full polished.
• Meet ANSI.

PART #	CONTENTS	📦
E1529	14PCS	12

13PC.COMB. WRENCH SET



13-Raised panel comb. wrench 8, 9, 10, 11, 12, 13, 14, 15, 16, 17, 18, 19, 22mm
• Premium grade drop-forged carbon steel.
• Meet and exceed ANSI B107.9M-1994, DIN899-1980.

PART #	CONTENTS	ΔΔΔ	📦
E1512	13PCS	1.58kg	12

11PC.COMB WRENCH SET



11-Combination Wrench Set 8, 9, 10, 11, 12, 13, 14, 15, 17, 19, 22mm
• Drop-forged Cr-V steel, full polished.
• Meet ANSI.

PART #	CONTENTS	📦
E1528	11PCS	6

23PC.COMB WRENCH SET



23-Combination Wrench Set 5.5, 6, 7, 8, 9, 10, 11, 12, 13, 14, 15, 16, 17, 18, 19, 20, 21, 22, 23, 24, 27, 30, 32mm
• Drop-forged Cr-V steel, full polished.
• Meet ANSI.

PART #	CONTENTS	📦
E1530	23PCS	4

21PC.COMB. WRENCH SET



10-Raised panel comb. wrench6, 7, 8, 9, 10, 11, 12, 13, 14, 15mm
11-Raised panel comb. wrench16, 17, 18, 19, 20, 21, 22, 24, 27, 30, 32mm
• Premium grade drop-forged carbon steel.
• Meet and exceed ANSI B107.9M-1994, DIN899-1980.

PART #	CONTENTS	ΔΔΔ	📦
E1513	21PCS	4.63kg	4

8PC.COMB WRENCH SET



8-Combination Wrench Set 6, 8, 10, 12, 14, 17, 19, 24mm
• Drop-forged Cr-V steel, full polished.
• Meet ANSI.

PART #	CONTENTS	📦
E1516	8PCS	6

12PC.OPEN END WRENCH SET



6-Open End wrench 6", 7", 8", 10", 12", 14", 17mm
6-Open End wrench 16", 17", 19", 21", 22", 24", 27", 30mm
• Drop-forged Cr-V steel, full polished.
• Meet ANSI.

PART #	CONTENTS	📦
E1517	12PCS	6

10PC.OPEN END WRENCH SET



5-Open End wrench6", 7", 8", 10", 11", 13", 14", 17mm
5-Open End wrench17", 19", 21", 23", 24", 27", 30mm
• Drop-forged Cr-V steel, full polished.
• Meet ANSI.

PART #	CONTENTS	📦
E1533	10PCS	6

7PC.COMB.WRENCH SET



- 7-Raised panel combination wrench 8,10,12,13,14,17,19mm
- Premium grade drop-forged carbon steel.
- Meet and exceed ANSI B107.9M-1994, DIN899-1980.

PART #	CONTENTS	ΔTΔ	📦
E1511	7PCS	0.73kg	24

10PC.OPEN END WRENCH SET



- 5-Open end wrench 6x7,8x9,10x11,12x13,14x15mm
- 5-Open end wrench 16x17,18x19,20x22,21x23,24x27mm
- Premium grade drop-forged carbon steel. Raised panel.
- Meet and exceed ANSI B107.9M-1994, DIN899-1980.

PART #	CONTENTS	ΔTΔ	📦
E1525	10PCS	1.38kg	12

9PC.DOUBLE BOX END WRENCH SET



- 5-Double box end wrench 6X7,8X9,10X11,12X13,14X15mm
- 4-Double box end wrench 17X19,21X23,22X24,24X27mm
- Drop-forged chrome vanadium. 75o.
- Meet and exceed ANSI B107.9M-1994, DIN899-1980.

PART #	CONTENTS	ΔTΔ	📦
E1526	9PCS	2.33kg	6

10PC.DOUBLE BOX END WRENCH SET



- 5-Double box end wrench 6*7,8*10,11*13,12*14,14*17mm
- 5-Double box end wrench 17*19,21*23,22*24,24*27,27*30mm
- Drop-forged Cr-V steel, full polished.
- Meet ANSI.

PART #	CONTENTS	ΔTΔ	📦
E1535	10PCS		6

4PC.DOUBLE OPEN END WRENCH SET



4-Full polished double open end wrench 8x10,11x13,12x14,17x19mm

- Drop-forged Cr-V steel, full polished.
- Meet ANSI.

PART #	CONTENTS	ΔTΔ	📦
E1538	4PCS	0.5KG	1

6PC.DOUBLE OPEN END WRENCH SET



6-Full polished double open end wrench 6x7,8x10,11x13,12x14,17x19,21x23mm

- Drop-forged Cr-V steel, full polished.
- Meet ANSI.

PART #	CONTENTS	ΔTΔ	📦
E1539	6PCS	0.8KG	1

8PC.DOUBLE OPEN END WRENCH SET



8-Full polished double open end wrench 5.5x7,8x10,10x12,12x14,14x17,17x19,19x22,22x24mm

- Drop-forged Cr-V steel, full polished.
- Meet ANSI.

PART #	CONTENTS	ΔTΔ	📦
E1540	8PCS	1.1KG	1

10PC.DOUBLE OPEN END WRENCH SET



10-Full polished double open end wrench 5.5x7,8x10,9x11,10x12,12x14,14x17,17x19,19x22,24x27,30x32mm

- Drop-forged Cr-V steel, full polished
- Meet ANSI

PART #	CONTENTS	ΔTΔ	📦
E1541	10PCS	1.9KG	1

13PC.DOUBLE OPEN END WRENCH SET



13-Full polished double open end wrench 6x7,8x10,10x12,11x13,12x14,14x17,17x19,19x21,21x23,22x24,23x26,24x27,30x32mm

- Drop-forged Cr-V steel, full polished.
- Meet ANSI.

PART #	CONTENTS	ΔTΔ	📦
E1542	13PCS	3KG	1

11PC.DOUBLE BOX END WRENCH SET



11-Full polished double box end wrench 8x10,10x12,11x13,12x14,14x17,17x19,19x21,21x23,22x24,23x26,24x27mm

- Drop-forged Cr-V steel, full polished, 45°
- Meet ANSI.

PART #	CONTENTS	ΔTΔ	📦
E1548	11PCS	2.6KG	1

6PC.DOUBLE BOX END WRENCH SET



6-Full polished double box end wrench 8x10,11x13,12x14,17x19,21x23,22x24mm

- Drop-forged Cr-V steel, full polished, 45°
- Meet ANSI.

PART #	CONTENTS	ΔTΔ	📦
E1545	6PCS	1.3KG	1

8PC.DOUBLE BOX END WRENCH SET



8-Full polished double box end wrench 5.5x7,8x10,9x11,12x14,14x17,17x19,19x22,24x27mm

- Drop-forged Cr-V steel, full polished, 45°
- Meet ANSI.

PART #	CONTENTS	ΔTΔ	📦
E1546	8PCS	1.4KG	1

10PC.DOUBLE BOX END WRENCH SET



10-Full polished double box end wrench 5.5x7,8x10,9x11,10x12,12x14,14x17,17x19,19x22,24x27,30x32mm

- Drop-forged Cr-V steel, full polished, 45°
- Meet ANSI.

PART #	CONTENTS	ΔTΔ	📦
E1547	10PCS	2.1KG	1

10PC.COMB. WRENCH SET



- 10-Raised panel combination wrench 6,8,10,11,12,13,14,15,16,17mm
- Premium grade drop-forged carbon steel.
- Meet and exceed ANSI B107.9M-1994, DIN899-1980.

PART #	CONTENTS	ΔTΔ	📦
E1521	10PCS	0.83kg	6

5PC.GEARTECH WRENCH SET



- 5-Full polished combination wrench 8,10,12,13,14mm
- Drop-forged Cr-V steel, full polished

PART #	CONTENTS	ΔTΔ	📦
E2501	5PCS	0.51kg	6

5PC.GEARTECH WRENCH SET



- 5-Geartech combination wrench 10,12,13,14,15mm
- Drop-forged Cr-V steel, full polished

PART #	CONTENTS	ΔTΔ	📦
E2502	5PCS	0.6kg	6

7PC.GEARTECH WRENCH SET



- 7-Raised panel combination wrench 8,10,12,13,14,15,18mm
- Drop-forged Cr-V steel, full polished

PART #	CONTENTS	ΔTΔ	📦
E2503	7PCS	0.96kg	6

5PC.MINI RATCHET



- Drop-forged Cr-V, 72 teeth

PART #	CONTENTS	ΔTΔ	📦
E2505	5PCS	0.17kg	6

12PC.GEARTECH WRENCH SET



- 8-Geartech combination wrench 8,10,12,13,14,15,17,19mm
- 1-Bit adapter
- 3-Socket adapter 1/4"x3/8", 3/8"x1/2", 1/2"x3/4"

PART #	CONTENTS	ΔTΔ	📦
E2504	12PCS	1.5kg	6

UNIVERSAL WRENCH SET



- 1-Universal wrench 9-14MM,15-22MM
- 1-Universal wrench 23-32MM
- Durable and easy to use.
- To be used on the pipe's diameter 9-22mm,15-32mm without any size adjustment.

PART #	CONTENTS	ΔΔ	📦
E1519	2PCS	0.53kg	6

QUICK RELEASE ADAPTER



- Adapt socket together with quick-release ratchet. Cr-V.
- Quick-release capability.

PART #	SIZE	LENGTH	📦
E2591	3/8"	17.5mm	12
E2592	1/2"	22.5mm	12
E2593	3/4"	29.5mm	12

BITS ADAPTER



- Adapt sockets together with quick-release ratchet. Cr-V

PART #	SIZE	LENGTH	📦
E2594	1/4"x3/8"	19.5mm	12

QUICK RELEASE ADAPTER



- Adapt sockets together with quick-release ratchet. Cr-V

PART #	SIZE	LENGTH	📦
E2595	1/4"x3/8"	21.5mm	12
E2596	3/8"x1/2"	26.5mm	12
E2597	1/2"x3/4"	29.5mm	12

ADJUSTABLE WRENCH



- Heavy duty design and reinforced handle.
- Full polished and comfortable to use.
- With scale.
- Carbon steel

PART #	SIZE	MAX.OPENING	LENGTH	📦
E2020	4"	16.0mm	99.0mm	6
E2021	6"	20.0mm	153.0mm	6
E2022	8"	25.0mm	204.0mm	6
E2023	10"	30.0mm	257.0mm	6
E2024	12"	35.0mm	305.0mm	4
E2026	15"	45.0mm	380.0mm	4
E2027	18"	55.0mm	453.0mm	2
E2028	24"	65.0mm	602.0mm	1

ADJUSTABLE WRENCH



- Drop-forged Cr-V.
- Heavy duty design and reinforced handle.
- Full polished and comfortable to use.
- Accurately adjust the spacing with scale.

PART #	SIZE	Max.Opening	LENGTH	📦
E2031	6"	20.0mm	153.0mm	6
E2032	8"	25.0mm	204.0mm	6
E2033	10"	30.0mm	257.0mm	6
E2034	12"	35.0mm	305.0mm	4

ADJUSTABLE WRENCH



- Cr-V
- Heavy duty design and reinforced handle.
- Full polished and comfortable to use.
- With scale. TPR rubber & plastic handle, comfortable to use.

PART #	SIZE	MAX.OPENING	LENGTH	📦
E2041	6"	24.0mm	153.0mm	6
E2042	8"	30.0mm	204.0mm	6
E2043	10"	35.0mm	257.0mm	6
E2044	12"	41.0mm	305.0mm	4

ADJUSTABLE WRENCH



- Plastic-coated handle. Nonskid treatment Carbon Steel.
- With scale.

PART #	SIZE	Max.Opening	LENGTH	📦
E2011	6"	20.0mm	153.0mm	6
E2012	8"	25.0mm	204.0mm	6
E2013	10"	30.0mm	257.0mm	6
E2014	12"	35.0mm	305.0mm	4



DOUBLE BOX GEARTECH WRENCH



- Drop-forged chrome vanadium, 72 teeth design.
- 5 degree enough to move a nut.
- Applied to narrow space; quick release.

PART #	SIZE	LENGTH	📦
E2561	8x10mm	128.0mm	6
E2562	10x11mm	150.0mm	6
E2563	12x13mm	170.0mm	6
E2564	14x15mm	190.0mm	6
E2565	16x18mm	230.0mm	6
E2566	17x19mm	230.0mm	6
E2567	22x24mm	290.0mm	6

GEARTECH WRENCH



- Drop-forged chrome vanadium, 72 teeth design.
- Only need 5 angle of movement to turn a nut.
- Applied to narrow space; quick release.

PART #	SIZE	LENGTH	📦
E2509	6mm	136.0mm	6
E2510	7mm	136.0mm	6
E2511	8mm	136.0mm	6
E2512	9mm	143.0mm	6
E2513	10mm	160.0mm	6
E2514	11mm	168.0mm	6
E2515	12mm	174.0mm	6
E2516	13mm	180.0mm	6
E2517	14mm	193.0mm	6
E2518	15mm	200.0mm	6
E2519	16mm	216.0mm	6
E2520	17mm	233.0mm	6
E2521	18mm	239.0mm	6
E2522	19mm	250.0mm	6
E2523	21mm	285.0mm	6
E2524	22mm	285.0mm	6
E2525	24mm	325.0mm	6
E2527	27mm	359.0mm	4
E2528	30mm	425.0mm	4
E2529	32mm	425.0mm	4

REVERSIBLE GEARTECH WRENCH



- Drop-forged chrome vanadium, 72 teeth design.
- Only need 5 angle of movement to turn a nut.
- Applied to narrow space; quick release.

PART #	SIZE	LENGTH	📦
E2531	8mm	135.0mm	6
E2533	10mm	158.0mm	6
E2534	12mm	173.0mm	6
E2536	13mm	179.0mm	6
E2537	14mm	189.0mm	6
E2539	16mm	215.0mm	6
E2540	17mm	232.0mm	6
E2542	19mm	247.0mm	6
E2544	22mm	285.0mm	6
E2546	24mm	325.0mm	6

COMBINAION WRENCH



- Drop-forged chrome vanadium, 72 teeth design.
- Only need 5 angle of movement to turn a nut.
- Applied to narrow space; quick release.

PART #	SIZE	TORX	LENGTH	📦
E2550	8mm	E10	136.0mm	6
E2551	10mm	E12	160.0mm	6
E2552	11mm	E14	168.0mm	6
E2553	12mm		174.0mm	6
E2554	13mm	E16	180.0mm	6
E2555	14mm	E18	193.0mm	6
E2557	16mm	E20	216.0mm	6
E2558	17mm	E22	233.0mm	6
E2560	19mm	E24	250.0mm	6

STUBBY DOUBLE BOX GEARTECH WRENCH



- Drop-forged Cr-V, 72 teeth .
- 5 angle of movement to move a nut.
- Head movement in 180 degree.

PART #	SIZE	LENGTH	📦
E2571	8x10mm	125.0mm	6
E2572	12x13mm	146.0mm	6
E2573	14x15mm	163.0mm	6
E2574	16x18mm	182.0mm	6
E2575	17x19mm	185.0mm	6

OPEN END WRENCH



- Made of Carbon Steel.
- A Type, Meet ANSI.

PART #	SIZE	LENGTH	📦
E2352	32x36mm	315.0mm	2
E2353	36x41mm	340.0mm	2
E2354	41x46mm	380.0mm	2

COMBINATION WRENCH

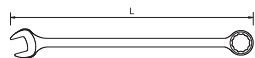

- Drop-forged Cr-V, 72 teeth .
- 5 angle of movement to move a nut.
- Head movement in 180 degree.

PART #	SIZE	LENGTH	🔩
E2578	8mm	136.0mm	6
E2579	10mm	160.0mm	6
E2580	12mm	174.0mm	6
E2581	13mm	180.0mm	6
E2582	14mm	193.0mm	6
E2583	16mm	216.0mm	6
E2584	17mm	233.0mm	6
E2586	19mm	250.0mm	6
E2587	22mm	285.0mm	6
E2588	24mm	325.0mm	6



FLARE NUT WRENCH

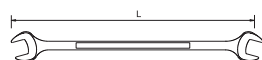

- Drop-forged, Cr-V steel. Full polished.

PART #	SIZE	LENGTH	🔩
E2471	8X10mm	145.0mm	12
E2472	9X11mm	145.0mm	6
E2473	10X12mm	155.0mm	6
E2474	13X14mm	175.0mm	6

COMBINATION WRENCH

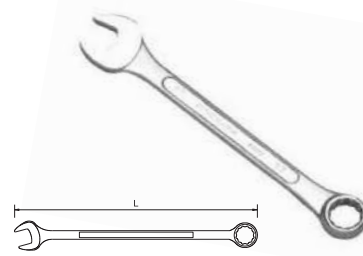

- Raised Panel.
- Made of Carbon Steel.
- Meet ANSI.

PART #	SIZE	LENGTH	🔩
E2206	6mm	93.0mm	12
E2207	7mm	98.0mm	12
E2208	8mm	103.0mm	12
E2209	9mm	116.0mm	12
E2210	10mm	123.0mm	12
E2211	11mm	131.0mm	12
E2212	12mm	143.0mm	12
E2213	13mm	147.0mm	12
E2214	14mm	168.0mm	12
E2215	15mm	189.0mm	12
E2216	16mm	196.0mm	12
E2217	17mm	207.0mm	12
E2218	18mm	220.0mm	12
E2219	19mm	230.0mm	12
E2220	20mm	230.0mm	12
E2221	21mm	242.0mm	6
E2222	22mm	260.0mm	6
E2224	24mm	309.0mm	6
E2227	27mm	358.0mm	4
E2230	30mm	380.0mm	4
E2232	32mm	418.0mm	4

OPEN END WRENCH



- Made of carbon steel.
- Meet and exceed ANSI.

PART #	SIZE	LENGTH	🔩
E2370	5.5x7mm	125mm	12
E2371	6x7mm	125mm	12
E2372	8x10mm	135mm	12
E2373	9x11mm	146mm	12
E2374	10x12mm	146mm	12
E2375	11x13mm	170mm	12
E2376	12x14mm	170mm	12
E2377	13x15mm	178mm	12
E2378	13x16mm	185mm	12
E2379	13x17mm	185mm	12
E2380	14x17mm	185mm	12
E2381	16x18mm	195mm	12
E2382	17x19mm	225mm	12
E2383	19x21mm	240mm	12
E2384	19x22mm	240mm	12
E2385	21x23mm	255mm	6
E2386	22x24mm	270mm	6
E2387	23x26mm	280mm	6
E2388	24x27mm	280mm	6
E2389	27x30mm	305mm	6
E2390	30x32mm	330mm	6

DOUBLE BOX END WRENCH

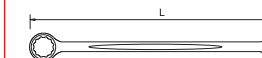

- German-type raised panel wrench.
- Drop-forged Cr-V steel. Meet ANSI
- 75° Angle Design, Applied to Narrow Space.

PART #	SIZE	LENGTH	🔩
E2400	5.5x7mm	170.0mm	12
E2401	6x7mm	170.0mm	12
E2402	8x9mm	182.0mm	12
E2403	8x10mm	182.0mm	12
E2404	10x11mm	193.0mm	12
E2406	10x12mm	197.0mm	12
E2408	11x13mm	212.0mm	12
E2405	12x13mm	212.0mm	12
E2409	12x14mm	212.0mm	12
E2407	14X15mm	227.0mm	12
E2411	14x17mm	227.0mm	12
E2410	17x19mm	265.0mm	6
E2412	19x21mm	310.0mm	6
E2413	21x23mm	310.0mm	6
E2414	22X24mm	310.0mm	6
E2415	23x26mm	330.0mm	6
E2416	24x27mm	330.0mm	6
E2418	30x32mm	372.0mm	6

COMBINATION WRENCH

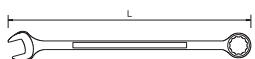

- JB Type, Made of carbon steel. Meet and exceed ANSI.

PART #	SIZE	LENGTH	🔩
E2234	34mm	433.0mm	4
E2236	36mm	467.0mm	4
E2241	41mm	505.0mm	4
E2246	46mm	540.0mm	2
E2250	50mm	608.0mm	2
E2252	55mm	613.0mm	2
E2254	60mm	665.0mm	2
E2256	65mm	678.0mm	2

DOUBLE BOX END WRENCH

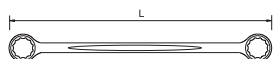

- Made of Cr-V. Meet and exceed ANSI.
- Full polished. Rust-proof.
- 45°

PART #	SIZE	LENGTH	🔩
E2453	32x36mm	408.0mm	2
E2454	36x41mm	456.0mm	2
E2455	41x46mm	491.0mm	2

COMBINATION WRENCH

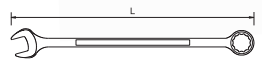

- Drop-forged, Cr-V steel. Full polished.
- Meet ANSI.

PART #	SIZE	LENGTH	🔩
E2605	5.5mm	124.0mm	12
E2606	6mm	124.0mm	12
E2607	7mm	129.0mm	12
E2608	8mm	136.0mm	12
E2609	9mm	149.0mm	12
E2610	10mm	161.0mm	12
E2611	11mm	168.0mm	12
E2612	12mm	174.0mm	12
E2613	13mm	180.0mm	12
E2614	14mm	190.0mm	12
E2615	15mm	200.0mm	12
E2616	16mm	207.0mm	12
E2617	17mm	227.0mm	12
E2618	18mm	235.0mm	12
E2619	19mm	250.0mm	12
E2620	20mm	260.0mm	6
E2621	21mm	271.0mm	6
E2622	22mm	290.0mm	6
E2623	23mm	295.0mm	6
E2624	24mm	317.0mm	6
E2625	25mm	335.0mm	6
E2627	27mm	356.0mm	4
E2630	30mm	385.0mm	4
E2632	32mm	420.0mm	4

OPEN END WRENCH

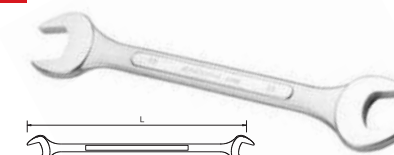

- Raised Panel.
- Made of Carbon Steel.
- Meet ANSI.

PART #	SIZE	LENGTH	🔩
E2330	5.5x7mm	102.0mm	12
E2331	6x7mm	102.0mm	12
E2332	8x9mm	110.0mm	12
E2358	8x10mm	110.0mm	12
E2333	10x11mm	126.0mm	12
E2343	10x12mm	126.0mm	12
E2344	11x13mm	135.0mm	12
E2334	12x13mm	152.0mm	12
E2345	12x14mm	152.0mm	12
E2335	14x15mm	157.0mm	12
E2357	13x15mm	157.0mm	12
E2342	13x16mm	157.0mm	12
E2346	14x17mm	157.0mm	12
E2336	16x17mm	180.0mm	12
E2351	16x18mm	180.0mm	12
E2347	17x19mm	190.0mm	12
E2337	18x19mm	190.0mm	12
E2359	18x21mm	212.0mm	12
E2348	19x21mm	212.0mm	12
E2360	19x22mm	212.0mm	12
E2338	20x22mm	212.0mm	12
E2339	21x23mm	212.0mm	6
E2340	22x24mm	212.0mm	6
E2349	23x26mm	258.0mm	6
E2341	24x27mm	258.0mm	6
E2362	27x30mm	340.0mm	6
E2350	30x32mm	340.0mm	6

DOUBLE BOX END WRENCH



- Made of Cr-V. Meet and exceed ANSI.
- Full polished. Rust-proof.
- 45° Angle Design

PART #	SIZE	LENGTH	🔩
E2430	5.5x7mm	171.8mm	12
E2431	6x7mm	175.8mm	12
E2433	8x10mm	188.4mm	12
E2434	9x11mm	188.4mm	12
E2435	10x12mm	198.5mm	12
E2436	11x13mm	223.8mm	12
E2438	12x14mm	223.8mm	12
E2441	14x17mm	240.0mm	12
E2437	16x18mm	256.1mm	6
E2439	13x15mm	223.8mm	12
E2440	13x16mm	223.8mm	6
E2442	17x19mm	256.1mm	6
E2444	19x21mm	276.2mm	6
E2445	19x22mm	276.2mm	6
E2446	21x23mm	326.0mm	6
E2447	22x24mm	326.0mm	6
E2449	23x26mm	367.0mm	6
E2450	24x27mm	367.0mm	6
E2451	30x32mm	415.0mm	6

CONSTRUCTION WRENCH



- Made of Cr-V. Drop-forged.
- Rust prevention treatment

PART #	SIZE	LENGTH	🔩
E2711	10x12mm	250.0mm	4
E2713	12x14mm	250.0mm	4
E2714	14x17mm	250.0mm	4
E2715	17x19mm	290.0mm	4
E2717	19x21mm	290.0mm	4
E2718	19x22mm	290.0mm	4
E2719	19x24mm	290.0mm	4
E2721	22x24mm	290.0mm	2
E2722	24x27mm	370.0mm	2
E2723	24x30mm	370.0mm	2
E2724	30x32mm	370.0mm	2
E2725	32x36mm	416.0mm	2
E2726	36x41mm	416.0mm	2

SLOGGING RING WRENCH



- Made in CR-V
- Phosphate coated and rust prevention treatment.

PART #	SIZE	LENGTH	
E2802	27mm	180.0mm	1
E2803	30mm	190.0mm	1
E2804	32mm	190.0mm	1
E2805	36mm	205.0mm	1
E2806	41mm	230.0mm	1
E2807	46mm	240.0mm	1
E2808	50mm	255.0mm	1
E2809	55mm	270.0mm	1
E2810	60mm	280.0mm	1
E2811	65mm	300.0mm	1
E2812	70mm	300.0mm	1
E2813	75mm	330.0mm	1
E2814	80mm	360.0mm	1
E2815	85mm	360.0mm	1
E2816	90mm	390.0mm	1
E2817	95mm	390.0mm	1
E2818	100mm	420.0mm	1
E2819	105mm	420.0mm	1
E2820	110mm	450.0mm	1
E2821	115mm	450.0mm	1
E2822	120mm	480.0mm	1

HEAVY-DUTY OPEN-END WRENCHES



- Made in CR-V
- Phosphate coated and rust prevention treatment.

PART #	SIZE	LENGTH	
E2941	21mm	193.0mm	1
E2942	24mm	217.0mm	1
E2943	27mm	239.0mm	1
E2944	30mm	263.0mm	1
E2945	32mm	275.0mm	1
E2946	34mm	290.0mm	1
E2947	36mm	305.0mm	1
E2948	41mm	344.0mm	1
E2949	46mm	380.0mm	1
E2950	50mm	413.0mm	1
E2951	55mm	459.0mm	1
E2952	60mm	494.0mm	1
E2953	65mm	528.0mm	1
E2954	70mm	572.0mm	1

SLOGGING OPEN WRENCH



- Made in CR-V
- Phosphate coated and rust prevention treatment.

PART #	SIZE	LENGTH	
E2905	36mm	205.0mm	1
E2906	41mm	230.0mm	1
E2907	46mm	240.0mm	1
E2908	50mm	255.0mm	1
E2909	55mm	270.0mm	1
E2910	60mm	280.0mm	1
E2911	65mm	300.0mm	1
E2912	70mm	300.0mm	1
E2913	75mm	330.0mm	1
E2914	80mm	360.0mm	1
E2915	85mm	360.0mm	1
E2916	90mm	390.0mm	1
E2917	95mm	390.0mm	1
E2918	100mm	420.0mm	1
E2919	105mm	420.0mm	1

HOOK WRENCH



- Made in CR-V
- Phosphate coated and rust prevention treatment.

PART #	SIZE	LENGTH	
E2982	22-50mm	145.0mm	1
E2983	32-75mm	178.0mm	1
E2984	50-120mm	247.0mm	1

ENDURA®
A Textron Company



6

SCREWDRIVER & BITS

SCREWDRIVER SET



- 3-Bits 3.0 5.0 6.0mm
- 3-Bits PH1 PH2 PH0
- 2-Bits T15 T20
- 2-Bits PZ1 PZ2
- 1-Bits 2.0mm

PART #	CONTENTS	ΔΔ	📦
T6106	11PCS		6

15PC.SCREWDRIVER SET



- 3-1/4" Dr. 25mm Bits slotted 4,5,5,6,5mm
- 3-1/4" Dr. 25mm Bits phillips #1,#2,#3
- 4-1/4" Dr. 25mm Bits Hex 3,4,5,6mm
- 3-1/4" Dr. 25mm Bits Torx T10,T15,T20
- 1-1/4" Dr. 25mm Bit Adapter
- 1-Spinner Handle

• Bits made of premium grade S2, rust proof.

PART #	CONTENTS	ΔΔ	📦
E1113	15PCS	0.22kg	6

8PC.SCREWDRIVER SET



- 4-Screwdriver slotted 3x75,5x100,6x38,6x150mm
- 4-Screwdriver Phillips #0x75,#1x100,#2x38,#2x150mm
- Blade made of Cr - V.

PART #	CONTENTS	ΔΔ	📦
E1164	8PCS	0.68kg	6

8PC.SCREWDRIVER SET



- 4-Screwdriver slotted 3x75,5x75,6x38,6x150mm
- 4-Screwdriver phillips #0x75,#1x100,#2x38,#2x150mm
- Blade made of Cr-Mo, high torque and tenacity.

PART #	CONTENTS	ΔΔ	📦
E1166	8PCS	0.58kg	6

8PC.SCREWDRIVER SET



- 8-Screwdriver Torx T8,T10,T15,T20,T25,T27,T30,T40
- Blade made of Cr - V.

PART #	CONTENTS	ΔΔ	📦
E1167	8PCS	0.58kg	6

4PC.MINI SCREWDRIVER SET



- 1-Mini screwdriver handle
- 3-Blades T5-T6,T7-T8,T9-T10
- Blade made of Cr-V

PART #	CONTENTS	ΔΔ	📦
E1116	4PCS	0.22kg	12

8PC.SCREWDRIVER SET



- 4-Screwdriver slotted 3x75,5x75,6x38,6x150mm
- 4-Screwdriver phillips #0x75,#1x100,#2x38,#2x150mm
- Blade made of Cr - Mo, high torque and tenacity.

PART #	CONTENTS	ΔΔ	📦
E1172	8PCS	0.58kg	6

6PC.MINI SCREWDRIVER SET



- 4-Mini screwdriver slotted 1.4x40mm,2.0x40mm,2.4x40mm 3.0x40mm
- 2-Screwdriver phillips PH00x40mm,PH0x40mm
- Blade made of Cr-V, high torque and tenacity.

PART #	CONTENTS	ΔΔ	📦
E1114	6PCS	0.58kg	6

4PC.MINI SCREWDRIVER SET



- 1-Mini screwdriver handle
- 3-Blades 2.0, PH00, 2.4, PH0, T6-T8
- Blade made of Cr-V

PART #	CONTENTS	ΔΔ	📦
E1115	4PCS	0.22kg	12

5/16"DR. LONG BITS



- Suitable for car engine
- Premium grade steel, good torque and hardness

PART #	SIZE	LENGTH	📦
T6865	PH2	80.0mm	12
T6866	PH2	150.0mm	12
T6864	PH2	200.0mm	12

6PC.MINI SCREWDRIVER SET



- 2-Mini screwdriver 2.0x40mm,2.4x40mm
- 2-Mini screwdriver PH00x40mm,PH0x40mm
- 2-Mini screwdriver T6x40mm,T8x40mm
- Blade made of Cr-Mo, high torque and tenacity.

PART #	CONTENTS	ΔΔ	📦
E1117	6PCS	0.15kg	6

7PC.MINI SCREWDRIVER SET



- 1-Mini screwdriver handle
- 3-Blades T5-T8,T6-T10,T4-H2.0
- 3-Blades T7-H1.5,PH0-2.5,PH00-1.5
- Blade made of Cr-V, convenient to use.

PART #	CONTENTS	ΔΔ	📦
E1118	7PCS	0.14kg	12

31PC. MINI SCREWDRIVER SET



- 9- T4,T5,T6,T7,T8,T9,T10,T15,T20
- 7- 1.0,1.5,2.0,2.5,3.0,3.5,4.0mm
- 4- NO.000,NO.00,NO.0,NO.1
- 2- NO.0,NO.1
- 8- 0.7,0.9,1.3,1.5,2.0,2.5,3.0,4.0mm

PART #	CONTENTS	📦
E6744	31PCS	12

6PC.CLOCK AND WATCH SCREWDRIVER SET



- 4-Slotted 1.0,1.4,2.0,2.4mm
- 2-Phillips PH0,PH1

PART #	CONTENTS	📦
E6745	6PCS	12

9PC.MULTI-SCREWDRIVER SET



- 1-changeable Screwdriver Handle
- 3-Screwdriver PH0,PH1,PH2
- 3-Screwdriver 3.2,5,6mm
- 2-Special Screwdriver, Fine Point
- Multi-purpose

PART #	CONTENTS	ΔΔ	📦
E1161	9PCS	0.3kg	6

2PC.SCREWDRIVER SET



- 1-Rubber&plastic screwdriver grip.
- 1-Blades slotted 5.5mmx150mm,PH2x150MM

PART #	CONTENTS	ΔΔ	📦
E6742	2PCS	0.135kg	6

SCREWDRIVER SET



- 1-Screwdriver Handle
- 1-Blade 6.0mm PH2

PART #	CONTENTS	📦
T6104	2PCS	6

SCREWDRIVER SET



- 1-Screwdriver Handle
- 2-Blade 4.0mm PH1, 6.0mm PH2

PART #	CONTENTS	📦
T6105	3PCS	6

10PC.AND EXCHANGES SCREWDRIVERS SET



- 10PC-T6,T8,T10,T15,PH00,PH0,PH1,2.0,3.0,5.0mm
- All-purpose, suitable for precise job.

PART #	CONTENTS	📦
T1128	10PCS	12

7PC.RATCHET SCREWDRIVER SET



- 1-Rubber&plastic screwdriver handle.
- 6-1/4" Dr. 25L bit 4,5,5,6,5, #1,#2,#3
- With ratchet design, bi-direction use.
- Bit made of premium grade S2, high torque and tenacity, rust-proof.

PART #	CONTENTS	ΔΔ	📦
E6735	7PCS	0.17kg	6

8PCS RATCHET SCREWDRIVER SET



- TPR handle,comfortable
- Fashion design

PART #	SIZE	CONTENTS	LENGTH	📦
E6705	1/4	8PCS	280.0mm	6

10PC.SCREWDRIVER SET



- 5-Screwdriver slotted 5x75,3x100,5x100,6x150,8x150mm
- 5-Screwdriver phillips 1#x75,0#x100,1#x100,2#x150,3#x150mm
- Box size: 380x260x80mm
- Blade made of Cr-Mo.

PART #	CONTENTS	ΔΔ	📦
E1173	10PCS	0.9kg	6

SCREWDRIVER DISPLAY STAND



- High range organic glass, high transparence
- Display screwdriver and bits for 56pcs
- Special design, normal display casework

MINI SCREWDRIVER SLOTTED



- Blade made of Cr-Mo

PART #	SIZE	LENGTH	📦
E6761	1.4X40mm	130.7mm	12
E6762	2.0X40mm	130.7mm	12
E6763	2.4X40mm	130.7mm	12
E6764	3.0X40mm	130.7mm	12
E6765	2.0X75mm	165.7mm	12
E6766	3.0X100mm	190.7mm	12
E6767	4.0X150mm	240.7mm	12

MINI SCREWDRIVER TORX



- Blade made of Cr-Mo

PART #	SIZE	LENGTH	📦
E6781	T4X40mm	130.7mm	12
E6782	T5X40mm	130.7mm	12
E6783	T6X40mm	130.7mm	12
E6784	T7X40mm	130.7mm	12
E6785	T8X40mm	130.7mm	12
E6786	T9X40mm	130.7mm	12
E6787	T10X40mm	130.7mm	12
E6788	T15X40mm	130.7mm	12

MINI SCREWDRIVER PHILLIPS



- Blade made of Cr-Mo

PART #	SIZE	LENGTH	📦
E6771	PH00x40mm	130.7mm	12
E6772	PH0X40mm	130.7mm	12
E6773	PH0X40mm	130.7mm	12
E6774	PH1X40mm	130.7mm	12
E6775	PH00X75mm	165.7mm	12
E6776	PH0X100mm	190.7mm	12
E6777	PH1X150mm	240.7mm	12

MULTI-SCREWDRIVER



- Made of Cr-V.

PART #	SIZE	Ø	📦
E6746	5.5mmxPH2	5.5mm	12
E6747	PH1xPH2	5.5mm	12
E6748	PH2xPH3	6.0mm	12

SCREWDRIVER PHILLIPS



- Blade made of Cr-V
- PVC handle.

PART #	SIZE	LENGTH	📦
E6221	#0X75mm	155.0mm	12
E6222	#0X100mm	180.0mm	12
E6223	#0X150mm	230.0mm	12
E6224	#0X200mm	280.0mm	12
E6227	#1X75mm	155.0mm	12
E6228	#1X100mm	180.0mm	12
E6229	#1X150mm	230.0mm	12
E6230	#1X200mm	280.0mm	12
E6231	#1X250mm	330.0mm	12
E6233	#2X100mm	190.0mm	12
E6234	#2X150mm	240.0mm	12
E6235	#2X200mm	290.0mm	12
E6236	#2X250mm	340.0mm	12
E6237	#3X150mm	240.0mm	12
E6238	#3X200mm	290.0mm	12

SCREWDRIVER SLOTTED



- Blade made of Cr-V
- PVC handle.

PART #	SIZE	LENGTH	📦
E6201	3X75mm	155.0mm	12
E6202	3X100mm	180.0mm	12
E6203	3X150mm	230.0mm	12
E6204	3X200mm	280.0mm	12
E6207	5X75mm	155.0mm	12
E6208	5X100mm	180.0mm	12
E6209	5X150mm	230.0mm	12
E6210	5X200mm	280.0mm	12
E6211	5X250mm	330.0mm	12
E6213	6X100mm	190.0mm	12
E6214	6X150mm	240.0mm	12
E6215	6X200mm	290.0mm	12
E6216	6X250mm	340.0mm	12
E6217	8X150mm	240.0mm	12
E6218	8X200mm	290.0mm	12

SCREWDRIVER PHILLIPS



- Blade made of Cr-Mo, height torque and tenacity.
- PVC handle.

PART #	SIZE	LENGTH	📦
E6232	#2X38mm	128.0mm	12

SCREWDRIVER SLOTTED



- Blade made of Cr-V
- PVC handle.

PART #	SIZE	LENGTH	📦
E6212	6X38mm	128.0mm	12

SCREWDRIVER PHILIPPS



- Blade made of Cr - Mo, heat treated.
- Two tone TPR rubber & plastic grip, comfortable to use.

PART #	SIZE	LENGTH	📦
E6521	#0x75mm	160.0mm	12
E6522	#0x100mm	185.0mm	12
E6523	#0x150mm	235.0mm	12
E6527	#1x75mm	183.3mm	12
E6528	#1x100mm	208.3mm	12
E6529	#1x150mm	258.3mm	12
E6530	#1x200mm	308.3mm	12
E6532	#2x100mm	215.8mm	12
E6533	#2x150mm	265.8mm	12
E6534	#2x200mm	315.8mm	12
E6535	#2x250mm	365.8mm	12
E6536	#3x150mm	278.2mm	12
E6537	#3x200mm	325.0mm	12

SCREWDRIVER SLOTTED



- Blade made of Cr - Mo, heat treated.
- Two tone TPR rubber & plastic grip, comfortable to use.

PART #	SIZE	LENGTH	📦
E6501	3x75mm	160.0mm	12
E6502	3x100mm	185.0mm	12
E6503	3x150mm	235.0mm	12
E6507	5x75mm	183.3mm	12
E6508	5x100mm	208.3mm	12
E6509	5x150mm	258.3mm	12
E6510	5x200mm	308.3mm	12
E6512	6x100mm	215.8mm	12
E6513	6x150mm	265.8mm	12
E6514	6x200mm	315.0mm	12
E6515	6x250mm	365.8mm	12
E6516	8x150mm	278.0mm	12
E6517	8x200mm	325.0mm	12

SCREWDRIVER WITH STRIKING CAP, PHILLIPS



- Blade made of S2.
- Ergonomic handle.

PART #	SIZE	LENGTH	📦
E6691	#2X100mm	223.0mm	12
E6692	#2X150mm	273.0mm	12
E6693	#3X150mm	273.0mm	12
E6694	#3X200mm	323.0mm	12
E6695	#3X250mm	373.0mm	12

SCREWDRIVER PHILLIPS



- Blade made of Cr - Mo, heat treated.
- Two tone rubber & plastic grip, comfortable to use.

PART #	SIZE	LENGTH	📦
E6531	#2x38mm	101.4mm	12

SCREWDRIVER SLOTTED



- Blade made of Cr - Mo, heat treated.
- Two tone rubber & plastic grip, comfortable to use.

PART #	SIZE	LENGTH	📦
E6511	6x38mm	101.4mm	12

SCREWDRIVER WITH STRIKING CAP, SLOTTED



- Blade made of S2.
- Heavy Rivet for Striking Purpose.

PART #	SIZE	LENGTH	📦
E6681	6X100mm	223.0mm	12
E6682	6X150mm	273.0mm	12
E6683	8X150mm	273.0mm	12
E6684	8X200mm	323.0mm	12
E6685	8X250mm	373.0mm	12

SCREWDRIVER PHILLIPS



- Blade made of Cr - Mo, heat treated.
- Two tone TPR rubber & plastic grip, comfortable to use.

PART #	SIZE	LENGTH	
E6571	#0x50mm	140.0mm	12
E6572	#0x75mm	165.0mm	12
E6573	#0x100mm	190.0mm	12
E6574	#0x125mm	215.0mm	12
E6575	#0x150mm	240.0mm	12
E6582	#1x75mm	165.0mm	12
E6583	#1x100mm	190.0mm	12
E6584	#1x125mm	215.0mm	12
E6585	#1x150mm	240.0mm	12
E6586	#1x200mm	290.0mm	12
E6590	#2x100mm	215.0mm	12
E6591	#2x125mm	240.0mm	12
E6592	#2x150mm	265.0mm	12
E6593	#2x200mm	315.0mm	12
E6597	#3x150mm	265.0mm	12
E6598	#3x200mm	315.0mm	12
E6599	#3x250mm	365.0mm	12
E6600	#3x300mm	415.0mm	12

SCREWDRIVER SLOTTED



- Blade made of Cr - Mo, heat treated and magnetized.
- Two tone rubber & plastic grip, comfortable to use.

PART #	SIZE	LENGTH	
E6541	3x50mm	140.0mm	12
E6542	3x75mm	165.0mm	12
E6543	3x100mm	190.0mm	12
E6544	3x125mm	215.0mm	12
E6545	3x150mm	240.0mm	12
E6552	5x75mm	165.0mm	12
E6553	5x100mm	190.0mm	12
E6554	5x125mm	215.0mm	12
E6555	5x150mm	240.0mm	12
E6556	5x200mm	290.0mm	12
E6560	6x100mm	215.0mm	12
E6561	6x125mm	240.0mm	12
E6562	6x150mm	265.0mm	12
E6563	6x200mm	315.0mm	12
E6567	8x150mm	265.0mm	12
E6568	8x200mm	315.0mm	12
E6569	8x250mm	365.0mm	12
E6570	8x300mm	415.0mm	12

TELECOMMUNICATION SCREWDRIVER PHILLIPS



- Blade made of Cr - Mo, heat treated and magnetized.
- Two tone rubber & plastic grip, comfortable to use.
- Ultra-long blade, suitable for tele-communication maintenance.

PART #	SIZE	LENGTH	
E6371	PH000x150mm	240.0mm	12
E6374	PH00x150mm	240.0mm	12
E6376	PH0x200mm	290.0mm	12
E6377	PH0x250mm	340.0mm	12
E6378	PH0x300mm	390.0mm	12
E6379	PH1x250mm	340.0mm	12
E6380	PH1x300mm	390.0mm	12
E6382	PH2x250mm	365.0mm	12
E6383	PH2x300mm	415.0mm	12
E6384	PH2x350mm	465.0mm	12
E6385	PH2x400mm	515.0mm	12

SCREWDRIVER PHILLIPS



- Blade made of Cr - Mo, heat treated.
- Two tone TPR rubber & plastic grip, comfortable to use.

PART #	SIZE	LENGTH	
E6589	#2X38mm	93.0mm	12

SCREWDRIVER SLOTTED



- Blade made of Cr - Mo, heat treated and magnetized.
- Two tone rubber & plastic grip, comfortable to use.

PART #	SIZE	LENGTH	
E6559	6X38mm	93.0mm	12

TELECOMMUNICATION SCREWDRIVER SLOTTED



- Blade made of Cr - Mo, heat treated and magnetized.
- Two tone rubber & plastic grip, comfortable to use.
- Ultra-long blade, suitable for tele-communication maintenance.

PART #	SIZE	LENGTH	
E6351	2.0x150mm	240.0mm	12
E6352	2.5x150mm	240.0mm	12
E6354	3.0x200mm	290.0mm	12
E6356	4.0x250mm	340.0mm	12
E6357	4.0x300mm	390.0mm	12
E6359	4.0x300mm	340.0mm	12
E6360	5.0x300mm	390.0mm	12
E6362	6.0x250mm	365.0mm	12
E6363	6.0x300mm	415.0mm	12
E6364	6.0x350mm	465.0mm	12
E6365	6.0x400mm	515.0mm	12

SCREWDRIVER SLOTTED



- TPR+PP two tone handle, ergonomic design, very comfortable
- Oil-proof design to protect handle
- Blade made of S2, heat treated, good torque and hardness
- Blade head black finished, magnetized

PART #	SIZE	LENGTH	
E6251	3x75mm	84.0mm	12
E6252	3x100mm	109.0mm	12
E6253	3x150mm	159.0mm	12
E6256	5x75mm	85.5mm	12
E6257	5x100mm	110.5mm	12
E6258	5x150mm	160.5mm	12
E6262	6x100mm	111.5mm	12
E6263	6x150mm	161.5mm	12
E6264	6x200mm	211.5mm	12
E6265	6x250mm	261.5mm	12
E6267	8x150mm	162.3mm	12
E6268	8x200mm	212.3mm	12

SCREWDRIVER PHILLIPS



- TPR+PP two tone handle, ergonomic design, very comfortable
- Oil-proof design to protect handle
- Blade made of S2, heat treated, good torque and hardness
- Blade head black finished, magnetized

PART #	SIZE	LENGTH	
E6271	PH0x75mm	84.0mm	12
E6272	PH0x100mm	109.0mm	12
E6273	PH0x150mm	159.0mm	12
E6276	PH1x75mm	85.5mm	12
E6277	PH1x100mm	110.5mm	12
E6278	PH1x150mm	160.5mm	12
E6282	PH2x100mm	111.5mm	12
E6283	PH2x150mm	161.5mm	12
E6284	PH2x200mm	211.5mm	12
E6285	PH2x250mm	261.5mm	12
E6287	PH3x150mm	162.3mm	12
E6288	PH3x200mm	212.3mm	12

NUT DRIVERS



- Two tone TPR rubber & plastic grip, comfortable to use.

PART #	SIZE	LENGTH	
E6431	3.2x125mm	225.0mm	12
E6432	4x125mm	225.0mm	12
E6433	5x125mm	225.0mm	12
E6434	5.5x125mm	225.0mm	12
E6435	6x125mm	235.0mm	12
E6436	7x125mm	235.0mm	12
E6437	8x125mm	235.0mm	12
E6438	9x125mm	235.0mm	12
E6439	10x125mm	245.0mm	12
E6440	11x125mm	245.0mm	12
E6441	12x125mm	245.0mm	12
E6442	13x125mm	245.0mm	12
E6443	14x125mm	245.0mm	12

SCREWDRIVER PH



- TPP+PP two tone handle, ergonomic design, very comfortable
- Oil-proof design to protect handle
- Blade made of S3, heat treated, good torque and hardness
- Blade head black finished, magnetized

PART #	SIZE	LENGTH	
E6281	PH2x25mm	82.0mm	12

SCREWDRIVER SLOTTED



- TPP+PP two tone handle, ergonomic design, very comfortable
- Oil-proof design to protect handle
- Blade made of S2, heat treated, good torque and hardness
- Blade head black finished, magnetized

PART #	SIZE	LENGTH	
E6261	6x25mm	82.0mm	12

T-HANDLE SOCKET ADAPTER



PART #	SIZE	LENGTH	
E6716	1/4"	103.0mm	12

T-HANDLE BIT ADAPTER



- Magnetized, comfortable to insert bit.

PART #	SIZE	LENGTH	📦
E6715	1/4"	200.0mm	12

NUT DRIVERS



PART #	SIZE	LENGTH	📦
E6461	5x125mm	168.0mm	12
E6462	5.5x125mm	168.0mm	12
E6463	6x125mm	168.0mm	12
E6464	7x125mm	168.0mm	12
E6465	8x125mm	168.0mm	12
E6466	9x125mm	168.0mm	12
E6467	10x125mm	175.0mm	12
E6468	11x125mm	175.0mm	12
E6469	12x125mm	175.0mm	12
E6470	13x125mm	175.0mm	12

BITS HANDLE



- Blade made of CR-V with ball inside

PART #	SIZE	LENGTH	📦
E6713	7X95mm	235.0mm	12

T-HANDLE SCREWDRIVER PHILLIPS



- Blade made of Cr - V.

PART #	SIZE	LENGTH	📦
E6721	#1	43.0mm	12
E6722	#2	93.0mm	12
E6723	#3	50.0mm	12

TORX SCREWDRIVER



- Two tone TPR rubber & plastic grip, comfortable to use.

PART #	SIZE	LENGTH	📦
E6451	T8X100mm	178.5mm	12
E6452	T10X100mm	178.5mm	12
E6453	T15X100mm	178.5mm	12
E6454	T20X100mm	178.5mm	12
E6455	T25X100mm	199.5mm	12
E6456	T27X100mm	199.5mm	12
E6457	T30X100mm	209.0mm	12
E6458	T40X100mm	209.0mm	12

SPINNER HANDLE



- Blade made of Cr-V, with ball.

PART #	SIZE	LENGTH	📦
E6703	8X75mm	210.0mm	12

BITS HANDLE



- Blade made of Cr - V, with ball.

PART #	SIZE	LENGTH	📦
E6711	7X95mm	220.0mm	12

19PC.IMPACT SCREWDRIVER SET



5-5/16"Dr. 30L bits slotted 5.5,6.5,8,10,12mm
 4-5/16"Dr. 30L bits phillips #1,#2,#3,#4
 4-5/16"Dr. 30L bits hex 5,6,8,10mm
 4-5/16"Dr. 70L bits slotted 8,10mm, Phillips #2,#3
 1-Impact handle
 1-5/16"Dr. impact bit adapter

- Handle made of premium grade steel, heat treated, durable.
- Bits made of S2, rust-off.

PART #	CONTENTS	△△	📦
E1139	19PCS	1.17kg	18

1/4" DR. 25L PHILLIPS BITS



- Made of S2 alloy steel, high hardness and torque.

PART #	SIZE	LENGTH	📦
E6821	#0	25.0mm	60
E6822	#1	25.0mm	60
E6823	#2	25.0mm	60
E6824	#3	25.0mm	60

1/4" DR. 25L SLOTTED BITS



- Made of S2 alloy steel, high hardness and torque.

PART #	SIZE	LENGTH	📦
E6811	3mm	25.0mm	60
E6812	4mm	25.0mm	60
E6813	5mm	25.0mm	60
E6814	5.5mm	25.0mm	60
E6815	6mm	25.0mm	60
E6816	6.5mm	25.0mm	60

1/4" DR. 25L HEX BITS



- Made of S2 alloy steel, high hardness and torque.

PART #	SIZE	LENGTH	📦
E6831	2mm	25.0mm	60
E6832	2.5mm	25.0mm	60
E6833	3mm	25.0mm	60
E6834	4mm	25.0mm	60
E6835	5mm	25.0mm	60
E6836	6mm	25.0mm	60

SCREWDRIVER BLADE



- Cr-Mo-V,S2 steel blades.
- Cr-Mo-V steel blades adopting advanced processing technology have more than twice longer life than those made of traditional Cr-V and can furthest enhance blades' hardness and torque with HRC58.

1/4" DR. 25L TORX BITS



• Made of S2 alloy steel, high hardness and torque.

PART #	SIZE	LENGTH	⚙️
E6841	T8	25.0mm	60
E6842	T10	25.0mm	60
E6843	T15	25.0mm	60
E6844	T20	25.0mm	60
E6845	T25	25.0mm	60
E6846	T27	25.0mm	60
E6847	T30	25.0mm	60
E6848	T40	25.0mm	60

1/4"DR.50L HEX BITS(METRIC)



• Made of S2 alloy steel, high hardness and torque.

PART #	SIZE	LENGTH	⚙️
E6873	3mm	50.0mm	60
E6874	4mm	50.0mm	60
E6875	5mm	50.0mm	60
E6876	6mm	50.0mm	60

5/16"Dr. 30L PHILLIPS BITS



• Made of S2 alloy steel, high hardness and torque.

PART #	SIZE	LENGTH	⚙️
E6911	1#	30.0mm	60
E6912	2#	30.0mm	60
E6913	3#	30.0mm	60
E6914	4#	30.0mm	60

1/4"DR. 50L SLOTTED BITS



• Made of S2 alloy steel, high hardness and torque.

PART #	SIZE	LENGTH	⚙️
E6851	3mm	50.0mm	60
E6852	4mm	50.0mm	60
E6853	5mm	50.0mm	60
E6854	5.5mm	50.0mm	60
E6855	6mm	50.0mm	60
E6856	6.5mm	50.0mm	60

1/4"DR.50L TORX BITS



• Made of S2 alloy steel, high hardness and torque.

PART #	SIZE	LENGTH	⚙️
E6882	T10	50.0mm	60
E6883	T15	50.0mm	60
E6884	T20	50.0mm	60

5/16"Dr. 30L HEX BITS



• Made of S2 alloy steel, high hardness and torque.

PART #	SIZE	LENGTH	⚙️
E6921	5mm	30.0mm	60
E6922	6mm	30.0mm	60
E6923	8mm	30.0mm	60
E6924	10mm	30.0mm	60
E6925	12mm	30.0mm	60
E6926	14mm	30.0mm	60

1/4"DR.50L PHILLIPS BITS



• Made of S2 alloy steel, high hardness and torque.

PART #	SIZE	LENGTH	⚙️
E6861	#0	50.0mm	60
E6862	#1	50.0mm	60
E6863	#2	50.0mm	60

5/16"Dr. 30L SLOTTED BITS



• Made of S2 alloy steel, high hardness and torque.

PART #	SIZE	LENGTH	⚙️
E6901	5.5mm	30.0mm	60
E6902	6.5mm	30.0mm	60
E6903	8mm	30.0mm	60
E6904	10mm	30.0mm	60
E6905	12mm	30.0mm	60

5/16"Dr. 30L SPLINE BITS



• Made of S2 alloy steel, high hardness and torque.

PART #	SIZE	LENGTH	⚙️
E6945	M5	30mm	60
E6946	M6	30mm	60
E6947	M8	30mm	60
E6948	M10	30mm	60
E6949	M12	30mm	60

5/16"Dr. 70L SPLINE BITS



PART #	SIZE	LENGTH	⚙️
E6965	M5	70.0mm	60
E6966	M6	70.0mm	60
E6967	M8	70.0mm	60
E6968	M10	70.0mm	60
E6969	M12	70.0mm	60

5/16"Dr. 70L TORX BITS



• Made of S2 alloy steel, high hardness and torque.

PART #	SIZE	LENGTH	⚙️
E6973	T20	70.0mm	60
E6975	T30	70.0mm	60
E6976	T40	70.0mm	60
E6977	T45	70.0mm	60
E6978	T50	70.0mm	60
E6979	T55	70.0mm	60

5/16"Dr. 30L TORX BITS



• Made of S2 alloy steel, high hardness and torque.

PART #	SIZE	LENGTH	⚙️
E6933	T20	30.0mm	60
E6934	T25	30.0mm	60
E6935	T27	30.0mm	60
E6936	T30	30.0mm	60
E6937	T40	30.0mm	60
E6938	T45	30.0mm	60
E6939	T50	30.0mm	60
E6940	T55	30.0mm	60

1/4"DR. DOUBLE END BITS



• Made of S2 alloy steel, high hardness and torque.

PART #	SIZE	LENGTH	⚙️
E6999	PH2-PH2	110.0mm	60

5/16"Dr. 70L HEX BITS



• Made of S2 alloy steel, high hardness and torque.

PART #	SIZE	LENGTH	⚙️
E6982	4mm	70.0mm	60
E6984	6mm	70.0mm	60
E6985	7mm	70.0mm	60
E6986	8mm	70.0mm	60
E6987	10mm	70.0mm	60
E6989	12mm	70.0mm	60

BITS HOLDER



• Blade made of Cr - V, with ball.
• Made of S2 alloy steel, high hardness and torque.

PART #	SIZE	LENGTH	⚙️
E6890	60mm (Magnetized)	60.0mm	60
E6892	25mm (Magnetized)	25.0mm	60
E6893	50mm (Magnetized)	50.0mm	60

5/16"Dr. 70L SLOTTED BITS



• Made of S2 alloy steel, high hardness and torque.

PART #	SIZE	LENGTH	⚙️
E6953	5.5mm	70.0mm	60
E6954	6.5mm	70.0mm	60
E6951	8mm	70.0mm	60
E6952	10mm	70.0mm	60

5/16"Dr. 70L PHILLIPS BITS



• Made of S2 alloy steel, high hardness and torque.

PART #	SIZE	LENGTH	⚙️
E6960	#1	70.0mm	60
E6961	#2	70.0mm	60
E6962	#3	70.0mm	60

1/4"DR.DOUBLE END BITS



• Made of S2 alloy steel, high hardness and torque.

PART #	SIZE	LENGTH	⚙️
E6994	PH1-PH1	65.0mm	60
E6995	PH2-PH2	65.0mm	60
E6996	PH3-PH3	65.0mm	60
E6997	5.5mm-PH2	65.0mm	60
E6998	PH1-PH2	65.0mm	60

1/4" DR. 6SL. MAGNETIC HEX NUT SETTER



- Made of high grade steel, heat treated, with internal magnetized equipment.

PART #	SIZE	LENGTH	📦
E4170	5mm	65.0mm	12
E4171	5.5mm	65.0mm	12
E4172	6mm	65.0mm	12
E4173	7mm	65.0mm	12
E4174	8mm	65.0mm	12
E4175	9mm	65.0mm	12
E4176	10mm	65.0mm	12
E4177	11mm	65.0mm	12
E4178	12mm	65.0mm	12
E4179	13mm	65.0mm	12
E4180	14mm	65.0mm	12

T52 BIT SOCKETS



- Blade made of S2, good torque and hardness
- Suitable for bolt removal of VW, AUDI, SEAT, SKODA

PART #	SIZE	LENGTH	📦
E4575	T52	125mm	12

M6 GEAR BOX SOCKET



- One cold forging, high torque and hardness

PART #	SIZE	LENGTH	📦
E4574	T16	60mm	12

41PC. 5/16" Dr. BITS SET



- 6-5/16" Dr. 30mm Hex Bits 5,6,8,10,12,14mm
- 8-5/16" Dr. 30mm Torx Bits T20,T25,T27,T30,T40,T45,T50,T55
- 4-5/16" Dr. 30mm Spline Bits M6,M8, M10,M12
- 2-5/16" Dr. 70mm Slotted Bits 5.5,6,5mm
- 3-5/16" Dr. 70mm Phillips Bits PH1,PH2,PH3
- 6-5/16" Dr. 70mm Torx Bits T20,T30,T40,T50,T55
- 5-5/16" Dr. 70mm Spline Bits M5,M6,M8,M10,M12
- 6-5/16" Dr.70mm Hex Bits 4,6,7,8,10,12mm
- 1-1/2" Dr. Adaptor

- Size: 380x140x52mm
- Bits made of S2, good torque and hardness

PART #	CONTENTS	ΔTΔ	📦
E1138	41PCS	2.0kg	1

ENDURA®
A Textron Company



7

PLIERS

LONG NOSE PLIERS



- Japanese type. Drop forged Cr - V.

PART #	SIZE	LENGTH	
E5141	6"	150.0mm	6
E5143	8"	200.0mm	6

LABORSAVING DIAGONAL PLIERS



- Pliers made of Cr-V
- Cutting thickness between 1.6mm-2.3mm for Medium hardness steel wire
- Center of rivet transferred to shearpoin,t.labor-saving at least 30% to 41%
- Use TPR Handle

PART #	SIZE	LENGTH	
E5202	6"	150.0mm	6
E5203	7"	175.0mm	6

SNAP RING PLIER SET



- 1-Body
- 2-Straight jaw (1.5;1.5)
- 2-Jaw (40o;90o)

PART #	CONTENTS	
E5530	5PCS	12

DIAGONAL PLIERS



- Drop-forged carbon steel.

PART #	SIZE	LENGTH	
E5221A	5"	125.0mm	6
E5222A	6"	150.0mm	6
E5223A	7"	175.0mm	6

LABORSAVING LINEMAN' S PLIERS



- Pliers made of Cr-V
- Cutting thickness between 1.6mm-2.3mm for Medium hardness steel wire
- Center of rivet transferred to shearpoin,t.labor-saving at least 30% to 41%
- Use TPR Handle

PART #	SIZE	LENGTH	
E5301	6"	152.0mm	6
E5302	7"	176.0mm	6
E5303	8"	203.0mm	6

LONG NOSE PLIERS



- Drop-forged carbon steel.

PART #	SIZE	LENGTH	
E5121A	6"	150.0mm	6
E5123A	8"	200.0mm	6

DIAGONAL PLIERS



- Drop forged Cr - V.
- Nickel iron steel plated, rust-proof.

PART #	SIZE	LENGTH	
E5232	6"	150.0mm	6
E5233	7"	175.0mm	6

HEAVY DUTY SNAP RING PLIERS SET



- Design refers to ratchet,easy to locate
- 3 design project:180 degree,90 degree,45 degree
- 4 plier head suit for different ring diameter:1.4mm 2.0mm 2.5mm 3.0mm

PART #	SIZE	LENGTH	
E5539	2	190mm	6

LONG NOSE PLIERS



- Drop forged Cr - V.
- Nickel iron steel plated, rust-proof.

PART #	SIZE	LENGTH	
E5131	6"	150.0mm	6
E5133	8"	200.0mm	6

LABORSAVING DIAGONAL PLIERS



- Pliers made of Cr-V
- Cutting thickness between 1.6mm-2.3mm for Medium hardness steel wire
- Center of rivet transferred to shearpoin,t.labor-saving at least 30% to 40%
- Use TPR Handle

PART #	SIZE	LENGTH	
E5101	6"	150.0mm	6
E5103	8"	200.0mm	6

DIAGONAL PLIERS



- Japanese type. Drop-forged Cr-V.

PART #	SIZE	LENGTH	
E5242	6"	150.0mm	6
E5243	7"	175.0mm	6

LINEMAN'S PLIERS



- German-type. Drop-forged Cr-V.

PART #	SIZE	LENGTH	
E5351	6"	152.0mm	6
E5352	7"	176.0mm	6
E5353	8"	203.0mm	6

CURVED JAWLOCKING PLIERS



- With micro-screw adjustment.
- Heat treated jaw. High tenacity and torque.

PART #	SIZE	LENGTH	
E5619	5"	144.0mm	6
E5620	7"	186.0mm	6
E5621	10"	222.0mm	6

PLASTIC CUTTING PLIERS



- Cr-V.
- Only suitable for plastic or soft cable.
- Not suitable for cutting hard steel material.
- Meet and exceed ANSI B107.11M

PART #	SIZE	LENGTH	
E5256	5"	125.0mm	6
E5257	6"	150.0mm	6
E5258	7"	175.0mm	6

LINEMAN' S PLIERS



- American type. Drop-forged premium grade carbon steel.

PART #	SIZE	LENGTH	
E5321A	6"	152.0mm	6
E5322A	7"	176.0mm	6
E5323A	8"	203.0mm	6

LONG NOSE LOCKING PLIERS W/CUTTING EDGE



- With micro-screw adjustment.
- Heat treated jaw. High tenacity and torque.

PART #	SIZE	LENGTH	
E5623	6.5"	165.1mm	6

STRAIGHT CUTTING SNIPS



- Made of Cr-V, with spring, convenient to use.
- Cutting thickness us to 1.25mm for cold-rolled iron sheet and 0.7mm for stainless steel plate.

PART #	SIZE	
E5525	8"	6
E5526	10"	6
E5527	12"	6
E5528	14"	6

LINEMAN' S PLIERS



- German-type. Drop-forged Cr-V.
- Nickel iron plated. Rust-proof.

PART #	SIZE	LENGTH	
E5331	6"	152.0mm	6
E5332	7"	176.0mm	6
E5333	8"	203.0mm	6

WELDING CLAMP LOCKING PLIERS



- With micro-screw adjustment.
- Heat treated jaw. High tenacity and torque.

PART #	SIZE	LENGTH	
E5625	10"	254.0mm	6

STRAIGHT JAWLOCKING PLIERS



- With micro-screw adjustment.
- Heat treated jaw. High tenacity and torque.

PART #	SIZE	LENGTH	
E5609	5"	144.0mm	6
E5610	7"	186.0mm	6
E5611	10"	222.0mm	6

LOCKING PLIERS



- With micro-screw adjustment.
- Heat treated jaw. High tenacity and torque.

PART #	SIZE	
E5626	8"	6

SNAP RING PLIERS EXTERNAL

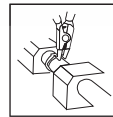

- Japanese-type. Made of Cr-V.
- Full polished body. Rust-proof and black finished treated.

PART #	SIZE	LENGTH	
E5532	7"	175.0mm	6
E5553	9"	225.0mm	6
E5554	13"	325.0mm	6

C - JAWLOCKING PLIERS



- With micro-screw adjustment.
- Heat treated jaw. High tenacity and torque.

PART #	SIZE	LENGTH	
E5627	11"	279.4mm	6

STRAIGHT CUTTING SNIPS



- Full polished.
- Cutting thickness up to 1.25 for cold-rolled iron sheet and 0.7mm for stainless plate.

PART #	SIZE	LENGTH	
E5521	8"	205.0mm	6
E5522	10"	255.0mm	6
E5523	12"	300.0mm	4

SNAP RING PLIERS INTERNAL

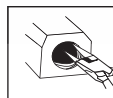

- Japanese-type. Made of Cr-V.
- Full polished body. Rust-proof and black finished treated.

PART #	SIZE	LENGTH	
E5533	7"	175.0mm	6
E5563	9"	255.0mm	6
E5564	13"	325.0mm	6

C-JAWLOCKING PLIERS



- With micro-screw adjustment.
- Heat treated jaw. High tenacity and torque.

PART #	SIZE	LENGTH	
E5628	18"	450	6

SNAP RING PLIERS EXTERNAL

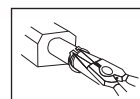

- Japanese-type. Made of Cr-V.
- Full polished body. Rust-proof and black finished treated.

PART #	SIZE	LENGTH	
E5531	7"	175.0mm	6
E5543	9"	225.0mm	6
E5544	13"	325.0mm	6

SNAP RING PLIERS INTERNAL

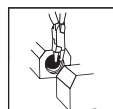

- Japanese-type. Made of Cr-V.
- Full polished body. Rust-proof and black finished treated.

PART #	SIZE	LENGTH	
E5534	7"	175.0mm	6
E5573	9"	225.0mm	6
E5574	13"	325.0mm	6

CRV MINI LONG NOSE PLIERS



- Made of Cr-V, with two spring.

PART #	SIZE	LENGTH	
E5731	4.5"	125.0mm	6

CRV MINIATURE FLAT BOSE PLIER



- Made of Cr-V, with two spring.

PART #	SIZE	LENGTH	
E5734	4.5"	125.0mm	6

CRV MINI FLAT FLIERS



- Made of Cr-V, with two spring.
- Jaw without teeth.

PART #	SIZE	LENGTH	
E5737	4.5"	110.0mm	6

CRV MINIATURE DIAGONAL PLIER



- Made of Cr-V, with two spring.

PART #	SIZE	LENGTH	
E5732	4.5"	110.0mm	6

CRV MINI BENT NOSE PLIERS



- Made of Cr-V, with two spring.

PART #	SIZE	LENGTH	
E5735	4.5"	125.0mm	6

GROOVE JOINT PLIERS



- Made of Cr-V
- Design for D4

PART #	SIZE	LENGTH	
E5511	8"	200.0mm	6
E5512	10"	250.0mm	6
E5513	12"	300.0mm	6

CRV MINIATURE LINEMAN'S PLIER



- Made of Cr-V, with two spring.

PART #	SIZE	LENGTH	
E5733	4.5"	120.0mm	6

CRV MINI END NIPPER



- Made of Cr-V, with two spring.

PART #	SIZE	LENGTH	
E5736	4.5"	110.0mm	6

GROOVE JOINT PLIERS



- Made of Cr-V. Design for D4.
- Jaw without teeth

PART #	SIZE	LENGTH	
E5496	10"	250.0mm	6

SLIP JOINT PLIERS



- Made of Cr-V

PART #	SIZE	LENGTH	
E5421	6"	150.0mm	6
E5422	8"	200.0mm	6
E5423	10"	250.0mm	6

CABLE CUTTER



- Drop-forged Cr-V .

PART #	SIZE	LENGTH	CUTTING RANGE	
E5281	6"	150mm	1.0-10.0mm	6
E5282	8"	200mm	1.0-11.0mm	6
E5283	10"	250mm	1.0-13.0mm	6

AVIATION SNIPS-STRAIGHT CUT



- Full polished.
- Cutting thickness up to 1.25mm for cold-rolled iron sheet and 0.7mm for stainless steel plate.

PART #	SIZE	LENGTH	
E5515	10"	250.0mm	6

SLIP JOINT PLIERS



- Made of Cr-V.

PART #	SIZE	LENGTH	
E5425	6"	150.0mm	6
E5426	8"	200.0mm	6

CUTTER



- Drop-forged Cr-V steel.
- Suitable for cutting 1.0-4.5mm wire.

PART #	SIZE	LENGTH	CUTTING RANGE	
E5273	8"	200mm	1.0-4.5mm	6

AVIATION SNIPS-LEFT CUT



- Full polished.
- Cutting thickness up to 1.25mm for cold-rolled iron sheet and 0.7mm for stainless steel plate.

PART #	SIZE	LENGTH	
E5516	10"	250.0mm	6

SLIP JOINT PLIERS



- Made of Cr-V.
- Design of rapid bending handle.

PART #	SIZE	LENGTH	
E5428	8"	200.0mm	6

CABLE CUTTER



- Drop-forged Cr-V.

PART #	SIZE	LENGTH	CUTTING RANGE	
E5284	10"	250mm	1.0-13.0mm	6

AVIATION SNIPS-RIGHT CUT



- Full polished.
- Cutting thickness up to 1.25mm for cold-rolled iron sheet and 0.7mm for stainless steel plate.

PART #	SIZE	LENGTH	
E5517	10"	250.0mm	6



8

HEX KEYS

9PC.LONG HEX KEY SET



9-Metric hex key set 1.5,2,2.5,3,4,5,6,8,10mm
 • Made of Cr-V. Heat treated.
 Inserted in nut easily with chamfer design at the end.

PART #	CONTENTS	ΔΔ	Weight	Count
E1551	9PCS	0.37kg		6

9PC. LONG BALL POINT HEX KEY SET



9-Metric hex key set 1.5,2,2.5,3,4,5,6,8,10mm
 • Made of Cr-V. Heat treated.
 Inserted in nut easily with chamfer design at the end.

PART #	CONTENTS	ΔΔ	Weight	Count
E1595	9PCS	0.4kg		6

8PC.FOLDING HEX KEY SET



8-Metric hex key set 1.5,2,2.5,3,4,5,6,8mm
 • Made of Cr-V. Heat treated.
 Inserted in nut easily with chamfer design at the end.

PART #	CONTENTS	ΔΔ	Weight	Count
E1574	8PCS	0.28kg		6

9PC.HEX KEY SET



9-Metric hex key set 1.5,2,2.5,3,4,5,6,8,10mm
 • Made of Cr-V. Heat treated.
 Inserted in nut easily with chamfer design at the end.

PART #	CONTENTS	ΔΔ	Weight	Count
E1553	9PCS	0.28kg		6

9PC. EXTRA LONG HEX KEY SET



9-Metric hex key set 1.5,2,2.5,3,4,5,6,8,10mm
 • Made of Cr-V. Heat treated.
 Inserted in nut easily with chamfer design at the end.

PART #	CONTENTS	ΔΔ	Weight	Count
E1596	9PCS	0.5kg		6

9PC.FOLDING HEX KEY SET



9-Hex key set 1/4", 7/32", 3/16", 5/64", 3/32", 7/64", 1/8", 9/64", 5/32"
 • Made of Cr-V; heat treated.
 Inserted in nut easily with chamfer design at the end.

PART #	CONTENTS	ΔΔ	Weight	Count
E1575	9PCS	0.28kg		6

9PC.LONG HEX KEY SET



9-Metric hex key set 1.5,2,2.5,3,4,5,6,8,10mm
 • Made of Cr-V. Heat treated.
 Inserted in nut easily with chamfer design at the end.

PART #	CONTENTS	ΔΔ	Weight	Count
E1554	9PCS	0.38kg		6

9PC. EXTRA LONG BALL POINT HEX KEY SET



9-Metric hex key set 1.5,2,2.5,3,4,5,6,8,10mm
 • Made of Cr-V. Heat treated.
 Inserted in nut easily with chamfer design at the end.

PART #	CONTENTS	ΔΔ	Weight	Count
E1597	9PCS	0.5kg		6

8PC.FOLDING TORX HEX KEY SET



8-Metric hex key set T9,T10,T15,T20,T25,T27,T30,T40
 • Made of Cr-V; heat treated.
 Inserted in nut easily with chamfer design at the end.

PART #	CONTENTS	ΔΔ	Weight	Count
E1576	8PCS	0.28kg		6

9PC. LONG HEX KEY SET



9-Metric hex key set 1.5,2,2.5,3,4,5,6,8,10mm
 • Made of Cr-V. Heat treated.
 Inserted in nut easily with chamfer design at the end.

PART #	CONTENTS	ΔΔ	Weight	Count
E1594	9PCS	0.5kg		6

9PC.LONG BALL POINT HEX KEY SET



9-Metric hex key set 1.5,2,2.5,3,4,5,6,8,10mm
 • Made of Cr-V; heat treated.
 • Inserted in nut easily with chamfer design at the end.
 Ball point, applied to narrow space.

PART #	CONTENTS	ΔΔ	Weight	Count
E1555	9PCS	0.38kg		6

9PC.EXTRA LONG HEX KEY SET



9-Metric hex key set 1.5,2,2.5,3,4,5,6,8,10mm
 • Made of S2; heat treated.
 Inserted in nut easily with chamfer design at the end.

PART #	CONTENTS	ΔΔ	Weight	Count
E1556	9PCS	0.49kg		6

8PC.TORX HEX KEY SET



8-Metric hex key set T6,T7,T8,T9,T10,T15,T20,T25
 • Made of Cr-V.

PART #	CONTENTS	ΔΔ	Weight	Count
E1560	8PCS	0.15kg		12

9PC.EXTRA LONG BALL POINT HEX KEY SET



9-Metric hex key set 1.5,2,2.5,3,4,5,6,8,10mm
 • Made of S2; heat treated.
 • Inserted in nut easily with chamfer design at the end.
 Ball point, applied to narrow space.

PART #	CONTENTS	ΔΔ	Weight	Count
E1557	9PCS	0.4kg		6

9PC. TORX HEX KEY SET



9-Metric hex key set T10,,T15,T20,T25,T27,T30,T40,T45,T50
 • Made of Cr-V.

PART #	CONTENTS	ΔΔ	Weight	Count
E1578	9PCS	0.35kg		12

9PC.EXTRA LONG (S.A.E) HEX KEY SET



9-Hex key set(S.A.E) 1/16",5/64",3/32",1/8",5/32",3/16",1/4",5/16",3/8"
 • Made of S2; heat treated.

PART #	CONTENTS	ΔΔ	Weight	Count
E1571	9PCS	0.47kg		6

8PC.HEX KEY SET



8-Metric hex key set 1.5,2,2.5,3,4,5,5.5,6mm
 • Made of Cr-V; heat treated.

PART #	CONTENTS	ΔΔ	Weight	Count
E1558	8PCS	0.08kg		12

9PC.EXTRA LONG (S.A.E) BALL POINT HEX KEY SET



9-Hex key set (S.A.E) 1/16",5/64",3/32",1/8",5/32",3/16",1/4",5/16",3/8"
 • Made of S2; heat treated.
 • Inserted in nut easily with chamfer design at the end.
 Ball point, applied to narrow space.

PART #	CONTENTS	ΔΔ	Weight	Count
E1572	9PCS	0.47kg		6

10PC.HEX KEY SET



10-Metric hex key set 1.5,2,2.5,3,4,5,5.5,6,8,10mm
 • Made of Cr-V; heat treated.

PART #	CONTENTS	ΔΔ	Weight	Count
E1559	10PCS	0.53kg		12

13PC.LONG HEX KEY SET



13-Metric hex key set 1.5,2,2.5,3,4,5,6,8,10,12,14,17,19mm

PART #	CONTENTS	ΔΔ	Weight	Count
E1586	13PCS	2.9kg		6

HEX KEY

Made of premium Cr-V. Heat treated.

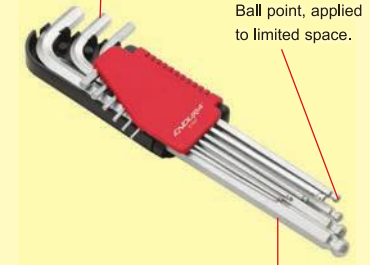

Ball point, applied to limited space.

Inserted in nut easily with chamfer design at the end.

• Meet and exceed ANSI&DIN.



12PC.LONG HEX KEY SET



12-Metric hex key set 1.5,2,2.5,3,4,5,6,7,8,10,12,14mm
 • Made of Cr-V; heat treated.
 Inserted in nut easily with chamfer design at the end.

PART #	CONTENTS	ΔTΔ	📦
E1573	12PCS	1.48kg	2

12PC. LONG BALL POINT HEX KEY SET



12-Metric hex key set 1.5,2,2.5,3,4,5,6,7,8,10,12,14mm
 • Made of Cr-V; heat treated.
 • Inserted in nut easily with chamfer design at the end.

PART #	CONTENTS	ΔTΔ	📦
E1581	12PCS	1.38kg	6

10PC. LONG HEX KEY SET



10-Metric hex key set 3,4,5,5.5,6,8,10,12,14,17mm
 • Made of Cr-V; heat treated.
 Inserted in nut easily with chamfer design at the end.

PART #	CONTENTS	ΔTΔ	📦
E1582	10PCS	2.065kg	4

10PC. LONG BALL POINT HEX KEY SET



10-Metric hex key set 3,4,5,5.5,6,8,10,12,14,17mm
 • Made of Cr-V; heat treated.
 • Inserted in nut easily with chamfer design at the end.

PART #	CONTENTS	ΔTΔ	📦
E1583	10PCS	2.06kg	4

HEX KEY



• Made of Cr-V; heat treated.
 Inserted in nut easily with chamfer design at the end.

PART #	SIZE	LENGTH	📦
E7511	1.5mm	45.0mm	72
E7512	2.0mm	50.0mm	72
E7513	2.5mm	56.0mm	72
E7514	3.0mm	63.0mm	72
E7515	4.0mm	70.0mm	72
E7516	5.0mm	80.0mm	72
E7517	6.0mm	90.0mm	72
E7518	7.0mm	95.0mm	72
E7519	8.0mm	100.0mm	36
E7520	10.0mm	112.0mm	24

LONG BALL POINT HEX KEY

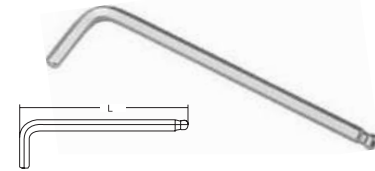

• Made of Cr-V; heat treated.
 • Inserted in nut easily with chamfer design at the end.

PART #	SIZE	LENGTH	📦
E7571	1.5mm	77.0mm	72
E7572	2.0mm	82.0mm	72
E7573	2.5mm	88.5mm	72
E7574	3.0mm	98.5mm	72
E7575	4.0mm	104.0mm	72
E7576	5.0mm	124.0mm	72
E7577	5.5mm	138.0mm	36
E7578	6.0mm	147.0mm	36
E7579	7.0mm	157.0mm	36
E7580	8.0mm	167.0mm	36
E7581	10.0mm	180.0mm	24
E7582	12.0mm	209.0mm	72
E7583	14.0mm	233.0mm	72
E7585	17.0mm	246.0mm	72
E7587	19.0mm	276.0mm	72

EXTRA LONG HEX KEY



• Made of S2; heat treated.
 Inserted in nut easily with chamfer design at the end.

PART #	SIZE	LENGTH	📦
E7591	1.5mm	90.0mm	72
E7592	2.0mm	100.0mm	72
E7593	2.5mm	112.0mm	72
E7594	3.0mm	126.0mm	72
E7595	4.0mm	140.0mm	72
E7596	5.0mm	160.0mm	72
E7597	6.0mm	180.0mm	36
E7598	7.0mm	190.0mm	36
E7599	8.0mm	200.0mm	36
E7600	10.0mm	224.0mm	24

EXTRA LONG BALL POINT HEX KEY



• Made of S2; heat treated.
 Inserted in nut easily with chamfer design at the end.

PART #	SIZE	LENGTH	📦
E7611	1.5mm	90.0mm	72
E7612	2.0mm	100.0mm	72
E7613	2.5mm	112.0mm	72
E7614	3.0mm	126.0mm	72
E7615	4.0mm	140.0mm	72
E7616	5.0mm	160.0mm	72
E7617	6.0mm	180.0mm	36
E7618	7.0mm	190.0mm	36
E7619	8.0mm	200.0mm	36
E7620	10.0mm	224.0mm	24

EXTRA LONG (S.A.E)HEX KEY



• Made of S2 steel. Full heated treated.

PART #	SIZE	LENGTH	📦
E7631	1/16"	90.0mm	72
E7632	5/64"	100.0mm	72
E7633	3/32"	112.0mm	72
E7634	1/8"	126.0mm	72
E7635	5/32"	140.0mm	72
E7636	3/16"	160.0mm	36
E7637	1/4"	180.0mm	36
E7638	5/16"	200.0mm	36
E7639	3/8"	224.0mm	36

LONG HEX KEY(METRIC)

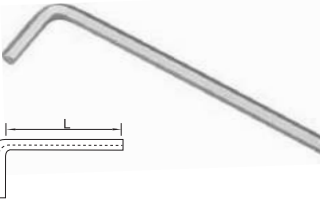

• Made of Cr-V;heat treated
 Inserted in nut easily with chamfer design at the end

PART #	SIZE	LENGTH	📦
E7551	1.5mm	77.0mm	72
E7552	2.0mm	82.0mm	72
E7553	2.5mm	88.5mm	72
E7554	3.0mm	98.5mm	72
E7555	4.0mm	104.0mm	72
E7556	5.0mm	124.0mm	72
E7550	5.5mm	138.0mm	72
E7557	6.0mm	138.0mm	36
E7558	7.0mm	147.0mm	36
E7559	8.0mm	157.0mm	36
E7560	10.0mm	167.0mm	24
E7561	12.0mm	209.0mm	24
E7562	14.0mm	233.0mm	24
E7563	16.0mm	240.0mm	24
E7564	17.0mm	246.0mm	24
E7565	18.0mm	261.0mm	24
E7566	19.0mm	276.0mm	24
E7567	22.0mm	330.0mm	16
E7568	24.0mm	370.0mm	16
E7569	27.0mm	410.0mm	12
E7588	30.0mm	430.0mm	4
E7589	32.0mm	450.0mm	4
E7590	36.0mm	470.0mm	4

T-HANDLE HEX KEY



• Made of Cr-Mo, high torque and tenacity.

PART #	SIZE	LENGTH	📦
E7832	2.5mm	133.0mm	12
E7833	3.0mm	133.0mm	12
E7834	4.0mm	173.0mm	12
E7835	5.0mm	183.0mm	12
E7836	6.0mm	228.0mm	12
E7838	8.0mm	240.0mm	12
E7839	10.0mm	240.0mm	12

T-HANDLE BALL POINT HEX KEY



• Inserted in nut easily with chamfer design at the end.

PART #	SIZE	LENGTH	📦
E7844	4.0mm	173.0mm	12
E7845	5.0mm	183.0mm	12
E7846	6.0mm	228.0mm	12
E7848	8.0mm	240.0mm	12
E7849	10.0mm	240.0mm	12

L-TYPE TORX WRENCH



• Made of Cr-V; heat treated.

PART #	SIZE	LENGTH	📦
E7161	T6	70.0mm	72
E7162	T7	74.0mm	72
E7163	T8	78.0mm	72
E7164	T9	82.0mm	72
E7165	T10	86.0mm	72
E7166	T15	90.0mm	72
E7167	T20	95.0mm	72
E7168	T25	100.0mm	72
E7169	T27	105.0mm	72
E7170	T30	114.0mm	36
E7171	T40	124.0mm	36
E7172	T45	133.0mm	36
E7173	T50	152.0mm	36

BALL POINT HEX KEY



• Two tone TPR handle.
 • Inserted in nut easily with chamfer design at the end.

PART #	SIZE	LENGTH	📦
E7872	2.0mm	165.0mm	12
E7873	2.5mm	165.0mm	12
E7874	3.0mm	190.0mm	12
E7875	4.0mm	190.0mm	12
E7876	5.0mm	190.0mm	12
E7877	6.0mm	240.0mm	12
E7879	8.0mm	265.0mm	12

T-HANDLE HEX KEY



• Made of Cr-Mo, high torque and tenacity.
 • Inserted in nut easily with chamfer design at the end.

PART #	SIZE	LENGTH	📦
E7804	4.0mm	243.0mm	12
E7805	5.0mm	243.0mm	12
E7806	6.0mm	243.0mm	12
E7808	8.0mm	250.0mm	12
E7809	10.0mm	250.0mm	12

T-HANDLE TORX WRENCH



PART #	SIZE	LENGTH	📦
E7383	T20	143.0mm	12
E7384	T25	143.0mm	12
E7385	T27	158.0mm	12
E7386	T30	158.0mm	12
E7387	T40	180.0mm	12
E7388	T45	200.0mm	12
E7389	T50	200.0mm	12

T-HANDLE TORX WRENCH



PART #	SIZE	LENGTH	📦
E7411	T6	133.0mm	12
E7412	T7	133.0mm	12
E7413	T8	133.0mm	12
E7414	T9	133.0mm	12
E7415	T10	133.0mm	12
E7416	T15	133.0mm	12
E7417	T20	173.0mm	12
E7418	T25	183.0mm	12
E7419	T27	183.0mm	12
E7420	T30	228.0mm	12
E7421	T40	240.0mm	12
E7422	T45	240.0mm	12
E7423	T50	240.0mm	12

EXTRA LONG BALL POINT(S.A.E) HEX KEY

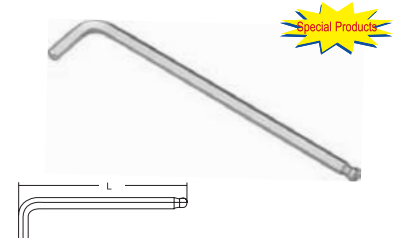

• Made of S2; heat treated.
 • Inserted in nut easily with chamfer design at the end.

PART #	SIZE	LENGTH	📦
E7641	1/16"	90.0mm	72
E7642	5/64"	100.0mm	72
E7643	3/32"	112.0mm	72
E7644	1/8"	126.0mm	72
E7645	5/32"	140.0mm	72
E7646	3/16"	160.0mm	36
E7647	1/4"	180.0mm	36
E7648	5/16"	200.0mm	36
E7649	3/8"	224.0mm	24



TORQUE WRENCH

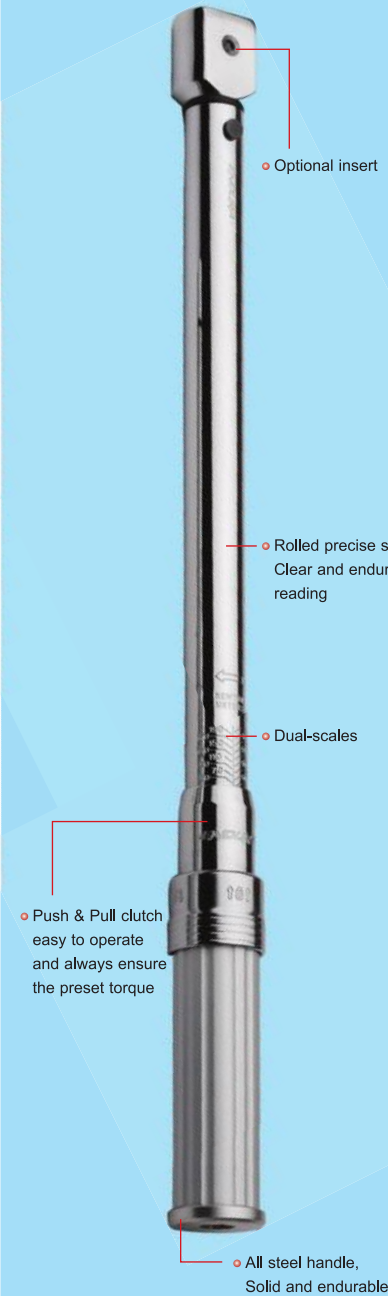

Push & Pull clutch easy to operate and always ensure the preset torque

Optional insert

Rolled precise scale, Clear and durable reading

Dual-scales

All steel handle, Solid and durable

- Steel alloy. Solid and durable.
- With comfortable and easy-to-use handle.
- Easy to adjust setting value.
- Used clockwise and counterclockwise.
- With readable and precise metric and imperial scale.
- Maximum erroneous precision: 3%.
- Meet and exceed ASME B107.14.

9

TORQUE TOOLS

TORQUE WRENCH

1/4"



- Made of steel alloy, 45 teeth, apply to narrow space.
- Humanization design metal handles
- Warning at the predetermined torque value.
- Maximum erroneous precision: 3%
- Meet and exceed ASME B107.14.

PART #	SIZE	DRIVER	LENGTH	QTY
E0971	2.5-12 N.m	1/4"	280.0mm	1
E0972	4.0-20 N.m	1/4"	280.0mm	1

TORQUE WRENCH

3/8"



- Made of steel alloy, 45 teeth, apply to narrow space.
- Humanization design metal handles
- Warning at the predetermined torque value.
- Maximum erroneous precision: 3%
- Meet and exceed ASME B107.14.

PART #	SIZE	DRIVER	LENGTH	QTY
E0973	4.5-30N.m	3/8"	315.0mm	1
E0974	10-60N.m	3/8"	365.0mm	1
E0975	25-125N.m	3/8"	425.0mm	1

TORQUE WRENCH

1/2"



- Made of steel alloy, 45 teeth, apply to narrow space.
- Humanization design metal handles
- Warning at the predetermined torque value.
- Maximum erroneous precision: 3%
- Meet and exceed ASME B107.14.

PART #	SIZE	DRIVER	LENGTH	QTY
E0924	10-60N.m	1/2"	365.0mm	1
E0925	25-125N.m	1/2"	425.0mm	1
E0976	40-200N.m	1/2"	465.0mm	1
E0977	65-335N.m	1/2"	525.0mm	1

TORQUE WRENCH

3/4"



- Made of steel alloy, 45 teeth, apply to narrow space.
- Humanization design metal handles
- Warning at the predetermined torque value.
- Maximum erroneous precision: 3%
- Meet and exceed ASME B107.14.

PART #	SIZE	DRIVER	LENGTH	QTY
E0934	100-500N.m	3/4"	855.0mm	1
E0935	160-800N.m	3/4"	1055.0mm	1
E0936	200-1000N.m	3/4"	1055.0mm	1

TORQUE WRENCH

1"



- Made of steel alloy, 45 teeth, apply to narrow space.
- Humanization design metal handles
- Warning at the predetermined torque value.
- Maximum erroneous precision: 3%
- Meet and exceed ASME B107.14.

PART #	SIZE	DRIVER	LENGTH	QTY
E0937	160-800N.m	1"	1260.0mm	1
E0938	200-1000N.m	1"	1260.0mm	1
E0939	300-1500N.m	1"	1260.0mm	1

9X12 MALE TORQUE WRENCH



- Can be matched with 9x12mm ratchet, openings, blossom plugin
- Torque could be Made-to-order.
- Humanization design metal handles
- Warning at the predetermined torque value.
- Maximum erroneous precision: 3%
Meet and exceed ASME B107.14.

PART #	SIZE	MALE	LENGTH	
E0981	2.5-12N.m	9x12mm	265.0mm	1
E0982	4.0-20N.m	9x12mm	265.0mm	1
E0983	4.5-30N.m	9x12mm	300.0mm	1
E0984	10-60N.m	9x12mm	350.0mm	1
E0985	25-125N.m	9x12mm	400.0mm	1

24X32 MALE TORQUE WRENCH



- Can be matched with 24X32mm ratchet, openings, blossom plugin
- Torque could be Made-to-order.
- Humanization design metal handles
- Warning at the predetermined torque value.
- Maximum erroneous precision: 3%
Meet and exceed ASME B107.14.

PART #	SIZE	MALE	LENGTH	
E0955	100-500N.m	24x32mm	855.0mm	1
E0956	160-800N.m	24x32mm	1055.0mm	1
E0957	200-1000N.m	24x32mm	1055.0mm	1

14X18 MALE TORQUE WRENCH



- Can be matched with 14X18mm ratchet, openings, blossom plugin
- Torque could be Made-to-order.
- Humanization design metal handles
- Warning at the predetermined torque value.
- Maximum erroneous precision: 3%
Meet and exceed ASME B107.14.

PART #	SIZE	MALE	LENGTH	
E0986	40-200N.m	14x18mm	460.0mm	1
E0987	65-335N.m	14x18mm	520.0mm	1

27X36 MALE TORQUE WRENCH



- Can be matched with 27X36mm ratchet, openings, blossom plugin
- Torque could be Made-to-order.
- Humanization design metal handles
- Warning at the predetermined torque value.
- Maximum erroneous precision: 3%
Meet and exceed ASME B107.14.

PART #	SIZE	MALE	LENGTH	
E0958	300-1500N.m	27x36mm	1260.0mm	1

TORQUE WRENCH



- Made of steel alloy, 45 teeth, apply to narrow space.
- Humanization design metal handles
- Warning at the predetermined torque value.
- Maximum erroneous precision: 3%
Meet and exceed ASME B107.14.

PART #	SIZE	DRIVER	LENGTH	
E0929	400-2000 N.m	1"	1600.0mm	1
E0930	600-3000 N.m	1"	1840.0mm	1

TORQUE WRENCH



- Can be matched with 27X36mm ratchet, openings, blossom plugin
- Torque could be Made-to-order.
- Humanization design metal handles
- Warning at the predetermined torque value.
- Maximum erroneous precision: 3%
Meet and exceed ASME B107.14.

PART #	SIZE	MALE	LENGTH	
E0959	400-2000 N.m	27x36mm	1600.0mm	1
E0960	600-3000 N.m	27x36mm	1840.0mm	1

EXTRA LONG TORQUE WRENCH

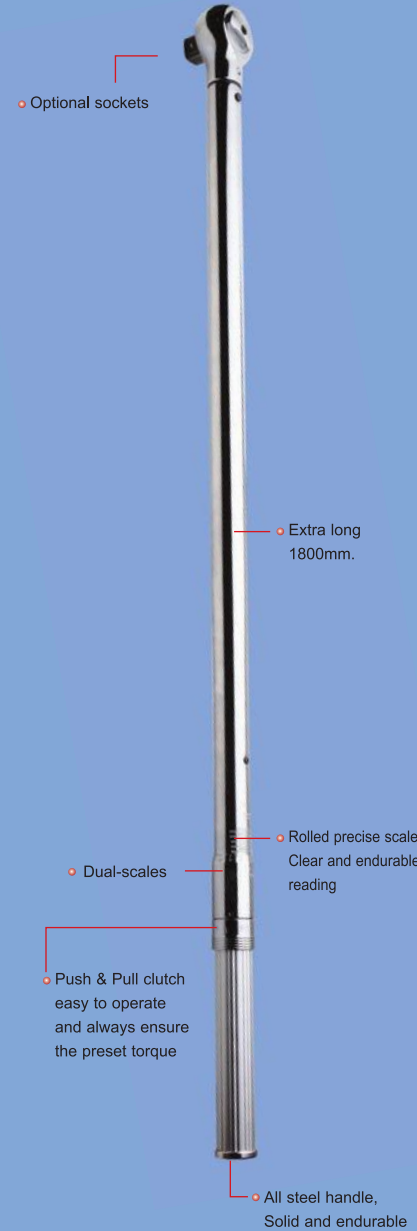

Optional sockets

Extra long 1800mm.

Rolled precise scale, Clear and durable reading

Dual-scales

Push & Pull clutch easy to operate and always ensure the preset torque

All steel handle, Solid and durable

- Steel alloy. Solid and durable.
- With comfortable and easy-to-use handle.
- Easy to adjust setting value.
- Used clockwise and counterclockwise.
- With readable and precise metric and imperial scale.
- Maximum erroneous precision: 3%.
Meet and exceed ASME B107.14.

TORQUE WRENCH



- Made of steel alloy, 45 teeth, apply to narrow space.
- Humanization design metal handles
- Warning at the predetermined torque value.
- Maximum erroneous precision: 3%
Meet and exceed ASME B107.14.

PART #	SIZE	DRIVER	LENGTH	
E0911	2.5-12N.m	1/4"	275.0mm	1
E0912	4.0-20N.m	1/4"	275.0mm	1
E0921	4.5-30N.m	3/8"	310.0mm	1
E0923	10-60N.m	3/8"	360.0mm	1
E0922	25-125N.m	3/8"	420.0mm	1
E0932	40-200N.m	1/2"	460.0mm	1
E0933	65-335N.m	1/2"	520.0mm	1
E0941	100-500N.m	3/4"	840.0mm	1
E0942	160-800N.m	3/4"	1040.0mm	1
E0943	200-1000N.m	3/4"	1040.0mm	1
E0946	300-1500N.m	1"	1250.0mm	1
E0947	400-2000N.m	1"	1250.0mm	1
E0948	600-3000N.m	1"	1250.0mm	1

TORQUE WRENCH

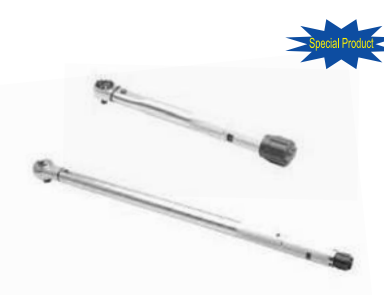

- Made of steel alloy, 45 teeth, apply to narrow space.
- Humanization design metal handles
- Warning at the predetermined torque value
- Maximum erroneous precision: 4%
Meet and exceed ASME B107.44

PART #	SIZE	DRIVER	LENGTH	
T0972	3-12N.m	1/4"	275.0mm	1
T0973	4-20N.m	1/4"	275.0mm	1
T0975	6-30N.m	3/8"	318.0mm	1
T0976	10-60N.m	3/8"	352.0mm	1
T0977	20-100N.m	3/8"	400.0mm	1
T0981	30-150N.m	1/2"	430.0mm	1
T0982	40-200N.m	1/2"	470.0mm	1
T0983	50-250N.m	1/2"	530.0mm	1
T0984	60-340N.m	1/2"	580.0mm	1
T0986	100-500N.m	3/4"	850.0mm	1
T0987	150-800N.m	3/4"	1050.0mm	1
T0988	200-1000N.m	3/4"	1050.0mm	1
T0991	300-1500N.m	1"	1260.0mm	1
T0992	400-2000N.m	1"	1260.0mm	1
T0993	500-2500N.m	1"	1260.0mm	1

TORQUE WRENCH



- MadCan be matched with 9X12mm ratchet, openings, blossom plugin
- Torque could be Made-to-order.
- Humanization design metal handles
- Warning at the predetermined torque value.
- Maximum erroneous precision: 3%
Meet and exceed ASME B107.14.

PART #	SIZE	MALE	LENGTH	
E0950	2.5-12N.m	9x12mm	275.0mm	1
E0951	4.0-20N.m	9x12mm	275.0mm	1
E0952	4.5-30N.m	9x12mm	310.0mm	1
E0953	10-60N.m	9x12mm	360.0mm	1
E0954	25-125N.m	9x12mm	420.0mm	1
E0961	40-200N.m	14x18mm	460.0mm	1
E0962	65-335N.m	14x18mm	520.0mm	1
E0964	100-500N.m	24x32mm	850.0mm	1
E0965	160-800N.m	24x32mm	1050.0mm	1
E0966	200-1000N.m	24x32mm	1050.0mm	1
E0967	300-1500N.m	27x36mm	1250.0mm	1
E0968	400-2000N.m	27x36mm	1250.0mm	1
E0969	600-3000N.m	27x36mm	1250.0mm	1

REVERSIBLE RATCHET HEAD



- Material: Cr-V
- Precision processing and durable
- Apply for narrow work place.
- Mark * is made-to-order.

PART #	DRIVER	MALE	LENGTH	
T0805*	3/4"	24x32mm	35.0mm	6
T0806*	1"	27x36mm	50.0mm	6

TORQUE MULTIPLIERS



- Made of Cr-V

PART #	DRIVE	MAXTORQUE	LENGTH	
E0991	1/2"-3/4"	1000N.m	1:3.3	1
E0993	1/2"-3/4"	1000N.m	1:5	1
E0994	1/2"-1"	1500N.m	1:5	1
E0992*	1/2"-1"	2500N.m	1:25	1
E0995*	1/2"- 1 1/2"	3500N.m	1:25	1
E0996*	1/2"- 1 1/2"	4000N.m	1:25	1
E0997*	1/2"- 1 1/2"	6000N.m	1:25	1
E0998*	1/2"- 1 1/2"	8000N.m	1:25	1

REVERSIBLE RATCHET HEAD



- Made of Cr-V, durable

PART #	DRIVER	MALE	LENGTH	
T0801	1/4"	9x12mm	17.5mm	6
T0802	3/8"	9x12mm	17.5mm	6
T0804	1/2"	9x12mm	17.5mm	6
T0803	1/2"	14x18mm	25.0mm	6

REVERSIBLE RATCHET HEAD



- Made of Cr-V, durable

PART #	DRIVER	MALE	LENGTH	
T0904	3/4"	14x18mm	90.0mm	6

ADJUSTABLE WRENCH HEAD



- Made of Cr-V, durable

PART #	SIZE	LENGTH	
T0697	8"	9x12mm	6
T0698	10"	9x12mm	6
T0699	10"	14x18mm	6
T0700	12"	14x18mm	6

TORQUE MULTIPLIERS

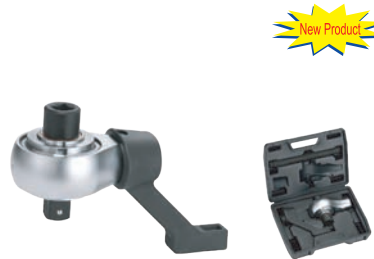

- Made of steel alloy, easy to maintain and have a long service life
- Special design with two reaction arm to different situation
- Maximum erroneous precision: 5%

PART#	DRIVER	MAX TORQUE	RATIO	
E0988	1/2"-3/4"	1500N.m	1:5	1
E0989	3/4"-1"	2700N.m	1:5	1
E0990	1/2"-1"	4500N.m	1:26	1

DIGIMATIC TORQUE WRENCH



- Using implantable induction chip, have higher precision than common electronic wrench. More durable and save electricity.
- Rapid fall off ratchet head, improve work efficiency.
- LCD display, digital display, avoid reading error.
- Alarm system, LED lights warning, and a buzz hints.
- Computer chips and software, self-developed patent chip and software, convenient operation and calibration.
- Maximum erroneous precision: 2%

PART #	SIZE	DRIVER	LENGTH	
E0902	10.0-135.0N.m	3/8"	400.0mm	1
E0904	20.0-200.0N.m	1/2"	570.0mm	1
E0906	34.0-340.0N.m	1/2"	770.0mm	1

TORQUE WRENCH



- Torque could be Made-to-order.
- Special torque wrench, which can effectively improve the use efficiency
- Maximum erroneous precision: 3%
- Meet and exceed ASME B107.14.

PART #	SIZE	DRIVER	LENGTH	
T0911	2.5-12N.m	1/4"	275.0mm	1
T0912	4.0-20N.m	1/4"	275.0mm	1
T0921	4.5-30N.m	3/8"	310.0mm	1
T0923	10-60N.m	3/8"	360.0mm	1
T0922	25-125N.m	3/8"	420.0mm	1
T0932	40-200N.m	1/2"	460.0mm	1
T0933	65-335N.m	1/2"	520.0mm	1
T0941	100-500N.m	3/4"	840.0mm	1
T0942	160-800N.m	3/4"	1040.0mm	1
T0943	200-1000N.m	3/4"	1040.0mm	1
T0946	300-1500N.m	1"	1250.0mm	1
T0947	400-2000N.m	1"	1250.0mm	1
T0948	600-3000N.m	1"	1250.0mm	1

TORQUE WRENCH



- Torque could be Made-to-order.
- Special torque wrench, which can effectively improve the use efficiency
- Maximum erroneous precision: 3%
- Meet and exceed ASME B107.14.

PART #	SIZE	MALE	LENGTH	
T0950	2.5-12N.m	9x12mm	275.0mm	1
T0951	4.0-20N.m	9x12mm	275.0mm	1
T0952	4.5-30N.m	9x12mm	310.0mm	1
T0953	10-60N.m	9x12mm	360.0mm	1
T0954	25-125N.m	9x12mm	420.0mm	1
T0961	40-200N.m	14x18mm	460.0mm	1
T0962	65-335N.m	14x18mm	520.0mm	1
T0964	100-500N.m	24x32mm	850.0mm	1
T0965	160-800N.m	24x32mm	1050.0mm	1
T0966	200-1000N.m	24x32mm	1050.0mm	1
T0967	300-1500N.m	27x36mm	1250.0mm	1
T0968	400-2000N.m	27x36mm	1250.0mm	1
T0969	600-3000N.m	27x36mm	1250.0mm	1

TORQUE CONTROL GUIDE

μ = 0.10

ISO 272	ISO mm	mm	Cs(N.m)	Fo(N)
1.6	0.35	3.2	0.128	555
2	0.4	4	0.27	921
2.5	0.45	5	0.556	1533
3	0.5	5.5	0.95	2298
4	0.7	7	2.2	3985
5	0.8	8	4.34	6514
6	1	10	7.5	9195
8	1.25	13	18.2	16863
10	1.5	16	36	26838
12	1.75	18	62	39119
14	2	21	99	53707
16	2	24	153	73808
18	2.5	27	220	92440
20	2.5	30	311	119003
22	2.5	34	424	148374
24	3	36	534	171437
27	3	41	784	225110
30	3.5	46	1067	274030
33	3.5	50	1442	341347
36	4	55	1855	400571
39	4	60	2399	481158
42	4.5	65	2965	550683
45	4.5	70	3698	644534
48	5	75	4470	724359
52	5	80	5737	869013
56	5.5	85	7161	1003549
60	5.5	90	8871	1172365
64	6	95	10683	1326146

μ = 0.15

ISO 272	ISO mm	mm	Cs(N.m)	Fo(N)
1.6	0.35	3.2	0.16	499
2	0.4	4	0.339	829
2.5	0.45	5	0.705	1382
3	0.5	5.5	1.21	2075
4	0.7	7	2.78	3594
5	0.8	8	5.5	5886
6	1	10	9.5	8302
8	1.25	13	23	15242
10	1.5	16	46	24275
12	1.75	18	79	35401
14	2	21	127	48618
16	2	24	198	66955
18	2.5	27	283	83746
20	2.5	30	402	107941
22	2.5	34	552	134806
24	3	36	691	155489
27	3	41	1022	204577
30	3.5	46	1387	248811
33	3.5	50	1884	310343
36	4	55	2418	363974
39	4	60	3139	437669
42	4.5	65	3872	500694
45	4.5	70	4847	586548
48	5	75	5849	658966
52	5	80	7335	791306
56	5.5	85	9394	913378
60	5.5	90	11673	1067916
64	6	95	14041	1207731

RECTANGULAR OPEN END FITTING



- Material: Cr-V
- Precision processing and durable
- Apply to narrow work place.
- Mark * is made-to-order.

PART #	SIZE (mm)	MALE (mm)	L (mm)	H (mm)	D (mm)	
T0741*	6	9x12	20.1	5.0	22.0	6
T0811	7	9x12	20.6	5.0	22.0	6
T0812	8	9x12	21.0	5.0	22.0	6
T0813	9	9x12	21.4	5.5	26.0	6
T0814	10	9x12	21.8	5.5	26.0	6
T0815	11	9x12	22.3	5.5	26.0	6
T0816	12	9x12	22.7	7.0	30.0	6
T0817	13	9x12	23.1	7.0	30.0	6
T0818	14	9x12	23.6	8.0	35.0	6
T0819	15	9x12	24.0	8.0	35.0	6
T0820	16	9x12	24.5	8.0	38.0	6
T0821	17	9x12	24.9	8.0	38.0	6
T0822	18	9x12	25.8	8.0	42.0	6
T0823	19	9x12	26.3	8.0	42.0	6
T0824	20	9x12	26.6	8.0	48.0	6
T0826	21	9x12	27.1	8.0	50.0	6
T0825	22	9x12	27.6	8.0	50.0	6
T0702	23	9x12	28.0	8.0	53.0	6
T0703	24	9x12	28.5	8.0	53.0	6
T0704	25	9x12	29.0	8.0	53.0	6
T0867*	26	9x12	29.0	8.0	53.0	6
T0705	27	9x12	29.5	8.0	64.0	6
T0706	28	9x12	30.0	8.0	68.0	6
T0809*	30	9x12	31.0	8.0	70.0	6
T0827	32	9x12	32.0	8.0	70.0	6
T0808*	34	9x12	33.0	8.0	80.0	6
T0999*	35	9x12	34.0	8.0	80.0	6
T0693*	36	9x12	35.0	8.0	80.0	6
T0810*	37	9x12	36.0	8.0	81.0	6
T0742*	38	9x12	37.0	8.0	82.0	6
T0901*	39	9x12	38.0	8.0	83.0	6
T0998*	41	9x12	39.0	8.0	85.0	6
T0743*	42	9x12	40.0	8.0	90.0	6
T0744*	45	9x12	41.0	8.0	100.0	6
T0745*	46	9x12	42.0	8.0	100.0	6
T0746*	49	9x12	43.0	8.0	106.0	6
T0747	50	9x12	44.0	8.0	106.0	6
T0748*	52	9x12	45.0	8.0	110.0	6
T0749*	55	9x12	46.0	8.0	116.0	6
T0750*	60	9x12	48.0	8.0	121.0	6
T0761*	65	9x12	50.0	8.0	126.0	6
T0762*	67	9x12	51.0	8.0	128.0	6
T0710*	8	14x18	28.2	7.0	32.0	6
T0763*	9	14x18	28.7	7.0	32.0	6
T0828*	10	14x18	29.2	7.0	32.0	6
T0990*	11	14x18	29.7	7.0	32.0	6
T0830*	12	14x18	30.2	7.0	32.0	6
T0831	13	14x18	30.7	7.0	32.0	6
T0832	14	14x18	31.1	8.0	35.0	6
T0833	15	14x18	31.5	8.0	35.0	6
T0834	16	14x18	31.9	9.0	38.0	6
T0835	17	14x18	32.4	9.0	38.0	6
T0836	18	14x18	32.8	10.0	42.0	6
T0837	19	14x18	33.3	10.0	42.0	6
T0893*	20	14x18	33.8	11.0	50.0	6
T0838	21	14x18	34.1	11.0	50.0	6
T0839	22	14x18	34.9	11.0	50.0	6
T0692*	23	14x18	35.0	13.0	53.0	6
T0840	24	14x18	35.4	13.0	53.0	6

RECTANGULAR RING END FITTING

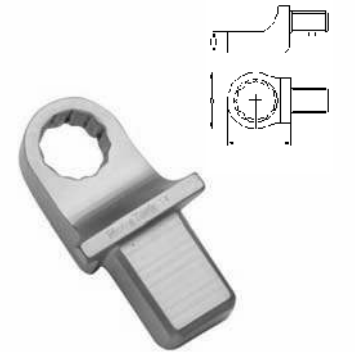

- Material: Cr-V
- Precision processing and durable
- Apply to narrow work place.
- Mark * is made-to-order.

PART #	SIZE (mm)	MALE (mm)	L (mm)	H (mm)	D (mm)	
T0667*	6	9x12	23.2	8.0	12.0	6
T0851	7	9x12	24.0	8.0	13.0	6
T0852	8	9x12	24.6	8.0	14.0	6
T0668*	9	9x12	25.5	9.0	16.0	6
T0853	10	9x12	26.1	9.0	17.0	6
T0854	11	9x12	26.8	9.0	18.5	6
T0855	12	9x12	27.5	12.0	20.0	6
T0856	13	9x12	28.5	12.0	22.0	6
T0857	14	9x12	29.0	12.0	23.0	6
T0858	15	9x12	29.5	12.0	24.0	6
T0859	16	9x12	30.4	13.0	26.0	6
T0860	17	9x12	31.1	13.0	27.0	6
T0861	18	9x12	31.8	13.0	28.5	6
T0862	19	9x12	32.6	13.0	30.0	6
T0865	20	9x12	33.6	13.0	33.0	6
T0863	21	9x12	34.0	13.0	33.0	6
T0864	22	9x12	34.8	13.0	34.5	6
T0669*	24	9x12	34.8	13.0	37.5	6
T0670*	25	9x12	35.0	13.0	40.0	6
T0671*	27	9x12	35.8	13.0	41.5	6
T0672*	30	9x12	3			

PART #	SIZE (mm)	MALE (mm)	L (mm)	H (mm)	D (mm)	
T0680*	65	14 x 18	94.9	16.0	90.0	6
T0681*	70	14 x 18	103.0	16.0	96.0	6
T0682*	75	14 x 18	110.0	16.0	100.0	6
T0751	24	24 x 32	67.5	25.0	65.0	6
T0752	27	24 x 32	69.0	25.0	68.0	6
T0753	30	24 x 32	71.1	25.0	72.0	6
T0754	32	24 x 32	72.0	25.0	74.0	6
T0755	34	24 x 32	73.0	25.0	76.0	6
T0756	36	24 x 32	79.7	25.0	80.0	6
T0683*	38	24 x 32	80.0	25.0	80.0	6
T0757	41	24 x 32	85.0	25.0	80.0	6
T0758	46	24 x 32	87.0	25.0	84.0	6
T0759	50	24 x 32	99.0	25.0	98.0	6
T0760	55	24 x 32	107.5	25.0	105.0	6
T0684*	60	24 x 32	115.0	25.0	110.0	6
T0685*	65	24 x 32	129.0	25.0	128.0	6
T0686*	70	24 x 32	129.0	25.0	128.0	6
T0687*	30	27 x 36	85.0	28.0	70.0	6
T0688*	32	27 x 36	85.0	28.0	70.0	6
T0771	34	27 x 36	87.5	28.0	75.0	6
T0772	36	27 x 36	87.5	28.0	75.0	6
T0689*	38	27 x 36	90.0	28.0	80.0	6
T0773	41	27 x 36	90.0	28.0	80.0	6
T0774	46	27 x 36	93.0	28.0	86.0	6
T0775	50	27 x 36	99.0	28.0	98.0	6
T0776	55	27 x 36	107.5	28.0	105.0	6
T0777	60	27 x 36	115.0	28.0	110.0	6
T0778	65	27 x 36	119.0	28.0	118.0	6
T0779	70	27 x 36	129.0	28.0	128.0	6
T0690*	75	27 x 36	144.0	28.0	138.0	6
T0691*	80	27 x 36	154.0	28.0	148.0	6

TORQUE WRENCH

1/4" 3/8"



- Easy to use
- 180 degree rotate to select metric or B.S.
- Maximum erroneous precision: 3%
- Meet ASME B107.14

PART #	SIZE	DRIVER	LENGTH	
T0913	0-2N.m	1/4"	310.0mm	1
T0914	0-3N.m	1/4"	310.0mm	1
T0915	0-6N.m	1/4"	310.0mm	1
T0916	0-8N.m	1/4"	310.0mm	1
T0920	0-12N.m	3/8"	310.0mm	1
T0924	0-17.5N.m	3/8"	310.0mm	1
T0925	0-20N.m	3/8"	310.0mm	1
T0926	0-25N.m	3/8"	310.0mm	1
T0927	0-30N.m	3/8"	310.0mm	1
T0928	0-35N.m	3/8"	400.0mm	1
T0929	0-40N.m	3/8"	400.0mm	1
T0930	0-50N.m	3/8"	400.0mm	1
T0931	0-60N.m	3/8"	400.0mm	1

TORQUE WRENCH

1/2" 3/4" 1"



- Easy to use
- 180 degree rotate to select metric or B.S.
- Maximum erroneous precision: 3%
- Meet ASME B107.14

PART #	SIZE	DRIVER	LENGTH	
T0934	0-100N.m	1/2"	480.0mm	1
T0935	0-120N.m	1/2"	480.0mm	1
T0936	0-140N.m	1/2"	480.0mm	1
T0937	0-200N.m	1/2"	550.0mm	1
T0938	0-250N.m	1/2"	550.0mm	1
T0939	0-275N.m	1/2"	550.0mm	1
T0940	0-350N.m	1/2"	550.0mm	1
T0980	0-400N.m	3/4"	818.0mm	1
T0985	0-500N.m	3/4"	818.0mm	1
T0994	0-800N.m	3/4"	1192.0mm	1
T0995	0-1000N.m	3/4"	1192.0mm	1
T0996	0-1400N.m	1"	1620.0mm	1
T0997	0-2000N.m	1"	1620.0mm	1

TORQUE WRENCH

1/4" 3/8"



- Made of steel alloy, 50 teeth
- Flat design, apply to narrow space
- Warning at the predetermined torque value
- Push and pull structure, easy to use
- Maximum erroneous precision:3%
- Meet ASME B107.4

PART #	SIZE	DRIVER	LENGTH	
E0910	1-5Nm	1/4"	270.0mm	1
E0918	5-25Nm	3/8"	270.0mm	1
E0919	10-50Nm	3/8"	270.0mm	1

TORQUE WRENCH

1/2"



- Made of steel alloy, 50 teeth
- Flat design, apply to narrow space
- Warning at the predetermined torque value
- Push and pull structure, easy to use
- Maximum erroneous precision:3%
- Meet ASME B107.4

PART #	SIZE	DRIVER	LENGTH	
E0916	25-125Nm	1/2"	380.0mm	1
E0917	10-50Nm	1/2"	380.0mm	1
E0920	20-100Nm	1/2"	380.0mm	1
E0926	40-200Nm	1/2"	500.0mm	1
E0927	60-300Nm	1/2"	690.0mm	1
E0928	70-340Nm	1/2"	690.0mm	1

TORQUE WRENCH

3/4"



- Made of steel alloy, 50 teeth
- Flat design, apply to narrow space
- Warning at the predetermined torque value
- Push and pull structure, easy to use
- Maximum erroneous precision:3%
- Meet ASME B107.4

PART #	SIZE	DRIVER	LENGTH	
E0940	100-500Nm	3/4"	940.0mm	1
E0944	200-1000Nm	3/4"	1200.0mm	1
E0945	160-800Nm	3/4"	1200.0mm	1

Digimatic Torque Adapter 40-200Nm.



- Accuracy: ±2%
- Two Mode: peak data hold and real time display
- Beeper and LED indicator light on when reaches preset torque
- Unit switch among KG-CM, KG-M, FT-LB, IN-LB and N-M
- Rotatable mechanism can get total 240° view area to read information shown on the LCD display easily
- Display direction can be toggled to read torque information easily
- Target torque can be shown in using
- No activity detected for 3 minutes will automatically enter sleep mode to save battery power

PART #	SIZE	DRIVER	LENGTH	
T0970	40-200Nm	1/2"	1	1

TORQUE ANGLE GAUGES



PART #	SIZE	
E0753	1/2"	6

Torque Angle Gauges (magnetic)



PART #	LENGTH	
E0754	1/2"	6

DIGIMATIC TORQUE WRENCH



- Comfortable PP+TPR handle
- Full enclosed ratchet head to extend life Forward and reverse usage
- LCD display, engineering units selectable: N-M,IN-LB, FT-LB and KG-CM
- Track mode & peak hold mode selectable Buzzer & LED indication for pre-settable target torque
- Forward accuracy:±2%
- Reverse accuracy:±3%

PART #	SIZE	DRIVER	LENGTH	
E0010	1.5-30Nm	1/4"	390.0mm	1
E0013	6.8-135Nm	3/8"	415.0mm	1
E0016	6.8-135Nm	1/2"	415.0mm	1
E0017	10-200Nm	1/2"	530.0mm	1
E0018	17-340Nm	1/2"	650.0mm	1

DIGIMATIC TORQUE WRENCH



- Comfortable PP+TPR handle
- Full enclosed ratchet head to extend life Forward and reverse usage
- LCD display, engineering units selectable: N-M,IN-LB, FT-LB and KG-CM
- Track mode & peak hold mode selectable Buzzer & LED indication for pre-settable target torque
- Forward accuracy:±2%
- Reverse accuracy:±3%

PART #	SIZE	DRIVER	LENGTH	
E0019	25-500Nm	3/4"	950.0mm	1
E0020	42.5-850Nm	3/4"	1220.0mm	1
E0021	60-1200Nm	1"	1800.0mm	1
E0022	75-1500Nm	1"	1800.0mm	1
E0023	100-2000Nm	1"	1800.0mm	1

DIGIMATIC TORQUE WRENCH



- Comfortable PP+TPR handle
- LCD display, engineering units selectable: N-M,IN-LB, FT-LB and KG-CM
- Track mode & peak hold mode selectable Buzzer & LED indication for pre-settable target torque
- Forward accuracy:±2%
- Reverse accuracy:±3%

PART #	SIZE	DRIVER	LENGTH	
E0046	1.5-30Nm	9x12mm	390.0mm	1
E0047	6.8-135Nm	9x12mm	410.0mm	1
E0048	10-200Nm	14x18mm	545.0mm	1
E0049	17-340Nm	14x18mm	640.0mm	1

MINI DIGIMATIC TORQUE WRENCH



- Comfortable PP+TPR handle
- Full enclosed ratchet head to extend life Forward and reverse usage
- LCD display, engineering units selectable: N-M,IN-LB, FT-LB and KG-CM
- Track mode & peak hold mode selectable Buzzer & LED indication for pre-settable target torque
- Forward accuracy:±3%
- Reverse accuracy:±4%

PART #	SIZE	DRIVER	LENGTH	
E0026	0.3-6Nm	1/4"	207.0mm	1
E0027	0.6-12Nm	1/4"	207.0mm	1
E0028	1-20Nm	1/4"	207.0mm	1
E0029	1.5-30Nm	1/4"	207.0mm	1
E0030	3-60Nm	3/8"	207.0mm	1
E0031	4.2-85Nm	3/8"	207.0mm	1

MINI DIGIMATIC TORQUE WRENCH(BITS)



- Comfortable PP+TPR handle
- Full enclosed ratchet head to extend life Forward and reverse usage
- LCD display, engineering units selectable: N-M,IN-LB, FT-LB and KG-CM
- Track mode & peak hold mode selectable Buzzer & LED indication for pre-settable target torque
- Forward accuracy:±3%
- Reverse accuracy:±4%

PART #	SIZE	DRIVER	LENGTH	
E0035	0.3-6Nm	1/4"	207.0mm	1
E0036	0.6-12Nm	1/4"	207.0mm	1
E0037	1-20Nm	1/4"	207.0mm	1

DIGIMATIC TORQUE SCREWDRIVER



- Comfortable PP+TPR handle
- LCD display, engineering units selectable: N-M,IN-LB, FT-LB and KG-CM
- Track mode & peak hold mode selectable Buzzer & LED indication for pre-settable target torque
- Forward accuracy:±2.5%
- Reverse accuracy:±3.5%

PART #	SIZE	DRIVER	LENGTH	
E0041	5-50cNm	1/4"	193.0mm	1
E0042	10-200cNm	1/4"	203.0mm	1
E0043	20-400cNm	1/4"	203.0mm	1



10

INSULATED TOOLS

INSULATED SCREWDRIVER SLOTTED



1000V

- GS, CE Approved for High-Pot 1000V Test
- Insulated blade made in Cr-V Steel
- Blade Heat Treated

PART #	SIZE	LENGTH	NEW
E6481	2.5X75mm	154.0mm	12
E6482	4.0X100mm	188.0mm	12
E6483	5.0X125mm	213.0mm	12
E6484	6.5X150mm	248.0mm	12

INSULATED SCREWDRIVER SLOTTED

Updated



1000V

- Blade made of S2.
- Two tone of TPR handle.
- Full heat treated, durable.

PART #	SIZE	LENGTH	NEW
E6486	2.5x75mm	154.0mm	12
E6490	3.0x100mm	273.0mm	12 NEW
E6495	3.5x100mm	273.0mm	12 NEW
E6487	4.0x100mm	188.0mm	12
E6488	5.5x125mm	213.0mm	12
E6489	6.5x150mm	248.0mm	12

7PC. INSULATED SCREWDRIVER



1000V

4-Screwdriver slotted 2.5X75,4.0X100,5.0X125,6.5X150mm
3-Screwdriver phillips #0X75,#1X80,#2X100mm

- Blade Made of Cr -V.

PART #	CONTENTS	ΔTΔ	NEW
E1168	7PCS	0.58kg	6

INSULATED SCREWDRIVER PHILLIPS



1000V

- GS, CE Approved for High-Pot 1000V Test
- Insulated blade made in Cr-V Steel
- Blade Heat Treated

PART #	SIZE	LENGTH	NEW
E6491	#0X75mm	154.0mm	12
E6492	#1X80mm	168.0mm	12
E6493	#2X100mm	198.0mm	12

INSULATED SCREWDRIVER PHILLIPS



1000V

- Blade made of S2.
- Two tone of TPR handle.
- Full heat treated, durable.

PART #	SIZE	LENGTH	NEW
E6496	PH0x60mm	154.0mm	12
E6497	PH1x80mm	168.0mm	12
E6498	PH2x100mm	198.0mm	12
E6499	PH3x150mm	323.0mm	12 NEW

7PC INSULATED SCREWDRIVER



1000V

4 pcs.- Slotted 2.5X75,4.0X100,5.5X125,6.5X150mm
3 pcs.- Phillips #0X60,#1X80,#2X100mm

- Blade made of S2, double color TPR handle.

PART #	CONTENTS	ΔTΔ	NEW
E1169	7PCS	0.6kg	6

10PC INSULATED TOOLS SET



1000V

- 3 pcs.- Slotted 2.5x75,4.0x100,5.5x125mm
- 2 pcs.- Phillips #1x80, #2x100mm
- 4 pcs.- Lineman's Plier, Long Nose Plier, Diagonal Plier, Insulated Tape
- 1 pcs.- VDE Voltage Tester

PART #	CONTENTS	ΔTΔ	NEW
E1170	10PCS	1.7kg	6



INSULATED TOOL

VDE INSULATED LINEMAN'S PLIER



▲ 1000V

- Made of Cr-V.

PART #	SIZE	LENGTH	
E5361	6"	150.0mm	6
E5362	7"	175.0mm	6
E5363	8"	200.0mm	6

VDE INSULATED DIAGONAL PLIER



▲ 1000V

- Made of Cr-V.

PART #	SIZE	LENGTH	
E5381	6"	150.0mm	6
E5383	7"	175.0mm	6

VDE INSULATED GROOVE JOINT PLIER



▲ 1000V

- Made of Cr-V.

PART #	SIZE	LENGTH	
E5398	10"	250.0mm	6



VDE INSULATED BENT NOSE PLIER



▲ 1000V

- Made of Cr-V.

PART #	SIZE	LENGTH	
E5391	6"	150.0mm	6
E5392	8"	200.0mm	6

VDE INSULATED TAPE



▲ 1000V

PART #	COLOR	
E9725	RED	50

VDE INSULATED LONG NOSE PLIER



▲ 1000V

- Made of Cr-V.

PART #	SIZE	LENGTH	
E5371	6"	150.0mm	6
E5372	8"	200.0mm	6

VDE INSULATED WIRE STRIPPER



▲ 1000V

- Made of Cr-V.

PART #	SIZE	LENGTH	
E5396	6"	150.0mm	6

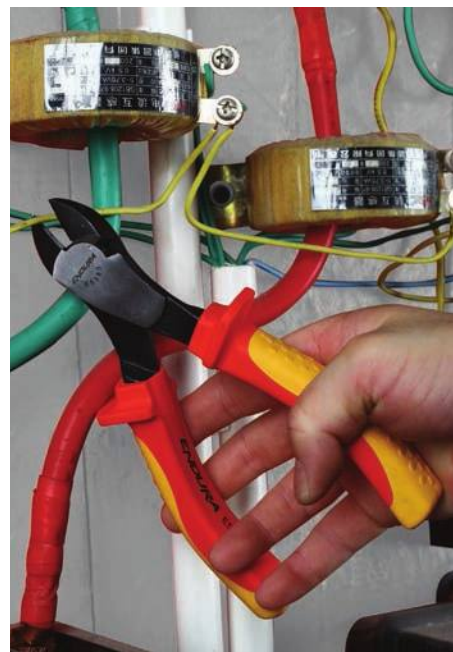

VDE INSULATED NUT DRIVER SCREWDRIVERS



▲ 1000V

- Double color TPR handle
- Blade made of S2, heat treated
- IEC60900

PART #	SIZE	LENGTH	
E6444	4.0x125mm	230mm	12
E6445	5.0x125mm	230mm	12
E6446	5.5x125mm	230mm	12
E6447	6.0x125mm	230mm	12
E6448	7.0x125mm	230mm	12
E6449	8.0x125mm	230mm	12
E6450	9.0x125mm	230mm	12
E6471	10x125mm	230mm	12
E6472	11x125mm	243mm	12
E6473	12x125mm	243mm	12
E6474	13x125mm	243mm	12
E6475	14x125mm	243mm	12

VDE INSULATED OPEN END WRENCHES



▲ 1000V

- Made of CR-V, heat treated
- Rust-proof
- Double color TPR handle
- IEC60900

PART #	SIZE	LENGTH	
E2920	6mm	89.5mm	6
E2921	7mm	89.9mm	6
E2922	8mm	99.5mm	6
E2923	9mm	99.5mm	6
E2924	10mm	110mm	6
E2925	11mm	120mm	6
E2926	12mm	130mm	6
E2927	13mm	140mm	6
E2928	14mm	150mm	6
E2929	15mm	160mm	6
E2930	16mm	165mm	6
E2931	17mm	165mm	6
E2932	18mm	175mm	6
E2933	19mm	180mm	6
E2934	21mm	195mm	6
E2935	22mm	205mm	6
E2936	24mm	230mm	6
E2937	27mm	250mm	4
E2938	30mm	285mm	4
E2939	32mm	308mm	4

VDE INSULATED BOX WRENCHES



▲ 1000V

- Made of CR-V, heat treated
- Rust-proof
- Double color TPR handle
- IEC60900

PART #	SIZE	LENGTH	
E2960	6mm	130mm	6
E2961	7mm	140mm	6
E2962	8mm	150mm	6
E2963	9mm	160mm	6
E2964	10mm	170mm	6
E2965	11mm	180mm	6
E2966	12mm	190mm	6
E2967	13mm	200mm	6
E2968	14mm	210mm	6
E2969	15mm	215mm	6
E2970	16mm	215mm	6
E2971	17mm	220mm	6
E2972	18mm	230mm	6
E2973	19mm	240mm	6
E2974	21mm	250mm	6
E2975	22mm	260mm	6
E2976	24mm	280mm	6
E2977	27mm	290mm	4
E2978	30mm	310mm	4
E2979	32mm	320mm	4

VDE INSULATED ADJUSTABLE WRENCHES



▲ 1000V

- Made of CR-V, heat treated
- Rust-proof
- Double color TPR handle
- IEC60900

PART #	SIZE	LENGTH	
E2051	8"	200mm	6
E2052	10"	250mm	6
E2053	12"	300mm	6

VDE INSULATED CABLE CUTTERS



▲ 1000V

- Made of CR-V, heat treated
- Rust-proof
- Double color TPR handle
- IEC60900

PART #	SIZE	LENGTH	
E5401	6"	150mm	6

VDE INSULATED CABLE CUTTERS



▲ 1000V

- Made of CR-V, heat treated
- Rust-proof
- Double color TPR handle
- IEC60900

PART #	SIZE	LENGTH	
E5402	10"	250mm	6

VDE CABLE KNIVES





- Stainless steel knife
- Double color TPR handle
- IEC60900

PART #	BLADE LENGTH	LENGTH	
E7029	50mm	180mm	6

VDE CABLE KNIVES





- Stainless steel knife
- Double color TPR handle
- IEC60900

PART #	BLADE LENGTH	LENGTH	
E7030	28mm	155mm	6

VDE CABLE KNIVES





- Stainless steel knife
- Double color TPR handle
- IEC60900

PART #	刀片长	LENGTH	
E7031	50mm	180mm	6

VDE CABLE KNIVES





- Stainless steel knife
- Double color TPR handle
- IEC60900

PART #	BLADE LENGTH	LENGTH	
E7032	50mm	180mm	6

VDE CABLE KNIVES





- Stainless steel knife
- Double color TPR handle
- IEC60900

PART #	BLADE LENGTH	LENGTH	
E7033	38mm	155mm	6

VDE CABLE KNIVES





- Stainless steel knife
- Double color TPR handle
- IEC60900

PART #	BLADE LENGTH	LENGTH	
E7034	58mm	185mm	6

VDE INSULATED CABLE BLADES





- Stainless steel knife
- Double color TPR handle
- IEC60900

PART #	BLADE LENGTH	LENGTH	
E7035	58mm	80mm	6

INSULATED PLASTIC CLAMP





- Insulated PP
- IEC60900

PART #	LENGTH	
E9738	150mm	6

INSULATED PLASTIC FLAT NOSE PLIER





- Insulated PP
- IEC60900

PART #	LENGTH	
E9739	200mm	6

VDE INSULATED PRECISION TWEEZERS





- IEC60900

PART #	LENGTH	
E9718	130mm	6

VDE INSULATED PRECISION TWEEZERS







- IEC60900

PART #	LENGTH	
E9720	150mm	6

VDE INSULATED RATCHETING CABLE CUTTERS





- IEC60900

PART #	CUTTING DIAM.	LENGTH	
E5403	32mm(240mm²)	240mm	1
E5404	52mm(380mm²)	330mm	1

VDE INSULATED PRECISION TWEEZERS





- IEC60900

PART #	LENGTH	
E9719	150mm	6

VDE INSULATED JUNIOR HACKSAW







- IEC60900

PART #	SIZE	LENGTH	
E7057	150mm	300mm	6

VDE INSULATED HEX KEY





- Made of Cr-V, heat treated
- Rust-proof
- Double color TPR handle
- IEC60900

PART #	SIZE	LENGTH	
E7501	3mm	130mm	6
E7502	4mm	140mm	6
E7503	5mm	160mm	6
E7504	6mm	180mm	6
E7505	8mm	200mm	6
E7506	10mm	235mm	6
E7507	12mm	260mm	6

VDE INSULATED PRECISION TWEEZERS





- IEC60900

PART #	LENGTH	
E9727	142mm	6

VDE VOLTAGE TESTERS





- S2 blade, rust-proof
- PS handle
- 30,000times working life
- volt : 125-250V

PART #	SIZE	LENGTH	
E5408	125-250V	145mm	12

VDE INSULATED CABLE CUTTERS





- Made of Cr-V, heat treated
- High hardness
- Two tone insulated handle, comfortable
- IEC60900

PART #	SIZE	LENGTH	
E5405	250mm²	610mm	1
E5406	500mm²	810mm	1

INSULATED TOOL

INSULATED TOOL

12PCS VDE INSULATED SCREWDRIVERS SET



- 2.0,2.5,3.0,3.5,4.0,5.5,6.5mm
- PH0x100,PH1x100,PH2x100
- Voltage Tester : 1pc
- Handle : 1pc
- S2 blade,heat treated
- IEC60900

PART #	CONTENTS	ΔTΔ	📦
E1174	12PCS	0.41kg	1

16PCS 3/8" DR. VDE INSULATED SOCKETS SET



- 8pcs-Insulated Metric Sockets 8,10,11,12,13,14,17,19mm
- 1pc-Insulated ratchet wrench
- 2pcs-Insulated extension bar 125,250mm
- 1pc-Insulated T-handle wrench
- 4pcs-Insulated bits,hex 4,5,6,8mm
- Made of CR-V,heat treated
- IEC60900

PART #	CONTENTS	ΔTΔ	📦
E1176	16PCS	2.69kg	1

VDE INSULATED SCISSOR



- Scissor made of stainless steel, sharp
- Two tone insulated handle, comfortable
- IEC60900

PART #	SIZE	LENGTH	📦
E7036	6"	160mm	6

VDE INSULATED BOLT CUTTER

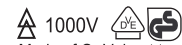

- Made of CR-V, heat treated
- High hardness
- Two tone insulated handle, comfortable
- IEC60900

PART #	SIZE	LENGTH	📦
E5407	24"	600	1

INSULATED BOX GEARTECH WRENCH



- Made of CR-V, heat treated
- Handle with insulated cover
- IEC60900

PART #	SIZE	📦
E2740	10mm	6
E2741	11mm	6
E2742	12mm	6
E2743	13mm	6
E2744	14mm	6
E2745	15mm	6
E2746	16mm	6
E2747	17mm	6
E2748	18mm	6
E2749	19mm	6

50PCS VDE INSULATED SCREWDRIVERS SET



- 2.0,2.5,3.0,3.5,4.0,5.5,6.5mm
- PH0x100,PH1x100,PH2x100
- PZ0,PZ1,PZ2
- T6,T8,T9,T10,T15,T20,T25,T27,T30
- H2.5,H3.0,H4.0,H5.0,H6.0
- R1,R2
- TR1,TR2,TR3,TR4
- TORO4,TORO6,TORO8,TORO10
- M4,M5,M6
- 4,6,8,10
- 6,3,8,1
- 1pc
- 1pc
- Voltage tester :1pc
- Handle:1pc
- Blade made of S2,heat treated
- IEC60900

PART #	CONTENTS	ΔTΔ	📦
E1175	50PCS	1.34kg	1

20PCS 1/2" DR. VDE INSULATED SOCKETS SET



- 11pcs-Insulated Metric Sockets 10,11,12,13,14,17,19,22,24,27,30,32mm
- 1pc-Insulated ratchet wrench
- 2pcs-Insulated extension bar 125,250mm
- 1pc-Insulated T-handle wrench
- 5pcs-Insulated bits,hex 4,5,6,8,10mm
- Blade made of CR-V,heat treated
- IEC60900

PART #	CONTENTS	ΔTΔ	📦
E1177	20PCS	4.67kg	1

16PCS VDE INSULATED TOOLS SET



- 7 pcs-VDE Insulated Open End Wrench 10,11,12,13,14,17,19cm
- 1 pcs-VDE Insulated Lineman's Plier 8"
- 1 pcs-VDE Insulated Long Nose Plier 8"
- 1 pcs-VDE Voltage Tester
- 3 pcs-VDE Insulated Screwdriver Slotted 4.0x100mm, 5.0x100mm,6.5x100mm S2 blade
- 2 pcs-VDE Insulated Screwdriver Phillips No.1x80mm, No.2x100mmS2 blade
- 1 pcs-VDE Insulated Cable Knife
- Made of CR-V, heat treated
- IEC60900

PART #	CONTENTS	ΔTΔ	📦
E1179	16PCS	3.10kg	1

19PCS VDE INSULATED TOOLS SET



- 1 pcs-1/2" Dr. VDE Insulated Reversible Ratchet Wrench 250mm
- 7 pcs-1/2" Dr. VDE Insulated Sockets 10,11,12,13,14,17,19mm
- 2 pcs-1/2" Dr. VDE Insulated Extension Bar 125mm,250mm
- 1 pcs-VDE Insulated Lineman's Plier 8"
- 1 pcs-VDE Insulated Diagonal Plier 6"
- 3 pcs-VDE Insulated Screwdriver Slotted 3.5x100mm, 4.0x100mm,5.0x100mm S2 blade
- 2 pcs-VDE Insulated Screwdriver Phillips No.1x80mm, No.2x100mm S2 blade
- 1 pcs-VDE Insulated Cable Knife
- 1 pcs-VDE Voltage Tester
- Made of CR-V, heat treated
- IEC60900

PART #	CONTENTS	ΔTΔ	📦
E1180	19PCS	4.26kg	1

21PCS VDE INSULATED TOOLS SET



- 1 pcs-1/2" Dr. VDE Insulated Reversible Ratchet Wrench 250mm
- 7 pcs-1/2" Dr. VDE Insulated Sockets 10,11,12,13,14,17,19mm
- 1 pcs-1/2" Dr. VDE Insulated Extension Bar 125mm
- 1 pcs-VDE Insulated Lineman's Plier 8"
- 1 pcs-VDE Insulated Diagonal Plier 6"
- 1 pcs-VDE Voltage Tester
- 3 pcs-VDE Insulated Nut Driver 6.0x125mm,7.0x125mm, 8.0x125mm
- 3 pcs-VDE Insulated Screwdriver Slotted 3.5x100mm, 4.0x100mm,5.0x100mm S2 blade
- 2 pcs-VDE Insulated Screwdriver Phillips No.1x80mm, No.2x100mm S2 blade
- 1 pcs-VDE Insulated Cable Knife
- Made of CR-V, heat treated
- IEC60900

PART #	CONTENTS	ΔTΔ	📦
E1181	21PCS	4.12kg	1

25PCS VDE INSULATED TOOLS SET

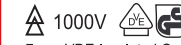

- 7 pcs-VDE Insulated Open End Wrench 10,11,12,13,14,17,19cm
- 7 pcs-1/2" Dr. VDE Insulated Sockets 10,11,12,13,14,17,19mm
- 1 pcs-1/2" Dr. VDE Insulated T-handle Wrench 200mm
- 1 pcs-VDE Insulated Lineman's Plier 8"
- 1 pcs-VDE Insulated Diagonal Plier 6"
- 1 pcs-VDE Voltage Tester
- 4 pcs-VDE Insulated Screwdriver Slotted 2.5x75mm,3.5x100mm, 4.0x100mm,5.0x125mm S2 blade
- 2 pcs-VDE Insulated Screwdriver Phillips No.1x80mm, No.2x100mm S2 blade
- 1 pcs-VDE Insulated Cable Knife
- Made of CR-V, heat treated
- IEC60900

PART #	CONTENTS	ΔTΔ	📦
E1182	25PCS	4.0kg	1

11PCS VDE INSULATED TOOLS SET



- 1 pcs-VDE Insulated Adjustable Wrench 10"
- 1 pcs-VDE Insulated Lineman's Plier 8"
- 1 pcs-VDE Insulated Long Nose Plier 6"
- 1 pcs-VDE Insulated Diagonal Plier 6"
- 1 pcs-VDE Voltage Tester
- 3 pcs-VDE Insulated Screwdriver Slotted 4.0x100mm, 5.0x100mm,6.5x100mm S2 blade
- 2 pcs-VDE Insulated Screwdriver Phillips No.1x80mm, No.2x100mm S2 blade
- 1 pcs-VDE Insulated Cable Knife
- Made of CR-V, heat treated
- IEC60900

PART #	CONTENTS	ΔTΔ	📦
E1178	11PCS	3.59kg	1

3PC.VDE INSULATED PLIERS SET



- 1pc-Insulated lineman's plier 8"
- 1pc-Insulated diagonal plier 6"
- 1pc-Insulated long nose plier 6"
- Made of CR-V

PART#	CONTENTS	ΔTΔ	📦
E1188	3	0.7kg	1

VDE INSULATED REVERSIBLE RATCHET WRENCH



- Made of CR-V,heat treated
- 72 teeth
- Double color TPR handle
- Reversible
- IEC60900

PART #	SIZE	LENGTH	📦
E2548	10mm	200mm	4
E2549	12.5mm	250mm	4

VDE INSULATED TORQUE WRENCH



- 50 teeth
- New design, durable,
- Clear "click" alarm to fixed torque
- Maximum erroneous precision:3%
- Double color TPR handle
- IEC60900

PART#	SIZE	DRIVER	LENGTH	📦
E0083	5-25N.m	3/8"	288mm	1
E0084	5-50N.m	3/8"	288mm	1
E0087	5-25N.m	1/2"	288mm	1
E0088	5-50N.m	1/2"	288mm	1

VDE INSULATED EXTENSION BAR



- Made of CR-V, heat treated
- IEC60900

PART #	SIZE	LENGTH	📦
E3419	10x125mm	125mm	4
E3420	10x250mm	250mm	4
E4539	12.5x125mm	125mm	4
E4540	12.5x250mm	250mm	4

3/8" DR.VDE INSULATED SOCKET



1000V

- Made of Cr-V, heat treated
- Rust-proof IEC60900

PART #	SIZE	LENGTH	
E3378	8mm	44mm	6
E3380	10mm	44mm	6
E3381	11mm	44mm	6
E3382	12mm	44mm	6
E3383	13mm	44mm	6
E3384	14mm	44mm	6
E3386	16mm	44mm	6
E3387	17mm	44mm	6
E3388	18mm	44mm	6
E3389	19mm	44mm	6
E3391	21mm	44mm	6
E3392	22mm	44mm	6

4-WAY VDE INSULATED SOCKET WRENCH



1000V

- Made of Cr-V, heat treated IEC60900

PART #	SIZE	
E4595	10x12x14x17mm	6
E4596	10x13x14x17mm	6
E4597	13x14x17x19mm	6

VDE INSULATED PEAD BELOW HAMMER



1000V

- EXCHANGEABLE PU HEAD WITH STEEL GRID FILLINGS IEC60900

PART #	SIZE	
E7260	30mm	6

12.5mmDr. VDE INSULATED SOCKET



1000V

- Made of Cr-V, heat treated
- Rust-proof IEC60900

PART #	SIZE	LENGTH	
E3810	10mm	54mm	6
E3811	11mm	54mm	6
E3812	12mm	54mm	6
E3813	13mm	54mm	6
E3814	14mm	54mm	6
E3816	16mm	54mm	6
E3817	17mm	54mm	6
E3818	18mm	54mm	6
E3819	19mm	54mm	6
E3821	21mm	54mm	6
E3822	22mm	54mm	6
E3824	24mm	54mm	6
E3827	27mm	54mm	4
E3830	30mm	54mm	4
E3832	32mm	54mm	4

VDE INSULATED T-HANDLE WRENCH



1000V

- Made of Cr-V, heat treated
- Double color TPR handle IEC60900

PART #	SIZE	LENGTH	
E3421	10mm	200mm	4
E4534	12.5mm	200mm	4

VDE INSULATED CONSTRUCTION WRENCH



1000V

- Made of Cr-V, heat treated IEC60900

PART #	SIZE	
E2732	13x17mm	4
E2735	17x19mm	4
E2737	19x24mm	4



PNEUMECTIC TOOLS

3/8"Dr.6PT DEEP IMPACT SOCKET



- made of steel alloy,cold-forging technology
- meet and exceed ANSI B107.5-1994 & DIN899-1980

PART #	SIZE	LENGTH	QTY
E4753	8mm	63.0mm	12
E4754	9mm	63.0mm	12
E4755	10mm	63.0mm	12
E4756	11mm	63.0mm	12
E4757	12mm	63.0mm	12
E4758	13mm	63.0mm	12
E4759	14mm	63.0mm	12
E4760	15mm	63.0mm	12
E4761	16mm	63.0mm	12
E4762	17mm	63.0mm	12
E4763	18mm	63.0mm	12
E4764	19mm	63.0mm	12

1/2"Dr.6PT.IMPACT SOCKET



- made of steel alloy,cold-forging technology
- meet and exceed ANSI B107.5-1994 & DIN899-1980

PART #	SIZE	LENGTH	QTY
E4811	10mm	37.8mm	12
E4812	11mm	37.8mm	12
E4813	12mm	37.8mm	12
E4814	13mm	37.8mm	12
E4815	14mm	37.8mm	12
E4816	15mm	37.8mm	12
E4817	16mm	37.8mm	12
E4818	17mm	37.8mm	12
E4819	18mm	37.8mm	12
E4820	19mm	37.8mm	12
E4821	21mm	37.8mm	12
E4822	22mm	40.0mm	12
E4823	24mm	40.0mm	12
E4824	27mm	43.0mm	12
E4825	30mm	43.0mm	12
E4826	32mm	43.0mm	12

UNIVERSAL JOINT



- made of steel alloy,cold-forging technology
- meet and exceed ANSI B107.5-1994 & DIN899-1981

PART #	DRIVER	QTY
E4875	1/2"	12

UNIVERSAL JOINT



- made of steel alloy,cold-forging technology
- meet and exceed ANSI B107.5-1994 & DIN899-1981

PART #	DRIVER	MALE	QTY
E4873	1/2"	3/4"	12
E4874	1/2"	3/8"	12

EXTENTION BAR



- made of steel alloy,cold-forging technology
- meet and exceed ANSI B107.5-1994 & DIN899-1981

PART #	DRIVER	LENGTH	QTY
E4871	1/2"	150.0mm	12
E4872	1/2"	250.0mm	12

3/4"Dr.6PT IMPACT SOCKET



- made of steel alloy,cold-forging technology
- meet and exceed ANSI B107.5-1994 & DIN899-1981

PART #	SIZE	LENGTH	QTY
E4903	19mm	51.0mm	4
E4904	20mm	51.0mm	4
E4905	21mm	51.0mm	4
E4906	22mm	51.0mm	4
E4908	24mm	51.0mm	4
E4911	27mm	53.0mm	4
E4914	30mm	53.0mm	4
E4916	32mm	57.0mm	4
E4918	34mm	57.0mm	4
E4920	36mm	57.0mm	4
E4922	38mm	57.0mm	4
E4925	41mm	58.0mm	4
E4926	42mm	58.0mm	3
E4930	46mm	62.0mm	3
E4934	50mm	62.0mm	3
E4937	55mm	71.0mm	3
E4942	60mm	73.0mm	3
E4944	65mm	73.0mm	3

IMPACT ADAPTOR



- made of steel alloy,cold-forging technology
- meet and exceed ANSI B107.5-1994 & DIN899-1981

PART #	DRIVER	MALE	QTY
E4888	3/4"	1/2"	6

3/4" DR EXTENTION BAR



- made of steel alloy,cold-forging technology
- meet and exceed ANSI B107.5-1994 & DIN899-1981

PART #	DRIVER	LENGTH	QTY
E4882	3/4"	100.0mm	6
E4883	3/4"	150.0mm	6
E4885	3/4"	200.0mm	4
E4886	3/4"	250.0mm	4

3/4"Dr.6PT DEEP IMPACT SOCKET



- made of steel alloy,cold-forging technology
- meet and exceed ANSI B107.5-1994 & DIN899-1981

PART #	SIZE	LENGTH	QTY
E4953	19mm	90.0mm	4
E4955	21mm	90.0mm	4
E4956	22mm	90.0mm	4
E4958	24mm	90.0mm	4
E4961	27mm	90.0mm	4
E4964	30mm	90.0mm	4
E4966	32mm	90.0mm	4
E4968	34mm	90.0mm	4
E4970	36mm	90.0mm	4
E4974	41mm	90.0mm	4
E4979	46mm	90.0mm	3
E4983	50mm	90.0mm	3
E4984	55mm	100.0mm	3



UNIVERSAL JOINT

3/4"



- made of steel alloy, cold-forging technology
- meet and exceed ANSI B107.5-1994 & DIN899-1981

PART #	DRIVER	LENGTH	
E4890	3/4"	111.0mm	6

BLOWING DUST GUN



- copper sprayer, Rust-proof
- nylon Handle, good performance
- copper gas seal, size: 1/4" 19NPT
- Working pressure: 5.0-8.0KGF/CM2

PART #	SIZE	
E8551	100mm	10

BLOWING DUST GUN



- copper sprayer, Rust-proof
- nylon Handle, good performance
- copper gas seal, size: 1/4" 19NPT
- Working pressure: 5.0-8.0KGF/CM3

PART #	SIZE	
E8552	250mm	10

whole series of pneumatic tools is coming soon.

pneumatic impact wrench: 3/8", 1/2", 3/4", 1"



pneumatic Ratchet Wrench Kit: 1/2"

pneumatic screwdriver

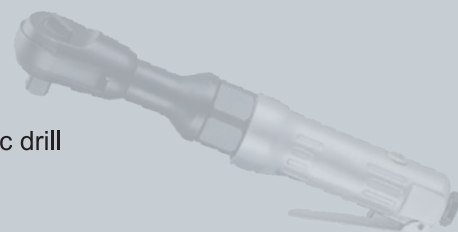

pneumatic drill

pneumatic angle grinder

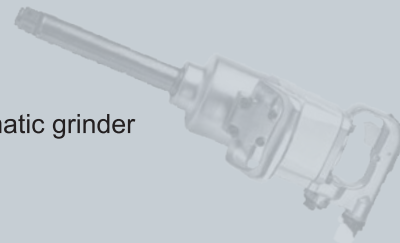

pneumatic grinder

pneumatic chipping hammers

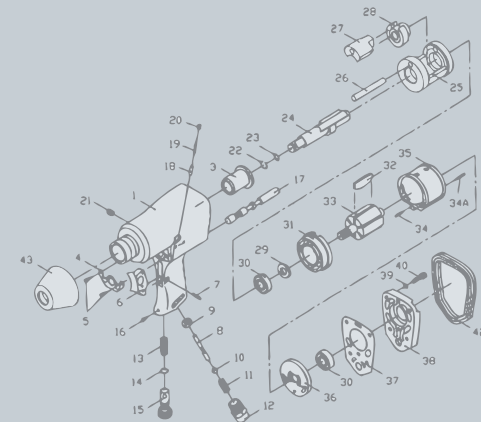

12

WOKESHOP EQUIPMENTS

MINI 2-ARM PULLER



- Full forged with triangle screw thread design.

PART #	REACH	SPREAD	SIZE
E0131	40mm	60mm	12
E0132	65mm	65mm	12
E0133	80mm	80mm	12

CR-V 3-JAW GEAR PULLER



- Heavy duty. Made of Cr-V.
- All parts heat-treated for durability. Convenient to use.

PART #	SPREAD	SIZE
E0181	15-80mm	3"
E0182	20-110mm	4"
E0183	25-160mm	6"
E0184	30-210mm	8"
E0186	50-310mm	12"

PROFESSIONAL VISE WITH ANVIL



- High precision
- Reinforced and durable base
- Greater tense strength
- Multi functions

PART #	SIZE	JAWOPENING	ΔTΔ
E0114	4"	102mm	9kg
E0115	5"	127mm	13kg
E0116	6"	152mm	19kg
E0117	7"	170mm	25kg

CR-V 2-JAW GEAR PULLER



- Heavy duty. Made of Cr-V.
- All parts heat-treated for durability. Convenient to use.

PART #	SPREAD	SIZE
E0171	15-80mm	3"
E0172	20-110mm	4"
E0173	25-160mm	6"
E0174	30-210mm	8"
E0176	50-310mm	12"

PIPE VISE



- Full forged ,heat treatment.

PART #	SIZE	REACH
E0121	2"	60mm
E0122	3"	90mm

PROFESSIONAL VISE WITH ANVIL



- Full heat treatment
- Heavy duty. Made of Cr-V.

PART #	SIZE	JAWOPENING	ΔTΔ
E0119	9"	205mm	48kg

MINI 3-ARM PULLER



- Full forged with triangle screw thread design.

PART #	REACH	SPREAD
E0146	40mm	60mm
E0147	65mm	65mm
E0148	80mm	80mm

HYDRAULIC PULLER



- Disassemble and foldable Handle
- Long handle for easy operation
- 360o Adjustable Hydraulic Nozzle
- Quick Release Switch for Hydraulic Control
- With Internal Safety Valve, to Avoid Overload
- Special Alloy Steel, Forged Claws
- Special Design for Claw Tip for Stable Holding
- Dust Prevention Treatment for Claws
- Optional 2 or 3 Claw Seat

PART #	SIZE	REACH	SPREAD
E0188	6TON	220mm	330mm

HYDRAULIC PULLER



- Disassemble and foldable Handle
- Long handle for easy operation
- 360o Adjustable Hydraulic Nozzle
- Quick Release Switch for Hydraulic Control
- With Internal Safety Valve, to Avoid Overload
- Special Alloy Steel, Forged Claws
- Special Design for Claw Tip for Stable Holding
- Dust Prevention Treatment for Claws
- Optional 2 or 3 Claw Seat

PART #	SIZE	SPREAD	REACH
E0189	12TON	270mm	375mm

HEAVY DUTY C-CLAMP

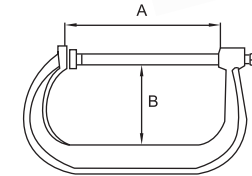

- High-quality steel, full forged.
- Structure design of strengthening, resistance to bending and distorting.
- Special structure of hex on the top of screw, more suitable for adding force
- T threaded screw have higher strength.

PART #	SIZE	A	B
E0161	2"	69	54
E0162	3"	96	63
E0163	4"	125	83
E0164	6"	176	105
E0165	8"	227	128

PROFESSIONAL VISE WITH ANVIL



- Precision casting, nice appearance
- jaw made of NO.45 steel,Heat treatment,HRC48-52
- can rotate 360 degree,easy operation
- Size:107mm deep,90×100mm about:Ø17-88.5mm
- Force:30KN

PART #	SIZE	JAWOPENING	ΔTΔ
E0126	6"	178mm	25kg

STAUBKESSE STEEL SCRAPER



- Stainless blade, sharp, wear-resistant
- Special blade edge treatment, not hurt
- surface of workpiece
- Red wood handle, comfortable

PART #	SIZE	LENGTH
E9840	10mm	165mm
E9841	15mm	172mm
E9842	23mm	178mm

PROFESSIONAL VISE WITH ANVIL



- Heavy duty. Jaw is made of alloy.

PART #	SIZE	LENGHT
E0151	4"	100.0mm

MINI 3-ARM PULLER



- Full forged with triangle screw thread design

PART #	SPREAD	REACH
E0136	40mm	60mm
E0137	65mm	65mm
E0138	80mm	80mm



PRECISION TOOL

13

PRECISION TOOLS



6mm LCD Screen for Easy Reading

Made of Stainless Steel, Matt Finished

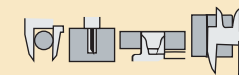

- Super Carbonized Plastic Construction
- Min. Reading: 0.1mm/0.01"
- 1.5V button battery
- Exchange Function Between mm/inch
- Zero-Clearing at Any Position
- Micro Adjustable Wheel, One-Hand Operated
- With RS232 Digital Cable

STANDARD DIGITAL CALIPERS



- Made of Stainless Steel, Matt Finished
- 6mm LCD Screen for Easy Reading
- Super Carbonized Plastic Construction
- Min. Reading: 0.1mm/0.01"
- 1.5V button battery
- Exchange Function Between mm/inch
- Zero-Clearing at Any Position
- Micro Adjustable Wheel, One-Hand Operated
- With RS232 Digital Cable

PART #	LENGTH	6
E0540	100mm	6
E0541	150mm	6
E0542	200mm	6

CARBON FIBER COMPOSITES DIGITAL CALIPER



- Digital Screen for Easy Reading
- Super Carbonized Plastic Construction
- Min. Reading: 0.1mm/0.01"
- 1.5V button battery
- Meet GB/T 14899

PART #	LENGTH	6
E0531	150.0mm	6

STANDARD DIGITAL CALIPERS



- Made of Stainless Steel, Matt Finished
- LCD Screen for Easy Reading
- Measurement for Internal Dia., Outer Dia., Depth or Height
- Exchange Function between mm/inch
- Micro Adjustable Wheel, One-Hand Operated

PART #	LENGTH	6
E0552	150.0mm	6

MICROMETERS



- Precise Measurement for Outer Diameter
Min. Reading: 0.01mm
- Super Casting and Painted Frame, Stainless Steel Body
- Clear and Sharp and Endurable Reading (Matt Chrome Plated)
- Kentanium Tip for Long Life Usage
- Meet and exceed DIN863-2

PART #	LENGTH	
E0561	0-25mm	6
E0562	25-50mm	6
E0563	50-75mm	4

MAGNETIC WORK TORCH



- Apply for finish machining and machine tool etc.
- Magnetic Pull:60kg
- Special and Safer Design Prevent from scalded

PART #	MAGNETIC PULL	LONG SIZE	ΔTΔ	
E0599	60KG	320mm	0.5KG	1

DIAL GAUGE



- Apply for finish machining, machine tool, axial run out and tolerance etc.
- Meet DIN Standard, 58mm Diameter Dial, Min. Reading:0.01mm
- Gear and Rack made of high grade alloy steel, Measure pole made of high grade stainless steel
- Aluminum Alloy Housing, Light Weight and Portable

PART #	MEASURING RANGE	READING	
E0581	0-3mm	0-100	6
E0582	0-5mm	0-100	6
E0583	0-10mm	0-100	6

STANDARD VERNIER CALIPERS



- Measurement for Internal Dia., Outer Dia., Depth or Height
- Made of Stainless Steel
- Matt Finished, Chrome Plated
- Clear and Sharp and Endurable Reading

PART #	LENGTH	
E0511	150mm	6
E0512	200mm	6
E0513	300mm	4

DIGITAL MICROMETERS



- Precise Measurement for Outer Diameter
- Super Casting and Painted Frame, Stainless Steel Body
- Clear and Sharp and Endurable Reading (Matt Chrome Plated)
- Kentanium Tip for Long Life Usage
- LCD Screen with Big and Easy Reading Data With RS232 Digital Cable

PART #	LENGTH	
E0571	0-25mm	6
E0572	25-50mm	6

STANDARD VERNIER CALIPERS



- Special Big Size
- Measurement for Internal Dia., Outer Dia., Depth or Height
- Made of Carbon Steel
- Matt Finished, Chrome Plated, Clear Reading

PART #	LENGTH	
T0514	500mm	1
T0515	600mm	1
T0516	1000mm	1
T0517	1500mm	1
T0518	2000mm	1

DIAL CALIPERS



- Measurement for Internal Dia., Outer Dia., Depth or Height
- Made of Stainless Steel
- Matt Finished, Chrome Plated
- Clear and Sharp and Endurable Reading
- Meet DIN826
- Min. Reading: 0.02mm
- Micro Adjustable Wheel, One-Hand Operated
- Shockproof Indicator Dial

PART #	LENGTH	
E0521	150mm	6
E0522	200mm	6

DIAL GAUGE



- Apply for finish machining, machine tool, axial run out and tolerance etc.
- Meet DIN Standard, 55mm Diameter Dial, Min. Reading:0.001mm
- Gear and Rack made of high grade alloy steel, Measure pole made of high grade stainless steel
- Aluminum Alloy Housing, Light Weight and Portable

PART #	MEASURING RANGE	READING	
E0586	0-1mm	0-100mm	6

ENDURA®
A Textron Company

MANG NETIC STAND



- Magnetic Swith, Easy for moving and placement
- Coattail base, for curved and not flat working place



- Strong Framework, Lengthened Arm
- Magetic Switch, Easy for moving and placement
- Coattail base, for curved and not flat working place

MINI MAGNETIC STAND



Suitable for Dial Gauge
Magnetic Pull:17kg
Easy operation and can be locked to any angle
Mini and Portable

PART #	MAGNETIC PULL	ΔTΔ	
E0598	17KG	0.4KG	1

SCRIBERS



Used for steel precision lineation work
Handle made of high quality alloy, needle made of kentanium

PART #	STYLE	LENGHT	
E0517	Pen-style	150mm	12

MAGNETIC STAND



Suitable for Dial Gauge
Magnetic Pull:60kg
Easy operation and can be locked to any angle

PART #	MAGNETIC PULL	ΔTΔ	
E0597	60KG	1.6KG	1

SCRIBERS



Used for steel precision lineation work
Handle made of high quality alloy, needle made of

PART #	STYLE	LENGHT	
E0518	One-end	180mm	12

MAGNETIC STAND



Suitable for Dial Gauge
Magnetic Pull:60kg

PART #	MAGNETIC PULL	ΔTΔ	
E0596	60KG	1.8KG	6

SCRIBERS



Used for steel precision lineation work
Handle made of high quality alloy, needle made of kentanium

PART #	STYLE	LENGHT	
E0519	Two-end	250mm	12

SPRING DIVIDERS



- Used for steel precision circle lineation, measure, bisectrix work and so on.
- Feet is connected by spring, with adjustable screw nut, convenient to use.

PART #	LENGTH	
E0526	150mm	12
E0527	200mm	12
E0528	250mm	12
E0529	300mm	12

MAGNETIC V-BLOCK

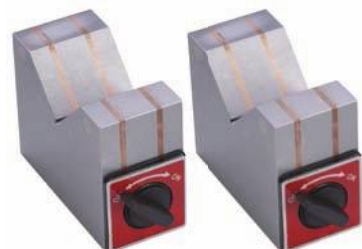

- Mainly used for inspection of cylindrical work pieces, kentanum and correction
- Right angle. Surface is polished.
- Maximum erroneous precision: 0.02mm
- Sales for paired

PART #	CONTENTS	LxWxH	
E0593	15KG	70x40x50mm	1
E0594	20KG	100x50x80mm	1

20PC FEELER GAUGE SET



- Made of 65Mn, polished.
- Male imperial contrast.
- Feeler 3.5" , include 6 pieces of copper,2 wrench, 2 pieces of steel wire.
- Feeler size: 0.05mm,0.10mm,0.15mm,0.20mm,0.25mm,0.30mm,0.35mm,0.40mm,0.45mm,0.50mm,0.55mm,0.60mm,0.65mm,0.70mm,0.75mm,0.80mm,0.85mm,0.90mm,0.95mm,1.00mm
- Meet and exceed DIN2275 and JIS B 7524-1992.

PART #	CONTENTS	
E9732	20PCS	12

SCREW PITCH GAUGES



- Used for measuring the internal & external threads and teeth type Angle

PART #	LEAVES	RANGE	
E0537	24PCS	0.25-6.0mm	12
E0538	28PCS	4-62TPI	12
E0539	52PCS	4-62TPI/0.25-6mm	12

FEELER GAUGE SET



- Total Length:150mm, apply to narrow space.
- Made of 65Mn, polished.
- Male imperial contrast.
- Meet and exceed DIN2275 and JIS B 7524-1992.

PART #	SIZE	CONTENTS	
E9728	0.05-1.0mm	20PCS	12
E9729	0.02-0.50mm	17PCS	12
E9730	0.02-1.0mm	32PCS	12

32PC FEELER GAUGE SET



- Made of 65Mn, polished.
- Male imperial contrast.
- Feeler 3.5" , include 6 pieces of copper,2 wrench, 2 pieces of steel wire.
- Feeler size: 0.02mm,0.03mm,0.04mm,0.05mm,0.06mm,0.07mm,0.08mm,0.09mm,0.10mm,0.13mm,0.15mm,0.18mm,0.20mm,0.23mm,0.25mm,0.28mm,0.30mm,0.33mm,0.38mm,0.40mm,0.45mm,0.50mm,0.55mm,0.60mm,0.63mm,0.65mm,0.70mm,0.75mm,0.80mm,0.85mm,0.90mm,1.00mm
- Meet and exceed DIN2275 and JIS B 7524-1992.

PART #	CONTENTS	
E9733	32PCS	12

RADIUS GAUGES



- Used for measuring the circular arc radius of work piece and convex surface

PART #	LEAVES	RANGE	
E0534	15PCS	15.5-25mm	12
E0535	16PCS	7.5-15mm	12
E0536	17PCS	1.0-7.0mm	12

9PC FEELER GAUGE SET



- Feeler size: 0.04mm,0.05mm,0.06mm,0.07mm,0.08mm, 0.10mm,0.15mm,0.20mm,0.30mm

PART #	CONTENTS	
E9731	9PCS	12

23PC FEELER GAUGE SET



- Made of 65Mn, polished.
- Male imperial contrast.
- Feeler 3.5" , include 6 pieces of copper,2 wrench, 2 pieces of steel wire.
- Feeler size: 0.02mm,0.03mm,0.04mm,0.05mm,0.10mm,0.15mm,0.20mm,0.25mm,0.30mm,0.35mm,0.40mm,0.45mm,0.50mm,0.55mm,0.60mm,0.65mm,0.70mm,0.75mm,0.80mm,0.85mm,0.90mm,0.95mm,1.00mm
- Meet and exceed DIN2275 and JIS B 7524-1992.

PART #	CONTENTS	
E9734	23PCS	12

HSS GROUND THREAD TAP



- Made of premium grade HSS
- Meet DIN 352
- Precise Thread Size



- Made of premium grade HSS
- Meet DIN 223
- Precise Thread Size

14

DRILLING TOOLS

21PC. THREAD TAPS SET



- 4-Tape M3x0.5, M4x0.7, M5x0.8, M6x1
- 3-Tape M8x1.25, M10x1.5, M12x1.75
- 4-Intermediate M3x0.5, M4x0.7, M5x0.8, M6x1
- 3-Intermediate M8x1.25, M10x1.5, M12x1.75
- 4-Plug M3x0.5, M4x0.7, M5x0.8, M6x1
- 3-Plug M8x1.25, M10x1.5, M12x1.75

- Made of premium grade HSS
- Meet and exceed DIN

PART #	CONTENTS	ΔTΔ	
E0201	21PCS	0.64kg	6

28PC. THREAD TAPS DRILLS SET



- 3- Tape, second tape, plug M3
- 3- Tape, second tape, plug M4
- 3- Tape, second tape, plug M5
- 3- Tape, second tape, plug M6
- 3- Tape, second tape, plug M8
- 3- Tape, second tape, plug M10
- 3- Tape, second tape, plug M12
- 3-Hss drill:2.5, 3.2, 4.2mm
- 4-Hss drill:5.0, 6.8, 8.5, 10.2mm
- Made of premium high speed steel.
- Drill Tip with Double Rear Angles, for Good Centering
- Meet and exceed DIN.

PART #	CONTENTS	
E0207	28PCS	6

32PC. THREAD TAPS SET



- 4-Tape M3x0.5, M4x0.7, M5x0.8, M6x1
- 3-Tape M8x1.25, M10x1.5, M12x1.75
- 4-Second Tap M3x0.5, M4x0.7, M5x0.8, M6x1
- 3-Intermediate M8x1.25, M10x1.5, M12x1.75
- 4-Plug M3x0.5, M4x0.7, M5x0.8, M6x1
- 3-Plug M8x1.25, M10x1.5, M12x1.75
- 4-Round M3x0.5, M4x0.7, M5x0.8, M6x1
- 3-Round M8x1.25, M10x1.5, M12x1.75
- 1-Die Holder 1/2"
- 1-Die Holder 1"
- 1-Thread Gauge
- 1-Screwdriver Slotted 3x75mm
- Made of premium grade HSS
- Meet and exceed DIN

PART #	CONTENTS	ΔTΔ	
E0202	32PCS	1.33kg	3

12PC. THREAD TAPS SET



5-M6x1, M7x1, M8x1.25, M10x1.5, M12x1.75
5-M6x1, M7x1, M8x1.25, M10x1.5, M12x1.75
1-Die Holder 1/2" 1-Die Holder 1"

- Made of premium grade HSS.
- Meet and exceed DIN

PART #	CONTENTS	ΔTΔ	📦
E0203	12PCS	0.82kg	1

20PC. THREAD TAPS SET



4-Intermediate M3x0.5, M4x0.7, M9x1.25, M5x0.8
5-Intermediate M6x1, M7x1, M8x1.25, M10x1.5, M12x1.75
4-Round Die M3x0.5, M4x0.7, M9x1.25, M5x0.8
5-Round Die M6x1, M7x1, M8x1.25, M10x1.5, M12x1.75
1-Die Holder 1/2"
1-Die Holder 1"

- Made of premium grade HSS.
- Meet and exceed DIN

PART #	CONTENTS	ΔTΔ	📦
E0204	20PCS	0.93kg	1

40PC. THREAD TAPS SET



4-Tape M3x0.5, M4x0.7, M5x0.8, M6x0.75
4-Tape M7x0.75, M8x1, M10x1.25, M12x1.5
4-Tape M3x0.6, M4x0.75, M5x0.9, M6x1
4-Tape M7x1, M8x1.25, M10x1.5, M12x1.75
4-Round Die M3x0.5, M4x0.7, M5x0.8, M6x0.75
4-Round Die M7x0.75, M8x1, M10x1.25, M12x1.25
4-Round M3x0.6, M4x0.75, M5x0.9, M6x1
4-Round M7x1, M8x1.25, M10x1.5, M12x1.75
1-NPT Tap 1/8-27
1-NPT Die 1/8-27
1-Die Holder 1/2"(M3-M12)
1-T-type Die Holder 1/4"
1-Die Holder 1"(M25)
2-Thread Gauge
1-Slotted Screwdriver 3x75mm

- Made of premium grade HSS.
- Meet and exceed DIN

PART #	CONTENTS	ΔTΔ	📦
E0205	40PCS	1.32kg	1

HSS GROUND THREAD TAP



- Made of premium grade HSS Precise Thread Size
- Meet DIN 352

PART #	THREAD PITCH	SIZE	CONTENTS	📦
E0211	0.5mm	M3	Tape, Second Tap	12
E0212	0.7 mm	M4	Tape, Second Tap	12
E0213	0.8 mm	M5	Tape, Second Tap	12
E0214	1.0 mm	M6	Tape, Second Tap	12
E0215	1.0 mm	M7	Tape, Second Tap	12
E0216	1.25 mm	M8	Tape, Second Tap	12
E0217	1.5 mm	M10	Tape, Second Tap	12
E0218	1.75 mm	M12	Tape, Second Tap	12

NPT HSS GROUND THREAD TAP



- Made of premium grade HSS Precise Thread Size
- Meet ANSI B94.9

PART #	SIZE	📦
E0231	1/8"-27	12

TAP WRENCH



- Work with Thread Tap
- Clamp Made of High Grade Carbon Steel
- Handle Made of Endurable Steel

PART #	SIZE	📦
E0233	1/2"	12

HSS THREAD TAPS SET

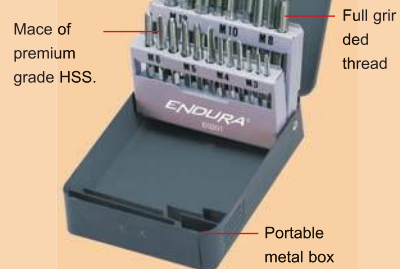
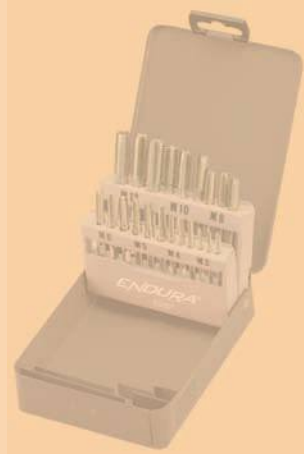

- Durable screw thread.
- Used for equipment repair, maintenance and installment.
- Meet and exceed DIN and ANSI.

HSS GROUND THREAD TAP



- Made of premium grade HSS Precise Thread Size
- Meet DIN 223

PART #	SIZE	THREAD PITCH	📦
E0221	M3	0.5mm	12
E0222	M4	0.7mm	12
E0223	M5	0.8mm	12
E0224	M6	1.0mm	12
E0225	M7	1.0mm	12
E0226	M8	1.25mm	12
E0227	M10	1.5mm	12
E0228	M12	1.75mm	12

NPT HSS GROUND THREAD



- Made of premium grade HSS Precise Thread Size

PART #	SIZE	📦
E0232	1/8"-27	12

T TYPE TAP WRENCH



- Work with Thread Tap
- T type design. Able to Operate by One-hand

PART #	SIZE	📦
E0234	1/4"	12

DIE STOCKS



- Made of zinc alloy. Durable.

PART #	SIZE	📦
E0235	1"	12

ENGINEERING DRILLS



- Drill Bit with 5% Co for Long-Life Usage
- Clear Size Marking for Easy-to-find Drill Tip with Double Rear Angles, for Good Centering

PART #	SIZE	LENGTH	📦
E0411	1.0	34.0mm	10
E0412	1.5	40.0mm	10
E0413	2.0	49.0mm	10
E0415	2.5	53.0mm	10
E0416	2.8	57.0mm	10
E0417	3.0	61.0mm	10
E0418	3.2	61.0mm	10
E0419	3.5	65.0mm	10
E0421	4.0	70.0mm	10
E0422	4.2	75.0mm	10
E0423	4.5	75.0mm	10
E0424	4.8	80.0mm	10
E0425	5.0	86.0mm	10
E0426	5.2	86.0mm	10
E0427	5.5	86.0mm	10
E0429	6.0	93.0mm	10
E0431	6.5	93.0mm	10
E0432	6.8	101.0mm	10
E0433	7.0	109.0mm	10
E0434	7.5	109.0mm	10
E0435	8.0	109.0mm	10
E0436	8.5	117.0mm	10
E0437	9.0	117.0mm	10
E0438	9.5	125.0mm	10
E0439	10.0	125.0mm	10
E0440	10.2	133.0mm	10
E0441	10.5	133.0mm	5
E0442	11.0	133.0mm	5
E0443	11.5	142.0mm	5
E0444	12.0	151.0mm	5
E0445	12.5	151.0mm	5
E0446	13.0	151.0mm	5

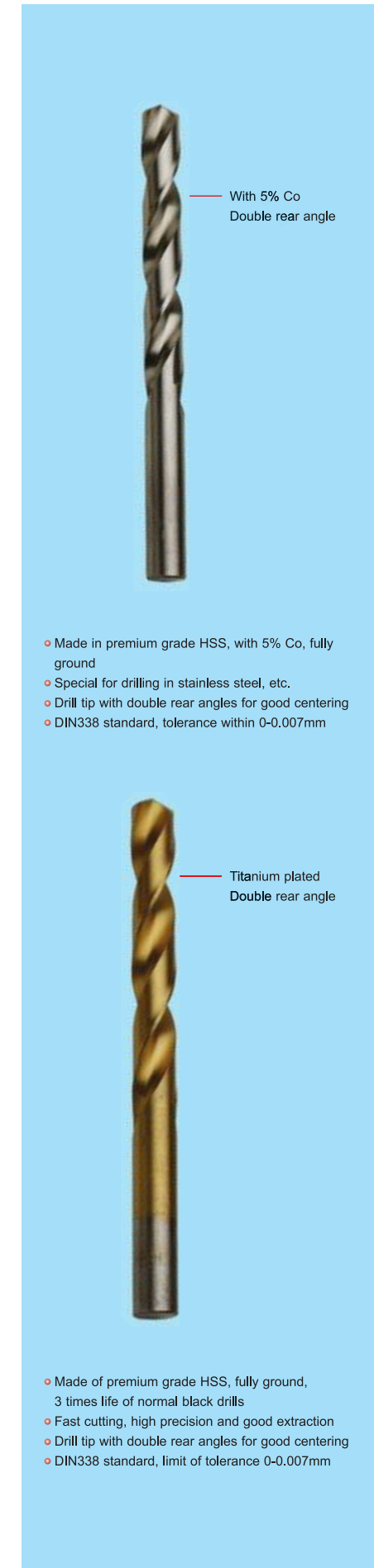

10PC. ENGINEERING DRILLS SET



- Made of premium grade HSS
- Clear Size Marking for Easy-to-find
- Drill Tip with Double Rear Angles, for Good Centering
- 10 - 1.0,2.0,3.0,4.0,5.0,6.0,7.0,8.0,9.0,10.0mm

PART #	CONTENTS	Weight
E0406	10PCS	12

13PC. ENGINEERING DRILLS SET



- Clear Size Marking for Easy-to-find
- Drill Bit with 5% Co for Long-Life Usage
- Drill Tip with Double Rear Angles, for Good Centering
- 13 - 1.5,2.0,2.5,3.0,3.2,3.5,4.0,4.5,4.8,5.0,5.5,6.0,6.5mm

PART #	CONTENTS	Weight
E0401	13PCS	6

25PC. ENGINEERING DRILLS SET



- Clear Size Marking for Easy-to-find
- Drill Bit with 5% Co for Long-Life Usage
- Drill Tip with Double Rear Angles, for Good Centering
- 25-.0,1.5,2.0,2.5,3.0,3.5,4.0,4.5,5.0,5.5,6.0,6.5,7.0,7.5,8.0,
- 8.5,9.0,9.5,10,10.5,11.0,11.5,12.0,12.5,13.0mm

PART #	CONTENTS	Weight
E0403	25PCS	6

6PC..ENGINEERING DRILLS SET



- Made of premium grade HSS
- Clear Size Marking for Easy-to-find
- Drill Tip with Double Rear Angles, for Good Centering
- Titanium coated
- 6 - 2.0,3.0,4.0,5.0,6.0,8.0mm

PART #	CONTENTS	Weight
E0304	6PCS	12

BROKEN SCREW EXTRACTOR



- Apply for taking out broken bolt and screw
- Made of high quality alloy with heat treatment

PART #	SIZE	Weight
E0208	5PCS(1#,2#,3#,4#,5#mm)	6

21PC. THREAD TAPS SET



- 4-Second Tape M3x0.5,M4x0.7,M5x0.8,M9x1.25
- 5-Second Tape M6x1,M7x1,M8x1.25,M10x1.5,M12x1.75
- 4-Round Die M3x0.5,M4x0.7,M5x0.8,M9x1.25
- 5-Round Die M6x1,M7x1,M8x1.25,M10x1.5,M12x1.75
- 1-Die Holder 1/2"
- 1-Die Holder 1"
- 1-24pcs Gauges 0.25-6.0mm
- Size: 380x140x52mm
- Made of premium grade HSS
- Meet and exceed DIN

PART #	CONTENTS	Weight
E0209	21PCS	1.25kg

6PC.ENGINEERING DRILLS SET



- Drill Bit with 5% Co for Long-Life Usage
- Clear Size Marking for Easy-to-find
- 6 - 2.0,3.0,4.0,5.0,6.0,7.0,8.0mm

PART #	CONTENTS	Weight
E0404	6PCS	12

8PC. ENGINEERING DRILLS SET



- Drill Bit with 5% Co for Long-Life Usage
- Clear Size Marking for Easy-to-find
- Drill Tip with Double Rear Angles, for Good Centering
- 8 - 3.0,4.0,5.0,6.0,7.0,8.0,9.0,10.0mm

PART #	CONTENTS	Weight
E0405	8PCS	12

19PC. ENGINEERING DRILLS SET



- Clear Size Marking for Easy-to-find
- Drill Bit with 5% Co for Long-Life Usage
- Drill Tip with Double Rear Angles, for Good Centering
- 19 - 1.0,1.5,2.0,2.5,3.0,3.5,4.0,4.5,5.0,5.5,6.0,6.5,7.0,
- 7.5,8.0,8.5,9.0,9.5,10mm

PART #	CONTENTS	Weight
E0402	19PCS	6



ENGINEERING DRILLS SET



- Made of premium grade HSS
- Clear Size Marking for Easy-to-find
- Drill Tip with Double Rear Angles, for Good Centering
- Titanium coated

PART #	SIZE	LENGTH	Weight
E0311	1.0mm	34.0mm	10
E0312	1.5mm	40.0mm	10
E0347	1.6mm	43.0mm	10
E0348	1.7mm	43.0mm	10
E0349	1.8mm	46.0mm	10
E0313	2.0mm	49.0mm	10
E0350	2.1mm	49.0mm	10
E0314	2.2mm	53.0mm	10
E0351	2.3mm	53.0mm	10
E0352	2.4mm	57.0mm	10
E0315	2.5mm	57.0mm	10
E0353	2.6mm	57.0mm	10
E0354	2.7mm	61.0mm	10
E0316	2.8mm	61.0mm	10
E0355	2.9mm	61.0mm	10
E0317	3.0mm	61.0mm	10
E0356	3.1mm	65.0mm	10
E0318	3.2mm	65.0mm	10
E0357	3.3mm	65.0mm	10
E0358	3.4mm	70.0mm	10
E0319	3.5mm	70.0mm	10
E0359	3.6mm	70.0mm	10
E0360	3.7mm	70.0mm	10
E0320	3.8mm	75.0mm	10
E0361	3.9mm	75.0mm	10
E0321	4.0mm	75.0mm	10
E0362	4.1mm	75.0mm	10
E0322	4.2mm	75.0mm	10
E0363	4.3mm	80.0mm	10
E0364	4.4mm	80.0mm	10
E0323	4.5mm	80.0mm	10
E0365	4.6mm	80.0mm	10
E0366	4.7mm	80.0mm	10
E0324	4.8mm	86.0mm	10
E0367	4.9mm	86.0mm	10

ENGINEERING DRILLS SET



- Made of premium grade HSS
- Clear Size Marking for Easy-to-find
- Drill Tip with Double Rear Angles, for Good Centering
- Titanium coated

PART #	SIZE	LENGTH	Weight
E0325	5.0mm	86.0mm	10
E0368	5.1mm	86.0mm	10
E0326	5.2mm	86.0mm	10
E0369	5.3mm	86.0mm	10
E0370	5.4mm	93.0mm	10
E0327	5.5mm	93.0mm	10
E0371	5.6mm	93.0mm	10
E0372	5.7mm	93.0mm	10
E0328	5.8mm	93.0mm	10
E0373	5.9mm	93.0mm	10
E0329	6.0mm	93.0mm	10
E0374	6.1mm	101.0mm	10
E0330	6.2mm	101.0mm	10
E0375	6.3mm	101.0mm	10
E0376	6.4mm	101.0mm	10
E0331	6.5mm	101.0mm	10
E0377	6.6mm	101.0mm	10
E0378	6.7mm	101.0mm	10
E0332	6.8mm	109.0mm	10
E0379	6.9mm	109.0mm	10
E0333	7.0mm	109.0mm	10
E0380	7.2mm	109.0mm	10
E0334	7.5mm	109.0mm	10
E0335	8.0mm	117.0mm	10
E0336	8.5mm	117.0mm	10
E0337	9.0mm	125.0mm	10
E0338	9.5mm	125.0mm	10
E0339	10.0mm	133.0mm	10
E0340	10.2mm	133.0mm	5
E0341	10.5mm	133.0mm	5
E0342	11.0mm	142.0mm	5
E0343	11.5mm	142.0mm	5
E0344	12.0mm	151.0mm	5
E0345	12.5mm	151.0mm	5
E0346	13.0mm	151.0mm	5

8PC. ENGINEERING DRILLS SET



- Made of premium grade HSS
Clear Size Marking for Easy-to-find
- Drill Tip with Double Rear Angles, for Good Centering
- Titanium coated
8 - 3.0,4.0,5.0,6.0,8.0,9.0,10.0mm

PART #	CONTENTS	
E0305	8PCS	12

10PC. ENGINEERING DRILLS SET



- Made of premium grade HSS
Clear Size Marking for Easy-to-find
- Drill Tip with Double Rear Angles, for Good Centering
- Titanium coated
10 - 1.0, 2.0, 3.0,4.0,5.0,6.0,8.0,9.0,10.0mm

PART #	CONTENTS	
E0306	10PCS	12

13PC. ENGINEERING DRILLS SET



- Made of premium grade HSS
Clear Size Marking for Easy-to-find
- Drill Tip with Double Rear Angles, for Good Centering
- Titanium coated
13 - 1.5,2.0,2.5,3.0,3.2,3.5,4.0,4.5,4.8,5.0,5.5,6.0,6.5mm

PART #	CONTENTS	
E0301	13PCS	6

19PC. ENGINEERING DRILLS SET



- Made of premium grade HSS
Clear Size Marking for Easy-to-find
- Drill Tip with Double Rear Angles, for Good Centering
- Titanium coated
19 - 1.0,1.5,2.0,2.5,3.0,3.5,4.0,4.5,5.0,5.5,6.0,6.5,7.0,7.5,8.0,8.5,9.0,9.5,10mm

PART #	CONTENTS	
E0302	19PCS	6

25PC. ENGINEERING DRILLS SET



- Made of premium grade HSS
Clear Size Marking for Easy-to-find
Drill Tip with Double Rear Angles, for Good Centering
- Titanium coated
- 19 - 1.0,1.5,2.0,2.5,3.0,3.5,4.0,4.5,5.0,5.5,6.0,6.5,7.0,7.5,8.0,8.5,9.0,9.5,10,10.5,11.0,11.5,12.0,12.5,13.0mm

PART #	CONTENTS	
E0303	25PCS	6



15

ABRASIVE PRODUCTS

Aluminium Abrasive Cloth



PART #	SIZE	LxW	
T0212	P36	230x280mm	50
T0213	P40	230x280mm	50
T0214	P60	230x280mm	50
T0215	P80	230x280mm	50
T0216	P100	230x280mm	50
T0217	P120	230x280mm	50
T0218	P150	230x280mm	50
T0219	P180	230x280mm	50

ENDURA®
A Textron Company

ENDURA®
A Textron Company

ENDURA®
A Textron Company

16

WELDING TOOLS



WELDING GLOVE



- Made of cowhide, durable and wearable.

PART #	WxH	
E0831	14"	12

WELDING MIRROR



- Resist from arc harm, resist from ultraviolet and infrared ray
- Quick Light Alternating

PART #	SIZE	
E0851	Transparent	12
E0852	Darken: (9# optic)	12

WELDING GLOVE



- Made of cowhide, full cotton insert, comfortable

PART #	WxH	
E0835	14"	6

REGULATOR



- Made of high-grade brass.
- Durable.
- Intake pipe with special filtering device

PART #	SIZE	
E0871	YQY	1

ELECTRODE HOLDER



- Clamp Tip Made of Copper, Good Electric Conduction
- Handle Made of High Grade Plastic, in Good Insulation of High Temperature, Pulse and Fire

PART #	SIZE	COPPER CONDUCTOR	
E0811	300A	170g	12
E0812	500A	250g	12
E0813	300-800A	320g	12

WELDING MASK



- Made of PP, shock-proof, light weight
- Resist from fire, high temperature, welding slag, ultraviolet and infrared rays

PART #		
E0841		6

ELECTRODE HOLDER



- Clamp Tip Made of Copper, Good Electric Conduction
- Handle Made of High Grade Plastic, in Good Insulation of High Temperature, Pulse and Fire

PART #	SIZE	COPPER CONDUCTOR	
E0821	300A	260g	12
E0822	500A	400g	12

WELDING MASK



- Made of PP, shock-proof, light weight
- Resist from fire, high temperature, welding slag, ultraviolet and infrared rays
- Head Type for hands-free

PART #		
E0845		6

REGULATOR



- Made of high-grade brass.
- Durable.
- Intake pipe with special filtering device

PART #	SIZE	
E0872	YQE	1

REGULATOR



- Made of high-grade brass.
- Durable.
- Intake pipe with special filtering device

PART #	SIZE	
E0873	YQW	1

WELDING TORCH

stainless steel air pipe, more sturdy and durable, and it can avoid bending used by knocking.

made of high-grade brass.

All aluminum alloy handle, feel more conformtable.

- stainless steel air pipe, more sturdy and durable.
- have equipped with 2 # propane cutting nozzle.

CUTTING TORCH



- Made of high-grade brass.
- Handle made of Aluminum ally.
- Airway made of stainless, enduring.
- Equipped with 2# cutting tip.

PART #	SIZE	
E0862	30 Type	1
E0863	100 Type	1
E0864	300 Type	1

CUTTING TIP



- Made of high-grade copper.
- Polished.

PART #	SIZE	
T0611	30 type 1#	12
T0612	30 type 2#	12
T0613	30 type 3#	12
T0614	100 type 1#	12
T0615	100 type 2#	12
T0616	100 type 3#	12
T0617	300 type 1#	12
T0618	300 type 2#	12
T0619	300 type 3#	12

CUTTING TIP



- Core department made of brass, produced by Computerized Numerical Control machine.

PART #	SIZE	
T0631	30 type 1#	12
T0632	30 type 2#	12
T0633	30 type 3#	12
T0634	100 type 1#	12
T0635	100 type 2#	12
T0636	100 type 3#	12
T0637	300 type 1#	12
T0638	300 type 2#	12
T0639	300 type 3#	12

CUTTING TIP



- Core department made of brass, produced by Computerized

PART #	SIZE	
T0651	6 type 1#	12
T0652	6 type 2#	12
T0653	6 type 3#	12
T0654	6 type 4#	12
T0655	6 type 5#	12
T0656	6 type 6#	12
T0657	12 type 1#	12
T0658	12 type 2#	12
T0659	12 type 3#	12
T0660	12 type 4#	12
T0661	12 type 5#	12
T0662	12 type 6#	12

WELDING TORCH

stainless steel air pipe, more sturdy and durable, and it can avoid bending used by knocking.

made of high-grade brass.

All aluminum alloy handle, feel more conformtable.

- stainless steel air pipe, more sturdy and durable.
- have equipped with 2 # acetylene cutting nozzle.



- Made of high-grade brass.
- Handle made of Aluminum alloy ally.
- Airway made of stainless, enduring.
- Equipped with 2# cutting tip.

PART #	SIZE	
E0866	6 Type	1
E0867	12 Type	1



17

CONSTRUCTION TOOLS

TAPE MEASURE



- Blade made of carbon steel, spraying paint on surface.
- Comfortable gripped soft ABS case.
- Zero setting.

PART #	SIZE	LENGTH	📦
E8001	2mx13mm	2m	12
E8002	3mx16mm	3m	12
E8004	5mx19mm	5m	12

TAPE MEASURE



- Blade made of carbon steel; spraying paint on surface.
- Two tone rubber&plastic case, comfortable to use and resistant to impact.
- Zero setting. Light blade easily pulled out.

PART #	SIZE	LENGTH	📦
E8032	3mx16mm	3m	12
E8034	5.5mx19mm	5.5m	12
E8036	8mx25mm	8m	12

TAPE MEASURE



- Blade made of 50#C; spraying paint on surface.
- Two tone rubber&plastic case; resistant to impact; zero setting.

PART #	SIZE	LENGTH	📦
E8012	3mx16mm	3m	12
E8014	5mx19mm	5m	12
E8016	7.5mx25mm	7.5m	12
E8017	10mx25mm	10m	12

TAPE MEASURE



- Blade made of high-grade steel. High precision printing and wear resistance.
- Zero setting ensure precision.
- Coat made of ABS, impact resistance.

PART #	SIZE	LENGTH	📦
E8041	10m	6	6
E8042	20m	6	6
E8043	30m	6	6
E8044	50m	6	6

TAPE MEASURE



- Meet and exceed JIS; spraying paint on surface.
- Comfortable gripped soft ABC case.
- Zero setting.

PART #	SIZE	LENGTH	📦
E8022	3mx16mm	3m	12
E8024	5mx19mm	5.5m	12
E8026	7.5mx25mm	7.5m	12

TAPE MEASURE



- Blade made of high-grade glass fiber. Bear 50kg tension. Printed in metric imperial contrast.
- Zero setting ensure precision.
- Coat made of ABS, impact resistance.
- Handle made of TPR, impact resistance.
- Pointed design of the bottom, comfortable to use.

PART #	SIZE	LENGTH	📦
E8048	50m	6	6

ALUMINUM ALLOY ANGLE SQUARE



- Stainless steel

PART #	SIZE	📦
E8073	250mm	12
E8074	300mm	12

STEEL RULES



- Stainless steel

PART #	SIZE	LENGTH	📦
E8062	150mmx18mm	150mm	10
E8064	300mmx25mm	300mm	10
E8065	500mmx25mm	500mm	10
E8066	1000mmx30mm	1000mm	10

LEVEL



- Made of aluminum alloy, Accuracy: 0.75mm/m
- Reinforced magnetism construction

PART #	SIZE	LENGTH	📦
E8082	450mm	450mm	6
E8083	600mm	600mm	6
E8084	800mm	800mm	6
E8085	1000mm	1000mm	6
E8086	1200mm	1200mm	6

HAND RIVETER



- Apply for joint and fasten metal, fiber, leather and plastic with four nozzles.
- Spring handle enable rivet easily.
- Steel body with high-grade alloy steel nozzle.
- Long nose design, ideal for usage in recessed areas.

PART #	SIZE	📦
E7921	10"	6

HAND RIVETER



- Apply for joint and fasten metal, fiber, leather and plastic with four nozzles.
- Steel body with high-grade alloy steel nozzle.
- Nozzles made of high-tech alloy steel, suitable for stainless steel rivet.
- With professional loading wrench inside handle.

PART #	SIZE	📦
E7922	10"	6

CARTRIDGE GUN



- Mainly apply for gluing of metal, fiber, leather, plastic and glass
- 360 angle swivel body, ideal for usage in corner and gap.
- Body made of high quality steel, handle made of zinc alloy.

PART #	SIZE	📦
E7911	9"	6

CARTRIDGE GUN



- Mainly apply for gluing of metal, fiber, leather, plastic and glass
- 360 angle swivel body, ideal for usage in corner and gap.
- Body made of high quality steel, handle made of zinc alloy.
- High quality spanner made of powder casting allow to extrude hi-viscosity glue.

PART #	SIZE	📦
E7912	9"	6

BRUSH



- Made of bristle.

PART #	SIZE	BRISTLE LENGTH	📦
E9703	1.5"	38.0mm	12
E9704	2"	45.0mm	12
E9705	2.5"	45.0mm	12
E9708	4"	45.0mm	12

SCRAPER



- Made of stainless steel.

PART #	SIZE	BLADE WIDTH	📦
E9773	2"	50.0mm	12
E9774	2.5"	63.0mm	12
E9775	3"	75.0mm	12
E9777	4"	100.0mm	12

BRICKLAYING TROWEL



- Made of superior Mn alloy.

PART #	SIZE	📦
E9783	6"	6
E9784	7"	6

SUCTION GRIPPER SINGLE HEAD



- Rubber suction cup, diameter 120mm
- Workable on clean glass, metal, wood and others
- Horizontal absorption force up to 40kg
- Do not suck glass<3mm(thickness)

PART #	📦
E9792	1

SUCTION GRIPPER DOUBLE HEADS



- Rubber suction cup, diameter 120mm
- Workable on clean glass, metal, wood and others
- Horizontal absorption force up to 40kg
- Do not suck glass<3mm(thickness)

PART #	📦
E9791	1

18

CUTTING TOOLS



KNIFE



- Plastic handle.
- Equipped with blade: E7009.
- Blade size: 18x 100mm, thickness: 0.5mm

PART #	CONTENTS	SIZE	THICKNESS	
E7003	1 Blade	8Joint 18x100mm	0.5mm	12

MINI UTILITY KNIFE



- Plastic handle.
- Equipped with blade: E7011.
- Blade size: 9x28.5mm, thickness:0.5mm

PART #	CONTENTS	SIZE	THICKNESS	
E7007	1 Blade	9x28.5mm	0.4mm	12

KNIFE



- Plastic handle
- Equipped with blade: E7008.
- Blade size: 9x80mm, thickness:0.4mm

PART #	CONTENTS	SIZE	THICKNESS	
E7001	1 Blade	13 Joint 9x80mm	0.4mm	12

KNIFE



- Rubber handle
- Equipped with blade: E7009.
- Blade size: 18x 100mm, thickness: 0.5mm

PART #	CONTENTS	SIZE	THICKNESS	
E7004	1 Blade	8Joint18x100mm	0.5mm	12

KNIFE BLADE



- Premium-grade sharp blade.

PART #	CONTENTS	SIZE	THICKNESS	
E7008	12 Blade	13 Joint 9x80mm	0.4mm	12
E7009	12 Blade	8 Joint 18x100mm	0.5mm	12
E7010	12 Blade	18x62mm	0.5mm	12
E7011	12 Blade	9x28.5mm	0.4mm	12
E7012	10 Blade	13 Joint 9x80mm	0.4mm	12
E7013	10 Blade	8 Joint 18x100mm	0.5mm	12

KNIFE



- Equipped with blade: E7008.
- Blade size: 9x80mm, thickness:0.4mm
- Handle made of Zinc alloy.

PART #	CONTENTS	SIZE	THICKNESS	
E7002	1 Blade	13Joint9x80mm	0.4mm	12

KNIFE



- Equipped with blade: E7009.
- Blade size: 18x100mm, thickness:0.5mm
- Handle made of Zinc alloy.

PART #	CONTENTS	SIZE	THICKNESS	
E7014	1 Blade	18mm	0.5mm	12

LIGHTWEIGHT UTILITY KNIFE



- Plastic handle
- Equipped with blade: E7010.
- Blade size: 18x62mm, thickness:0.5mm

PART #	CONTENTS	SIZE	THICKNESS	
E7005	1 Blade	18x62mm	0.5mm	12

KNIFE



- Plastic handle.
- Equipped with blade: E7009.
- Blade size: 18x 100mm, thickness: 0.5mm

PART #	CONTENTS	SIZE	THICKNESS	
E7017	6 Blade	8Joint18x100mm	0.5mm	12

UTILITY KNIFE



- Aluminum-alloy handle.
- Equipped with blade: E7010.

PART #	CONTENTS	SIZE	THICKNESS	
E7006	1 Blade	18x62mm	0.5mm	12

UTILITY KNIFE



- Aluminum-alloy handle.
- Equipped with blade: E7010.
- Blade size: 18x62mm, thickness:0.5mm

PART #	CONTENTS	SIZE	THICKNESS	
E7015	1 Blade	18x62mm	0.5mm	12

STAINLESS STEEL



- Suitable for trimming thrum, durable and convenient to use.
- Stainless blade.

PART #	SIZE	LENGTH	#
E7044	4"		6

MINI HACKSAW



- Good-looking paint-spraying saw.
- Comfortable-to-hold nylon handle.
- Safe and durable.

PART #	SIZE	LENGTH	#
E7052	6"	260.0mm	6

HACKSAW



- Present: a BL-Metal saw Blades
- Aluminum-alloy handle.
 - Paint spraying. Rubber grip, comfortable to hold.

PART #	SIZE	LENGTH	#
E7053	12"	395.0mm	10

3PC.MINI SAW BLADES



- Imported saw, good elasticity.
- Sharp blade, high tenacity.

PART #	SIZE	LENGTH	#
E9741	6"	152.4mm	12

BI-METAL SAW BLADES



- Teeth made of HHS, the rest of saw made of premium grade steel.
- Good elasticity and high hardness.

PART #	SIZE	LENGTH	#
E7071	18 Teeth	12"	100
E7072	24 Teeth	12"	100
E7073	32 Teeth	12"	100

BI-METAL SAW BLADES



- Teeth made of HSS,
- Blade body made of premium grade spring steel, Good elasticity and hardness

PART #	SIZE	LENGTH	#
E7024	375X25X1.25mm	375mm	10
E7025	375X32X1.6mm	375mm	10

STAINLESS STEEL SCISSOR



- Blade made of premium grade stainless steel.

PART #	SIZE	LENGTH	#
E7141	7"	175mm	12

HACKSAW



- Present: a BL-Metal saw Blades
- Aluminum-alloy handle. Paint spraying.

PART #	SIZE	LENGTH	#
E7054	12"	393.0mm	6

STAINLESS STEEL SCISSOR



- Blade made of premium grade stainless steel.
- Two tone handle, comfortable to hold.

PART #	SIZE	LENGTH	#
E7042	8"	195.0mm	12
E7043	9"	220.0mm	12

HACKSAW



- Present: a BL-Metal saw Blades
- ABS handle.

PART #	SIZE	LENGTH	#
E7055	12"	430.0mm	6

10PC FILE SET



- Excellent for filing small and precise metal parts.
- Consists of flat file, three-square file, square file, half-round file, round file, fine point file.

PART #	SIZE	CONTENTS	ΔTΔ	#
E9031	4x160mm	10PCS	0.1kg	12

6PC FILE SET



- Excellent for filing small and precise metal parts.
- Consists of flat file, three-square file, square file, half-round file, round file, fine point file.

PART #	SIZE	CONTENTS	ΔTΔ	#
E9033	3x140mm	6PCS	0.2kg	12
E9034	4x160mm	6PCS	0.3kg	12
E9035	5x180mm	6PCS	0.4kg	12

FILE



- Made of 45# steel and man-mand diamond. High hardness.
- Excellent for filing very hard materials.

PART #	SIZE	LENGTH	#
E9001	3X140mm	Flat	12
E9002	3X140mm	Nail	12
E9003	3X140mm	Half round	12
E9004	3X140mm	Round	12
E9005	3X140mm	Three-square	12
E9006	3X140mm	Square	12
E9007	4X160mm	Flat	12
E9008	4X160mm	Nail	12
E9009	4X160mm	Half round	12
E9010	4X160mm	Round	12
E9011	4X160mm	Three-square	12
E9012	4X160mm	Square	12
E9013	5X180mm	Flat	12
E9014	5X180mm	Nail	12
E9015	5X180mm	Half round	12
E9016	5X180mm	Round	12
E9017	5X180mm	Three-square	12
E9018	5X180mm	Square	12

DIAMOND FILE



- Made of 45# steel and man-made diamond. High hardness.
- Excellent for filing very hard materials.

PART #	SIZE	LENGTH	#
E9042	3x140mm	10PC	12
E9044	4x160mm	10PC	12
E9046	5x180mm	10PC	12

DIAMOND FILE



- Made of 45# steel and man-made diamond. High hardness.
- Excellent for filing very hard materials.

PART #	SIZE	SHAPE	#
E9051	3x140mm	Flat	12
E9052	3x140mm	Half round	12
E9053	3x140mm	Round	12
E9061	4x160mm	Flat	12
E9062	4x160mm	Half round	12
E9063	4x160mm	Round	12
E9071	5x180mm	Flat	12
E9072	5x180mm	Half round	12
E9073	5x180mm	Round	12

WOOD CHISEL



PART #	SIZE	#
E9401	1/2"	12
E9402	3/4"	12
E9403	1"	12

3PC. WOOD CHISEL SET



- 3- 1/2", 3/4", 1"

PART #	CONTENTS	ΔTΔ	#
E1561	3PCS	0.4kg	6

WOOD CHISEL SET



- 3-1/2", 3/4", 1"

- Made of Cr-V; sharp blade.

PART #	CONTENTS	ΔTΔ	#
E1562	3PCS	0.5	3

FLAT FILE



- Suitable for filing cambered surface, boarder, edge, etc.
- Premium grade steel, heat treated.
- Dual color plastic handle.
- Meet GB/T 5806-2003&DIN 7261.
- Perfect file teeth design for clean and quick job

PART #	SIZE	Teeth	#
E9104	6"	Sharp Teeth	3# 6
E9105	8"	Sharp Teeth	3# 6
E9106	10"	Sharp Teeth	3# 6
E9107	12"	Sharp Teeth	3# 6
E9100	6"	Mid Teeth	2# 6
E9101	8"	Mid Teeth	2# 6
E9102	10"	Mid Teeth	2# 6
E9103	12"	Mid Teeth	2# 6
E9111	8"	Big Teeth	1# 6
E9112	10"	Big Teeth	1# 6
E9113	12"	Big Teeth	1# 6

HALF-ROUND FILE



- Suitable for filing cambered surface, hole or flat surface, etc.
- Premium grade steel, heat treated.
- Dual color plastic handle.
- Meet GB/T 5806-2003&DIN 7261.
- Perfect file teeth design for clean and quick job

PART #	SIZE	Teeth	#
E9126	6"	Sharp Teeth	3# 6
E9127	8"	Sharp Teeth	3# 6
E9128	10"	Sharp Teeth	3# 6
E9129	12"	Sharp Teeth	3# 6
E9120	6"	Mid Teeth	2# 6
E9121	8"	Mid Teeth	2# 6
E9122	10"	Mid Teeth	2# 6
E9123	12"	Mid Teeth	2# 6
E9114	6"	Big Teeth	1# 6
E9115	8"	Big Teeth	1# 6
E9116	10"	Big Teeth	1# 6
E9117	12"	Big Teeth	1# 6

ROUND FILE



- Suitable for filing hole or flat surface, etc.
- Premium grade steel, heat treated.
- Dual color plastic handle.
- Meet GB/T 5806-2003&DIN 7261.
- Perfect file teeth design for clean and quick job.

PART #	SIZE	Teeth	#
E9130	6"	Mid Teeth	2# 6
E9131	8"	Mid Teeth	2# 6
E9132	10"	Mid Teeth	2# 6
E9133	12"	Mid Teeth	2# 6

THREE-SQUARE FILE



- Suitable for filing hole or flat surface, etc.
- Premium grade steel, heat treated.
- Dual color plastic handle.
- Meet GB/T 5806-2003&DIN 7261.
- Perfect file teeth design for clean and quick job

PART #	SIZE	Teeth	#
E9142	6"	Mid Teeth	2# 6
E9143	8"	Mid Teeth	2# 6
E9144	10"	Mid Teeth	2# 6
E9145	12"	Mid Teeth	2# 6

SQUARE FILE



- Suitable for filing hole or flat surface, etc.
- Premium grade steel, heat treated.
- Dual color plastic handle.
- Meet GB/T 5806-2003&DIN 7261.
- Perfect file teeth design for clean and quick job

PART #	SIZE	Teeth	#
E9163	6"	Sharp Teeth	3# 6
E9165	10"	Sharp Teeth	3# 6
E9150	6"	Mid Teeth	2# 6
E9151	8"	Mid Teeth	2# 6
E9152	10"	Mid Teeth	2# 6
E9153	12"	Mid Teeth	2# 6

BOLT CUTTER



- Jaw made of alloy steel.
- 45° angle design.

PART #	SIZE	LENGEH	#
E9451	8"	200mm	6

BOLT CUTTER



- Jaw made of alloy steel.

PART #	SIZE	LENGEH	#
E9450	8"	200mm	6

BOLT CUTTER



- Jaw made of CR-V.

PART #	SIZE	LENGTH	#
E9452	12"	300mm	4
E9453	14"	350mm	4
E9454	18"	450mm	2
E9455	24"	600mm	2
E9456	30"	750mm	1
E9457	36"	900mm	1



PART #	SIZE	LENGEH	#
E9462	12"	E9452	6
E9463	14"	E9453	6
E9464	18"	E9454	6
E9465	24"	E9455	4
E9466	30"	E9456	4
E9467	36"	E9457	2

DEBURRING TOOL



- Used to remove the burr on steel, copper and plastic parts.
- Equipped with blade E7063.

PART #	SIZE	#
E7061	115mm	12

DEBURRING TOOL



- Used to remove the burr on steel, copper and plastic parts.
- Equipped with blade E7063.

PART #	SIZE	#
E7062	125mm	12

DEBURRING BLADES



- Made of high speed steel.
- Suitable for copper and plastic parts.

PART #	SIZE	CONTENTS	#
E7063	48mm	10PCS	12

BOLT CUTTER TIPS



- incorporated with E9452-E9457
- made of HSS
- particularly suitable for high-temperature environment

PART #	SIZE	FOR	#
E9473	14"	E9453	6
E9474	18"	E9454	6
E9475	24"	E9455	6
E9476	30"	E9456	6
E9477	36"	E9457	6



19

PIPE TOOLS

PIPE TOOL

PIPE WRENCH



- Jaw made of drop-forged Cr-V; handle made of drop-forged iron.

PART #	SIZE	LENGTH	
E5651	8"	200.0mm	4
E5652	10"	250.0mm	4
E5653	12"	300.0mm	4
E5654	14"	350.0mm	2
E5655	18"	450.0mm	2
E5656	24"	600.0mm	1
E5657	36"	900.0mm	1
E5658	48"	1200.0mm	1

PIPE WRENCH



- Jaw made of drop-forged Cr-V; handle made of drop-forged iron.
- Meet and exceed QB/T2508-2001.

PART #	SIZE	LENGTH	
E5641	8"	200.0mm	4
E5642	10"	250.0mm	4
E5643	12"	300.0mm	4
E5644	14"	350.0mm	2
E5645	18"	450.0mm	2
E5646	24"	600.0mm	1
E5647	36"	900.0mm	1
E5648	48"	1200.0mm	1

PIPE WRENCH

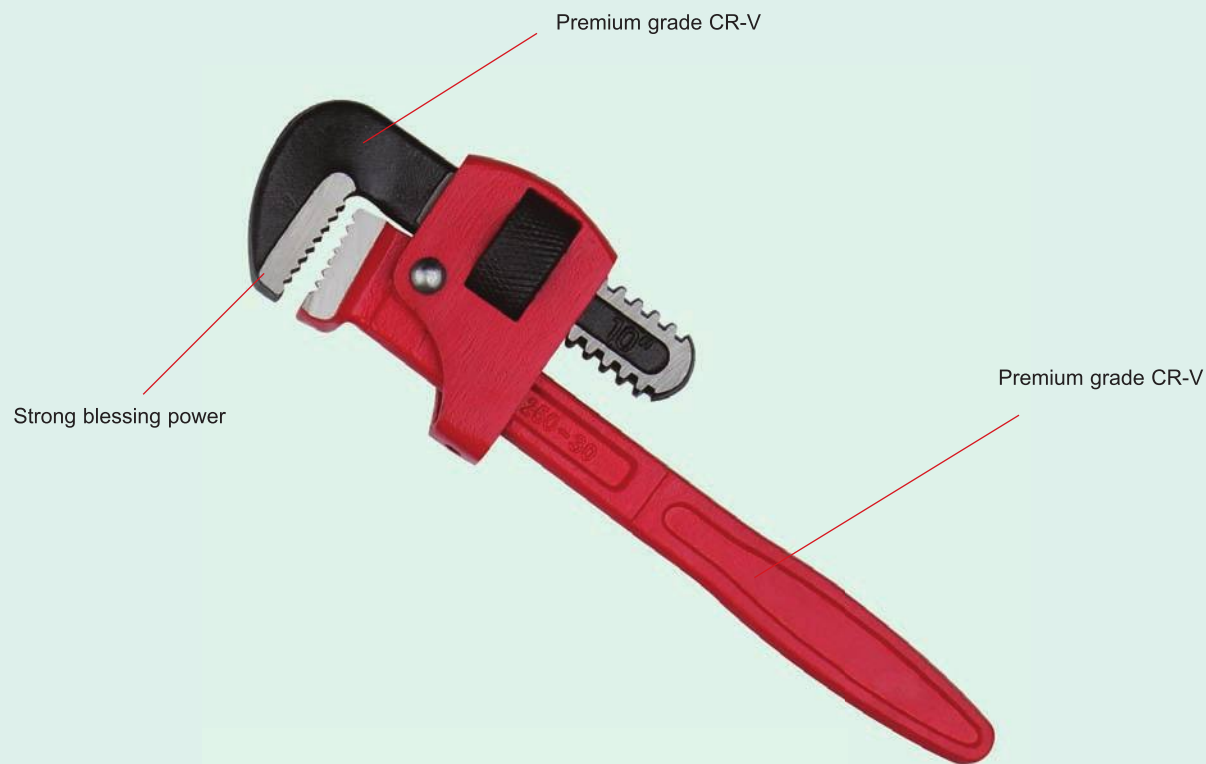

Standard:GGG-W-00651d (GSA-FSS) Type I Class A

PIPE TOOL

ADJUSTABLE PIPE WRENCH



- Jaw and handle are made of drop-forged Cr-V;
- Special long handle.
- Suitable for oil pipeline construction, drilling operation.

PART #	SIZE	LENGTH	
E5696	18"	450.0mm	2
E5697	24"	600.0mm	1
E5698	36"	900.0mm	1
E5699	48"	1200.0mm	1

PIPE WRENCH



- Jaw made of drop-forged Cr-V; handle made of Aluminum alloy..

PART #	SIZE	LENGTH	
E5662	10"	200.0mm	4
E5663	12"	300.0mm	4
E5664	14"	350.0mm	4
E5665	18"	450.0mm	2
E5666	24"	600.0mm	1
E5667	36"	900.0mm	1
E5668	48"	1200.0mm	1

PIPE WRENCH



- Jaw and handle are made of drop-forged Cr-V;
- Special long handle. Teeth on two side.
- Suitable for oil pipeline construction, drilling operation.

PART #	SIZE	LENGTH	
E5639	100-200mm	900-1200mm	1

CHAIN WRENCH



- Made of alloy.

PART #	SIZE	
E5631	12"/28 Joint Chain /55-105mm	12
E5632	15"/34 Joint Chain/60-135mm	12

MINI TUBING CUTTER



- Suitable for cutting the copper tube, aluminum tube, etc. with the diameter between 3mm and 22mm. Made of aluminum alloy.

PART #	SIZE	BLADE	
E7081	3-22mm	4.8x18mm	6

TUBING CUTTER



- Suitable for cutting the copper tube, aluminum tube, etc. with the diameter between 3mm and 32mm. Made of aluminum alloy.

PART #	SIZE	BLADE	
E7082	3-32mm	4.8x18mm	6

TUBING CUTTER



- Suitable for cutting the copper tube, aluminum tube, etc. with the diameter between 6mm and 67mm. Made of aluminum alloy.

PART #	SIZE	BLADE	FOR #
E7084	6-67mm	5x22mm	6

PVC TUBING CUTTER



- Aluminum Alloy Turret, stainless steel blade
- Apply for cutting PVC, PPR pipeline

PART #	SIZE	FOR #
E7091	42mm	6

PVC TUBING CUTTER



- Suitable for cutting PVC, ABS, CPVC tubes with the diameter between 3mm and 42mm.
- Aluminum alloy handle; heat treated; SK5 blade.

PART #	SIZE	FOR #
E7092	3-42mm	6

TUBING CUTTER



- Suitable for cutting the copper tube, aluminum tube, etc. with the diameter between 5mm and 50mm. Made of aluminum alloy.

PART #	SIZE	BLADE	FOR #
E7083	5-50mm	4.8-18mm	6

PVC TUBING CUTTER



- Aluminum Alloy Turret, 65Mn blade
- Apply for cutting PVC, PPR pipeline

PART #	SIZE	FOR #
E7093	42mm	6

PVC TUBING CUTTER



- Aluminum Alloy Turret, 65Mn blade
- Apply for cutting PVC, PPR pipeline

PART #	SIZE	FOR #
E7094	63mm	6

MULTIBENDER

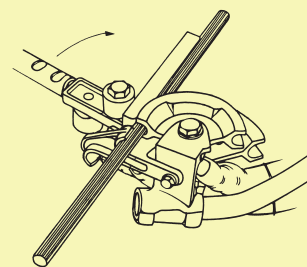

Open the bender and put tubes in it

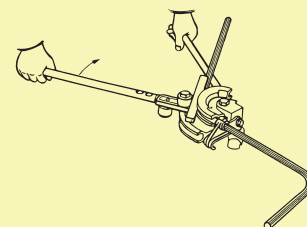

Press to bend the required style

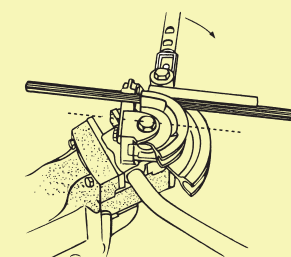

Bender can be fixed in vise

BLADE CUTTER



E7088



E7089

- Made of SK5

PART #	FOR #	FOR #
E7088	E7092	12
E7089	E7091	6

BLADE CUTTER



E7090



E7095

- Made of 65Mn

PART #	FOR #	FOR #
E7090	E7094	12
E7095	E7093	12

2PC. SPARE BLADE

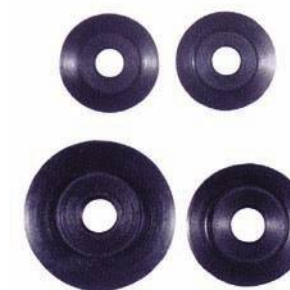

- Suitable for cutting the copper tube, aluminum tube, etc. with the diameter between 5mm and 67mm.
- Made of aluminum alloy.

PART #	SIZE	FOR #
E7086	4.8x18x3mm	E7081/E7082
E7087	5x18x6mm	E7083
E7096	5x22x6mm	E7084

BENDER



- For bending annealed brass and aluminum tubes, 20# steel and seamless brass tube etc.
- Bending wheel made by one-step technic with smooth surface.

PART #	SIZE	FOR #
E5672	6mm/8mm	1
E5673	10mm	1
E5674	12mm	1

MULTI BENDER



- For bending annealed brass and aluminum tubes, 20# steel and seamless brass tube etc.
- Bending wheel made by one-step technic with smooth surface.
- Optional function, Bends brass or aluminum tube from 16mm to 22mm and 19mm to 25mm easily.

PART #	SIZE	FOR #
E5681	16-22mm	1
E5682	19-25mm	1

3-IN-1 BENDER



- For bending annealed brass and aluminum tubes, 20# steel and seamless brass tube etc.
- Bending wheel made by one-step technic with smooth surface.
- Optional function, allow to bend 1/4", 5/16" & 3/8" brass tube and aluminum tube.

PART #	SIZE	SIZE	FOR #
E5686	0-90°	1/4"-3/8"	12
E5687	0-180°	1/4"-3/8"	12

20

SAFETY TOOLS



PIPE WRENCHES



- Made of special Be-Br, safe and durable

PART #	SIZE	LENGHT	⊞
E8932	10"	250.0mm	6
E8934	14"	350.0mm	6
E8935	18"	450.0mm	6

ADJUSTABLE WRENCH



- Made of Special Be-Br, safe
- Heavy duty design, thickened handle, durable

PART #	SIZE	LENGHT	⊞
E8912	8"	200.0mm	6
E8913	10"	250.0mm	6
E8914	12"	300.0mm	6

BALL PEIN HAMMER



- Made of special Be-Br, safe
- TPR handle, comfortable

PART #	SIZE	LENGHT	⊞
E8962	16 oz	315.0mm	6
E8963	24 oz	340.0mm	6

SCREWDRIVER PHILLIPS



- Blade made of special Be-Br, safe
- Two tone TPR handle, comfortable

PART #	SIZE	LENGHT	⊞
E8952	6×100mm	190.0mm	6
E8953	6×150mm	240.0mm	6
E8954	8×200mm	290.0mm	6
E8955	8×250mm	340.0mm	6

SCREWDRIVER SLOTTED



- Blade made of special Be-Br, safe
- Two tone TPR handle, comfortable

PART #	SIZE	LENGHT	⊞
E8942	6×100mm	190.0mm	6
E8943	6×150mm	240.0mm	6
E8944	8×200mm	290.0mm	6
E8945	8×250mm	340.0mm	6

COLD CHISEL



- Made of special Be-Br, safe and durable
- Pliers edge heat treated, strong cutting

PART #	SIZE	LENGHT	
E8922	8"	200.0mm	12

DIAGONAL PLIERS



- Made of Special Be-Br, safe and durable

PART #	SIZE	LENGHT	
E8972	14x160mm	160.0mm	6
E8974	18x200mm	200.0mm	6
E8975	20x300mm	300.0mm	6

DOUBLE-HEAD BUNG WRENCH



- Made of special Be-Br, safe and durable
- Pliers edge heat treated, strong cutting

PART #	SIZE	LENGHT	
E8925	6"	150.0mm	12

LINEMAN'S PLIERS



- Blade made of special Be-Br, safe
- Two tone TPR handle, comfortable

PART #	SIZE	LENGHT	
E8928	8"	200.0mm	12

- Made of Special Be-Br, safe and durable

PART #	LENGHT	
E8982	350.0mm	6

Safety F-shape Wrench



- made of Be-Br

PART #	SIZE	LENGHT	
E8990	30mm	200mm	6
E8991	35mm	250mm	6
E8992	40mm	300mm	6
E8993	45mm	350mm	6
E8994	48mm	375mm	4
E8995	50mm	400mm	4
E8996	55mm	450mm	4
E8997	60mm	500mm	2
E8998	65mm	550mm	2

Safety K-shape Wrench



- made of Be-Br

PART #	SIZE	LENGHT	
E8986	40x50mm	300mm	6
E8987	55x74mm	450mm	6
E8988	70x80mm	600mm	4
E8989	90x100mm	800mm	4

Material	Working Place	Hardness	Torque
Al-Br	No sparkle only tapping in the context of ethylene gas concentrations below 7%	25HRC	≤85Kg/cmf
Be-Br	No sparkle even continuous tapping in the context of hydrogen gas concentration below 21% (Hydrogen gas is more inflammable and explosive than ethylene gas)	35HRC	≤120Kg/cmf



21

ELECTRICAL TOOLS

LONG LIFE SOLDERING IRON



- Suitable for welding in large area and main cables, with different welding nozzles
- High Heat capacity, heat conducting and high efficiency
- Easy-to-change system for heating element

PART #	SIZE	TEMP
E9605	80W	8
E9606	100W	8
E9607	150W	8
E9608	200W	6
E9609	300W	6

LONG LIFE SOLDERING IRON



- Mica heater core.
- Convenient to replace heater core.

PART #	SIZE	HEATER	TIP
E9601	30W	E9611	E9621
E9602	40W	E9612	E9622
E9603	50W	E9613	E9623
E9604	60W	E9614	E9623

DIGITAL SOLERING STATION



Supplementary Soldering Iron Tips

PART #	SIZE	TIPS
E0621	B	
E0622	SB	
E0623	I	
E0627	1.6D	

PART #	SIZE	TIPS
E0628	2.4D	
E0629	3.2D	
E0637	K	
E0638	SK	

DIGITAL SOLERING STATION



- Quick Temperature Raising and Returning, max. 350°C heat up in 30 second
- Intelligentized temperature control circuit, for working under alternating voltage
- Special design, Endurable

PART #	SIZE	TEMP
E0602	60~130W	160~480°C



MICA HEATER/TIPS



PART #	SIZE	FOR #
E9611	30W	E9601
E9612	40W	E9602
E9613	50W	E9603
E9614	60W	E9604
E9621	4mm	E9601. 30W
E9622	5mm	E9602 .40W
E9623	6mm	E9603 E9604 .50W 60W

MICA HEATER



PART #	SIZE	FOR #
T9605	80W	E9605
T9606	100W	E9606
T9607	150W	E9607
T9608	200W	E9608
T9609	300W	E9609
T9615	80W	E9605
T9616	100W	E9606
T9617	150W	E9607
T9618	200W	E9608
T9619	300W	E9609

SOLDER WIRE



Made of lead-tutania alloy, including 63% of lead.

PART #	SIZE	LENGTH
E9742	17g	1.0mm

GLUE STICKS



PART #	SIZE	CONTENTS
E9670	11.2x200mm	6PCS

HOT MELT GLUE GUN



- Pre-heat time:3-5 minute
- Flow rate:8-12g per minute
- CE GS approved

PART #	POWER	VOLTAGE	GLUESTICK
E9663	40W	230V	11.2mm
E9664	60W	230V	11.2mm

WIRE STRIPPER



- Stripping Range: 12,14,16,18,20,22,24A.W.G.

PART #	SIZE	LENGTH
E5803	6"	155.0mm

WIRE STRIPPER



- Grooving Range: 12-10,16-14,22-18A.W.G.
- Stripping Range: 10,12,14,16,18,20-22A.W.G.
- Cutting Range: 8-32,10-24,10-32,6-32,4-40A.W.G.

PART #	SIZE	LENGTH
E5801	8"	200.0mm

WIRE STRIPPER



- Grooving Range: 12-10,16-14,22-18A.W.G.
- Stripping Range: 10,12,14,16,18,20-32A.W.G.
- Cutting Range: 8-32,10-24,10-32,6-32,4-40A.W.G.

PART #	SIZE	LENGTH
E5802	9"	225.0mm

ENDURA®
A Textron Company

AUTOMATIC WIRE STRIPPER



- Reinforced plastic grip, comfortable to use.
- Meet and exceed QB/T 2207-1996.

PART #	SIZE	LENGTH	
E5811	A Type	0.5-1.2-1.6-2.0	6
E5812	B Type	1.0-1.6-2.0-2.6-3.2	6
E5813	C Type	0.9-1.25-2.0-3.5-5.5-8.0	6

CRIMPING TOOL



- Range: 0.5-1.5, 1.5-2.5, 4-6mm².

PART #	SIZE	
E5831	9"	6

CRIMPING TOOL



- Range: 0.5-1.5, 2.5, 4, 6 mm².

PART #	SIZE	
E5835	9"	6

MULTI FUNCTION WIRE STRIPPER



- Stripping Range: 0.5-6mm
- Meet and exceed QB/T 2207-1996.

PART #	SIZE	LENGTH	
E5821	6-1/2"	170mm	6

CRIMPING TOOL



- Range: 0.5, 1, 1.5, 2.5, 4, 6mm².

PART #	SIZE	
E5832	9"	6

CRIMPING TOOL



- Range: 0.15-0.5, 0.5-1.5, 1.5-2.5, 4-6 mm².

PART #	SIZE	
E5836	9"	6

MODULAR CONNECTOR CRIMPING TOOL



- mainly used for electric, internet and wire
- made of High-Grade Alloy Steel, totally hot treated

PART #	SIZE	
E5815	4P	6
E5816	6P	6
E5817	8P	6

CRIMPING TOOL



- Range: 1.73, 6.65, 8.23, 9.14mm².

PART #	SIZE	
E5833	9"	6

CRIMPING TOOL



- Range: 0.5, 1, 1.5, 2.5, 4, 6, 10mm².

PART #	SIZE	
E5837	9"	6

MODULAR CONNECTOR CRIMPING TOOL



- Suitable for 2 in 1 telephone line connector and network line connector.
- Easy to strip wires with cutting and stripping blades.

PART #	SIZE	
E5825	8"	12

CRIMPING TOOL



- Range: 1, 2, 5mm².

PART #	SIZE	
E5834	9"	6

CRIMPING TOOL



- Range: 6.48, 5.36, 3.24, 1.64, 9.1 mm².

PART #	SIZE	
E5838	9"	6

DETECTING SCREWDRIVER



- Blade made of Cr-V. 100-500V AC.
- With clip.
- Super-long life Neon bulb can be used over 20,000 times.

PART #	SIZE	LENGTH	
E6751	140mm	140.0mm	12
E6752	190mm	190.0mm	12

SHARP HEAD TWEEZER



- Made of stainless steel.

PART #	SIZE	LENGTH	
E9712	SHARP	125.0mm	12

WIDE HEAD TWEEZER



- Made of stainless steel.

PART #	SIZE	LENGTH	
E9715	Wide Tip	120.0mm	12

DIGITAL DETECTING SCREWDRIVER



PART #	SIZE	
E6755	135.0mm	12

EXTPA SHARP LONE HEAD TWEEZER



- Made of stainless steel.

PART #	SIZE	LENGTH	
E9713	Specil Sharp Tip	135.0mm	12

SLIGHTLY SHARP HEAD TWEEZER



- Made of stainless steel.

PART #	SIZE	LENGTH	
E9716	Micro Sharp	115.0mm	12

AUTO VOLTAGE TESTER



PART #	SIZE	LENGTH	
E6756	6V-12V-24V	135.0mm	12

EXTPA SHARP SHORT HEADTWEEZER



- Made of stainless steel.

PART #	SIZE	LENGTH	
E9714	Short Tip	120.0mm	12

CVRVED HEAD TWEEZER



- Made of stainless steel.

PART #	SIZE	LENGTH	
E9717	Bent	118.0mm	12

DIGITAL MULTI-METER



DC Voltage: 200mV±0.5%, 2/20/200V/600V±0.8%
 AC Voltage: 200/600V±1.2%
 DC Current: 20µ/200mA±1.2%, 200µ/2mA/20mA±1.0%, 10A±2.0%
 Resistance: 200Ω±1.0%, 2KΩ/20KΩ/200KΩ±0.8%, 2MΩ±1.2%
 Diode Test; Test Condition: Voltage, approx. 2.8V
 Max. Show Value: 1999 (3 1/2) with automatic polarity indication LCD Display.
 Measuring Method: Dual-slope integration A/D converter system.
 Overrange Indication: "1"
 Reading Rate: approx. 2-3 times/sec
 Operating Temperature: 0°C-40°C, ≤75% R.H.
 Storage Temperature: -10°C-50°C, ≤75% R.H.
 Dimension: 138x70x28mm

- Insulated panel.
- Meet and exceed IEC1010-1 CAT III 600V, CAT III 600V.
- Max Transient Voltage, 400V

PART #	SIZE	LENGTH	Weight
E9231	Battery 9V	115g	6

DIGITAL CLAMP METER



- Mini design, suitable for normal measurement of current, voltage and resistance
- 6 functions, 8 optional ranges
- Meet IEC1010-1 CAT III 600V
- 2m drop-proof
- Data hold function
- Overload protection
- Battery power display
- Safety Level: CATII, 3 1/2 digital LCD, max. reading: 1999
- Short-Voltage indicator
- Continuity test function

PART #	SIZE	Weight	Length
E9252	Battery 9v	250g	6

Digital Multi-Meter



Frequency and duty-cycle measuring
 Data Hold and Back Light
 Frequency: 5HZ 5MHZ
 Temperature: -20°C to 1000°C
 AC/DC MA 0.01MA to 4000MA
 AC/DC MA0.01MA to 4000MA
 AC/DC AMP. 0.01AMP to 10AMP.
 Compative Value Manul/Auto Mesuring choice
 Manual/ Auto Capacitance 10PF TO 1000UF
 Resistance/Diode/Buzzer Resistance 0.1 ohm to 40megohm/ Diode Testing, Buzzer Warning
 DC MV 0.1 TO 400MV
 DC Voltage 0.1 to 1000V
 AC Voltage 0.1 to 700MA



Strongly Recommended Functions

- AC/DC voltage, AC/DC current, resistance, capacitance, diode, frequency, temperature measuring, duty-cycle, auto on and off, data hold, etc. RS232 interface connected with computer to record, analyze, process and print data.
- Advanced plastic-injecting panel, insulated.
- Overload-protection function guarantees safety.
- Manual and automatic measuring
- Big LCD display, easy readout.
- Designed and manufactured strictly according to international Electrotechnical Safety Standard.

DIGITAL CLAMP METER



DC Voltage: 1000V(±1.0%)
 AC Voltage: 750V(±1.2%)
 AC Current: 20-200-1000A(±2.0%)
 Resistance: 2K-200K(±1.0%)
 Diode test: 2.8V/1mA
 Frequency: 2KHz(±2.5%)

- High-tech ASS sealing design
- Meet IEC61010-1
- Apply for testing AC Voltage, AC Current
- With overload protection
- With back-light display
- Continuity test function with buzzer for resistance and frequency

PART #	SIZE	Weight	Length
E9253	Battery 9V	400g	6

DIGITAL MULTI-METER



DC Voltage: 400MV-1000V(±0.5%+3)
 AC Voltage: 400MV-1000V(±1%+3)
 DC Current: 400µA-10A(±1.5%+3)
 AC Current: 400µA-10A(±1.5%+3)
 Resistance: 400Ω-40MΩ(±0.5%+2)
 Capacitance: 50MF-200µF(±2%+2)
 10A Fuse; Diode test; Buzzer.
 Max. Show Value: 3999
 Display Size: 69x43mm
 Dimension: 185x87x53mm

- Auto off and on.
- LED display, easy readout.
- Meet and exceed IEC1010-1 CAT III 600V, CAT III 1000V, CAT III 600V.

PART #	SIZE	Weight	Length
E9241	AAA-1.5V	360g	12

DIGITAL MULTI-METER



DC Voltage: 200mV/2V/20V/200V±0.5%/1000V±0.8%
 AC Voltage: 2V/20V/200V±0.8%, 750V±1.2%
 Resistance: 200/20k/200k/2MΩ±0.8%, 20MΩ±1.0%
 DC Current: 2m/20mA±0.8%, 200mA±1.5%, 10A±2.0%
 AC Current: 2mA±1.0%, 200mA±1.8%, 10A±3.0%
 Capacitance: 2n/20n/200n/20µF±4.0%
 Max. Reading: 1999
 Transistor hFE: 1-1000
 Continuity test function
 Diode test

PART #	SIZE	Weight	Length
E9243	Battery 9v	200g	6

DIGITAL MULTI-METER



DC Voltage: 200mV/2V/20V/200V/600±0.7%
 AC Voltage: 200mV/2V/200V/600V±0.8%
 Resistance: 200/2K/20K/200K/2MΩ/20MΩ±1.2%
 Max. Reading: 1999
 Continuity test function
 Diode test
 Touchless voltage detector with audible and visual buzzer
 Adjustable sensitivity for voltage detecting

- Dual-color injected housing
- Auto or Manual Measurement range
- Hold and memory function for max. reading
- Automatic shutdown

PART #	SIZE	Weight	Length
E9234	Battery 9v	200g	6

PROTECTIVE FUNCTION ANALOGUE MULTIMETER



- Suitable to measure DC Voltage, DC Current and DC max. 10A, AC Voltage, resistance, transistor, diodes, LED, battery, short-circuit beep and capacitance (2000µF max.)
- DC Voltage: 0.1/0.5/2.5/10/50/250/1000V 7 setting
- DC Current: 50µA/2.5mA/25mA/250mA/10A 5 setting
- AC Voltage: 10/50/250/1000V 4 setting
- Resistance: 1/10/1k/10k 4 setting
- Battery: 1.5/9V 2 setting
- Capacitance: C1(RX1K) (2000µF); C2: 0.025-0.25-25µF (3 setting)
- Standard working environment: 23°C±5°C, humidity<75%RH.
- Work environment: 0°C-40°C, humidity<90%RH
- Storage condition: -10°C-50°C, humidity<80%RH
- Dimension: 150(L)x97(W)x36(H)mm
- Capacitor Testing Accessory CT-1 (0.025/0.25/25µF 3 setting)

PART #	SIZE	Length
E9237	Battery 9v	6

CVRVEO BLADE ELECTRICAL KNIFE



- Made of premium grade Mn steel.
- Blade hardness>HRC56

PART #	SIZE	LENGTH
E7021	80mm	121.0mm

STRAIGHT BLADE ELECTRICAL KNIFE



- Made of premium grade Mn steel.
- Blade hardness>HRC56

PART #	SIZE	LENGTH
E7022	80mm	121.0mm

ENDURA®
 A Textron Company

DIGITAL DETECTING SCREWDRIVER



- Can test 5 kind electric tension:12V、36V、55V、110V、220V
- Have Induction test functionality
- LED Panel collaborated with Blue LED bulbs
- Night Vision

PART#	VOLTAGE	LENGTH	
E6754	12-250V	140mm	12

SOLDER ABSORBER



- High efficiency to absorb remaining soldering tin.
- PTFE nozzle withstands high temperature and solvent.

PART #	LENGTH	
E9671	195.0mm	12

SOLDER AID TOOLS



- 1-Brush
- 1-Fork
- 1-Awl
- 1-Scraper
- 1-Hook
- 1-Push Bar

PART #	CONTENTS	
E9753	6PCS	12

BATTERY TESTER



- batteries is not necessary.
- be exclusively used in testing battery such as D,C,AA,AAA,6F22
- can display the remaining battery power

PART #	
E9256	6

SOLDER ABSORBER



- Single hand operation.
- PLCC with 20 and 84 feet can be extracted.
- Suitable for PLCC components.

PART #	LENGTH	
E9672	202.0mm	12

VINYL ELECTRICAL TAPE



- Excellent insulation, bear the voltage
- Good stickiness

PART #	SIZE	COLOR	DIAMETER	
E9721	18mmx9m	Black	58.0mm	60
E9722	18mmx9m	Red	58.0mm	60
E9723	18mmx9m	Yellow	58.0mm	60
E9724	18mmx9m	Green	58.0mm	60

IC CLIP



- Heat treated, high elasticity,
- Stainless steel, wrapped with P.V.C. comfortable to use.

PART #	
E9752	12

PLCC EXTRACTOR



- Single hand operation.
- PLCC with 20 and 84 feet can be extracted.
- Suitable for PLCC components.

PART #	
E9751	12

ESD FLUJD DISPXENSER



- Anti-static

PART #	SIZE	
E9747	60ml	12

ESD ADJUSTABLE WRIST STRAP



- Anti-static, adjustable.

PART #	
E9745	12

BALL



PART #	
E9746	12

ENDURA®
A Textron Company

ENDURA®
A Textron Company

ENDURA®
A Textron Company

22

HAMMER & STRIKING TOOLS



6PC.CR-V PUNCH SET



- 2-Chipping chisel 12x130mm,15x150mm
- 2-Conic punch 3x120mm,4x150mm
- 1-Center Punch 4x120mm
- 1-Triangular Punch 4x130mm
- Made from Cr-V steel

PART #	CONTENTS	△△	📦
E1563	6PCS	0.73kg	6

6PC.CR-V PUNCH SET



- Size: 3pcs 3*150mm,5*150MM,8*150MM
- 3pcs 3*150mm,5*150MM,8*150MM
- Made from Cr-V steel

PART #	CONTENTS	△△	📦
E1564	6PCS	0.75kg	6

27PC LETTER PUNCH



- Special alloy steel, HRC 60.
- Germany style font.

PART #	SIZE	LENGTH	📦
E9494	4.0mm	60.0mm	12
E9495	5.0mm	60.0mm	12
E9496	6.0mm	65.0mm	12
E9498	8.0mm	68.0mm	12

9PC NUMBER PUNCH



- Special alloy steel, HRC 60.
- Germany style font.

PART #	SIZE	LENGTH	📦
E9484	4.0mm	60.0mm	12
E9485	5.0mm	60.0mm	12
E9486	6.0mm	65.0mm	12
E9488	8.0mm	68.0mm	12

6PC.CR-V PUNCH SET



- Size: 3pcs 2*150mm,3*150MM,4*150MM
- 3pcs 5*150mm,6*150MM,8*150MM
- Made from Cr-V steel

PART #	CONTENTS	△△	📦
E1565	6PCS	0.75kg	6

8PC. CR-V PUNCH SET



- Size 4pcs 8*150mm, 10*165mm,13*175mm, 16*200mm
- 2pcs 3*120mm, 5*150mm
- 1pcs 5*150mm
- 1pcs 5*150mm
- Made from Cr-V steel

PART #	CONTENTS	△△	📦
E1566	8PCS	0.92kg	4

TAPER PUNCH



- Made from Cr-V steel.

PART #	SIZE	Ø	LENGTH	
E9421	3x120mm	10.0mm	120.0mm	12
E9422	3x150mm	10.0mm	150.0mm	12
E9425	4x150mm	12.0mm	150.0mm	12
E9426	5x150mm	12.0mm	150.0mm	12
E9428	8x150mm	12.0mm	150.0mm	12

CAPE PUNCH



- Made from Cr-V steel.

PART #	SIZE	Ø	LENGTH	
E9438	4x130mm	10.0mm	130.0mm	12

WRECKING BAR



- Cr-V alloy steel. Painted, ant rust.

PART #	SIZE	LENGTH	
E9448	20X750mm	750.0mm	6

PIN PUNCH



- Made from Cr-V steel.

PART #	SIZE	Ø	LENGTH	
E9430	2x150mm	10.0mm	150.0mm	12
E9431	3x150mm	10.0mm	150.0mm	12
E9434	4x150mm	10.0mm	150.0mm	12
E9432	5x150mm	10.0mm	150.0mm	12
E9439	6x150mm	12.0mm	150.0mm	12
E9433	8x150mm	12.0mm	150.0mm	12

COLD CHISEL



- Made from Cr-V steel.

PART #	SIZE	Ø	LENGTH	
E9416	8x150mm	8.0mm	150.0mm	12
E9417	10x165mm	10.0mm	165.0mm	12
E9418	13x175mm	13.0mm	175.0mm	12
E9419	16x200mm	16.0mm	200.0mm	12
E9441	12x130mm	10.0mm	130.0mm	12
E9442	15x150mm	12.0mm	150.0mm	12
E9443	18x200mm	14.0mm	200.0mm	12

WRECKING BAR



- Cr-V alloy steel. Painted, ant rust.

PART #	SIZE	LENGTH	
E9405	16X400mm	400.0mm	6
E9449	22X800mm	800.0mm	6

CENTER PUNCH



- Made from Cr-V steel.

PART #	SIZE	Ø	LENGTH	
E9437	3x120mm	8.0mm	120.0mm	12
E9435	4x120mm	10.0mm	120.0mm	12
E9436	5x150mm	12.0mm	150.0mm	12

COLD CHISEL



- Made from Cr-V steel.

PART #	SIZE	Ø	LENGTH	
E9444	22x250mm	17x11mm	250.0mm	12
E9445	22x300mm	17x11mm	300.0mm	12
E9446	22x350mm	17x11mm	350.0mm	12
E9447	26x350mm	20x12mm	350.0mm	6

FORGED NAIL PULLER



- Made from quality material
- Suitable for opening case.

PART #	SIZE	
E7218	18"	6

BALL PEIN HAMMER



- Quality carbon steel hammer head
- Smooth finishing and anti-rust oil plated.
- Special insertion process, hammer head tight.

PART #	SIZE	LENGTH	
E7101	8oz	290mm	6
E7102	12oz	315mm	6
E7103	16oz	330mm	6
E7104	24oz	353mm	6
E7105	32oz	370mm	6

CLAW HAMMER



- TPR plastic handle, comfortable and anti-shock
- Quality carbon steel hammer head, good finishing.

PART #	SIZE	LENGTH	
E7221	8oz	290mm	6
E7222	12oz	305mm	6
E7223	16oz	330mm	6
E7224	20oz	340mm	6

ENGINEERING HAMMER



- TPR plastic handle, comfortable and anti-shock
- Quality carbon steel hammer head, good finishing.

PART #	SIZE	LENGTH	
E7241	200g	275mm	6
E7242	300g	312mm	6
E7243	400g	315mm	6

CLAW HAMMER



- Quality carbon steel hammer head
- Smooth finishing and anti-rust oil plated.
- Special insertion process, hammer head tight.

PART #	SIZE	LENGTH	
E7111	8oz	290mm	6
E7112	12oz	305mm	6
E7113	16oz	330mm	6
E7114	20oz	340mm	6

BALL PEIN HAMMER



- TPR plastic handle, comfortable and anti-shock
- Quality carbon steel hammer head, good finishing.

PART #	SIZE	LENGTH	
E7231	8oz	290mm	6
E7233	16oz	315mm	6
E7234	24oz	340mm	6

FINISHING HAMMER



- Quality walnut handle.
- Smooth finishing and anti-rust oil plated.
- Quality Zinc alloy hammer head.
- Special insertion process, hammer head tight.
- Red PU soft end, hardness Shore A80 ± 5
- White PA nylon end, hardness Shore A90 ± 5

PART #	SIZE	
E7261	28mm	6
E7262	35mm	6
E7263	45mm	6
E7264	60mm	6

ENGINEERING HAMMER



- Quality carbon steel hammer head
- Smooth finishing and anti-rust oil plated.
- Special insertion process, hammer head tight.

PART #	SIZE	LENGTH	
E7121	200g	270mm	6
E7122	300g	307mm	6
E7123	400g	310mm	6
E7124	500g	340mm	6

CLAW HAMMER



- Quality carbon steel hammer head
- Smooth finishing and anti-rust oil plated.

PART #	SIZE	LENGTH	
E7131	8oz	250mm	6
E7133	16oz	312mm	6

PEAD BELOW HAMMER



- Industrial grade rubber material.
- Durable and anti-oil
- Comfortable handle, iron ball inside the hammer head, anti-rebound.

PART #	SIZE	
E7255	1lb	6
E7256	2lb	6
E7257	2.5lb	6
E7258	3lb	6

COPPER HAMMER



- Durable, suitable for installation work.
- Quality red copper hammer head.

PART #	SIZE	WEIGHT
E7246	16oz	6
E7247	32oz	6

SLEDGE HAMMER



- Smooth finishing and anti-rust oil plated.
- Special insertion process, hammer head tight.

PART #	SIZE	LENGTH	WEIGHT
E7251	2lb	320mm	6
E7252	3lb	350mm	3

WELDING HAMMER



- Special design for soldering add.
- Comfortable handle, durable, 3 end strike function.

PART #	SIZE	WEIGHT
E7215	300mm	6

AXE



- With draw function
- Special TPR handle, strong and durable.

PART #	SIZE	WEIGHT
E7211	20oz	6

RUBBER HAMMER



- Quality rubber hammer head
- Special insertion process, hammer head tight.

PART #	SIZE	LENGTH	WEIGHT
E7271	50mm(8oz)	280mm	6
E7272	65mm(16oz)	300mm	6
E7274	75mm(24oz)	330mm	6

PLASTIC HAMMER HEAD



- Special design for soldering add.
- Comfortable handle, durable, 3 end strike function.

PART #	SIZE	LENGTH	WEIGHT
E7265	28mm	Soft	6
E7267	35mm	Soft	6
E7269	45mm	Soft	6
E7276	60mm	Soft	6
E7277	28mm	Hard	6
E7268	35mm	Hard	6
E7278	45mm	Hard	6
E7279	60mm	Hard	6

23

HOIST TOOLS

CHAIN BLOCK



Special supply

- 3m chain.
- Light, for one hand operation, safe.
- For heavy duty, all steel structure.

PART #	SIZE	CHAIN#	HIGHT	WEIGHT
T0522	1T	1	3.0m	10.0Kg
T0524	2T	2	3.0m	13.8Kg
T0525	3T	2	3.0m	24.0Kg
T0526	5T	2	3.0m	36.0Kg
T0527	10T	4	3.0m	78.0Kg
T0529	20T	8	3.0m	162.0Kg

LEVER BLOCK



- Chrome plated, light, easy to handle, good accompany for lifting.
- Special technology, can lift at any high, highly efficient.
- Length of chain 1.5 meter, can be customized.

PART #	SIZE	CHAIN#	HIGHT	WEIGHT
T0532	0.75T	1	1.5m	6.3kg
T0533	1.5T	1	1.5m	11.0kg

HYDRAULIC JACK



- Comply to ANSI/ASME safety tandard.
- Plastic package

PART #	CAPACITY	MIN	MAX	ADJUST
E9541	2 TON	181mm	116mm	48mm
E9542	4 TON	194mm	118mm	60mm
E9543	6 TON	216mm	127mm	70mm

SCISSLRS JACK



- Light and easy to handle.
- Comply to ANSI standard and GS/CE/TUV standard.

PART #	CAPACITY	MIN	MAX
E9531	1 TON	88mm	380mm
E9532	1.5TON	95mm	390mm

HYDRAULIC JACK



- Comply to GS/CE/TUV standard.

PART #	CAPACITY	MIN	MAX
E9551	2 TON	130mm	345mm
E9552	3 TON	130mm	345mm

24

AUTO MAINTENANCE & REPAIR TOOLS

AUTOMOTIVE SPECIAL TOOL

OILER



- Special design, durable.

PART #	SIZE	QTY
E9504	250cc	1

MULTI-PURPOSE GREASE



- Quality grease. Operation temperature -20°C to -120°C

PART #	SIZE	QTY
E9528	400cc	1

HAND GREASE GUN



- Strong alloy steel head.
- Strong spring for even and smooth injection.
- Iron ball inside design, anti back flow.
- Easy to operate even when handle is not completely open.
- Design for more air expel.
- Multiply injection ways.

PART #	SIZE	MAX	QTY
E9512	400CC	10000PSI	1

HAND GREASE GUN



- Strong and transparent body, tested to be able to endure 2ton pression., air tight.
- Anti-rust, for longtime use. Made from aluminum harder than Zinc alloy.

PART #	SIZE	MAX	QTY
E9514	400CC	10000PSI	1

GREASE COUPLER



- Ball inside, anti back flow

PART #	SIZE	QTY
E9521	Flat Head	12
E9526	Pointed Head	12

OILER



- Bronze connector on both end of the soft pipe, rubber material inside the pipe
- Can bear high pressure. Can be used for over 30000 times.

PART #	SIZE	CAPACITY	QTY
E9501	6oz	170cc	1

SUCKTION GUN



- Easy operation.

PART #	SIZE	QTY
E9503	400cc	1

HAND GREASE GUN



- Strong and transparent body, tested to be able to endure 2ton pression., air tight.
- Anti-rust, for longtime use. Made from aluminum harder than Zinc alloy.
- For narrow space, one hand operation.

PART #	SIZE	MAX	QTY
E9513	400CC	10000PSI	1

HAND GREASE GUN



- Muntiple grease way.
- Strong Zinc alloy head.
- Strong Spring ensure smooth injection.
- Iron ball inside, anti back flow.

PART #	SIZE	MAX	QTY
E9511	400CC	10000PSI	1

HAND GREASE GUN

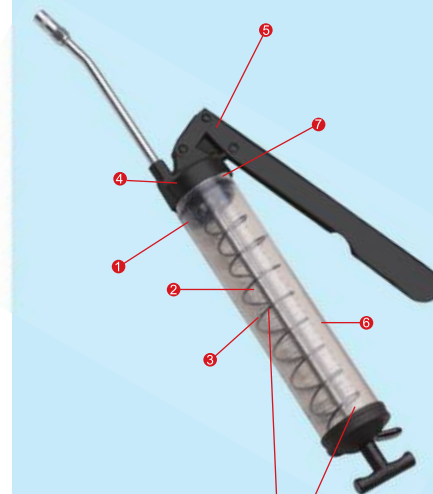

Strong and transparent tube



Strong and transparent body, durable for 2 ton pressure.

- 1 Strong and transparent body, air tight.
- 2 Shape memory material
- 3 Anti rust, for long time operation
- 4 Made from aluminum harder than Zinc alloy.
- 5 Special structure, grease speed and quantity up graded
- 6 Operation temperature -20°C to 66°C
- 7 Rubber piston, anti-leaking.

AUTOMOTIVE SPECIAL TOOL

VALVE SEAL RING PLIER



PART #	LENGTH	
E0711	250MM	6

OIL FILTER WRENCH



• Wide tape and wide handle, easy to use.

PART #	RANG	
E0724	87.5-95mm	12

STEEL MAGNETIC TOOL HOLDER



• Alloy steel, max torque: 1000-12000 Gauss

PART #	SIZE	MAX	
E0734	18"	30Lbs(13.64Kg)	6

PISTON RING COMPRESSOR



PART #	SIZE	LENGTH	RANG	
E0714	3"	75mm	53-175mm	1
E0715	4"	100mm	60-175mm	1

OIL FILTER WRENCH



• For narrow space operation, can be turned 90 degree.

PART #	RANG	
E0725	87.5-116mm	12

5PC.PICK UP TOOL KITS



- 2-8lbs pick up head with handle
- 1-8 Lbs pick up head with handle
- 1-3.5 Lbs pick up head.
- 1-2 1/4" inspection mirror

PART #	CONTENTS	
E0736	5PCS	6

OIL FILTER WRENCH



- For oil filter difficult to disassemble.
- Special handle, more powerful.

PART #	RANG	
E0721	63-116mm	12

MAGNETIC PARTS TRAY



• Stainless steel, strong magnetic, easily collect small parts.

PART #	SIZE	
E0731	6"	6

MAGNETIC PICK UP



• Strong magnetic, easily pick up fallen parts.

PART #	SIZE	LENGTH	
E9748	18"	575mm	12

2WAY OIL FILTER WRENCH



• Suitable for 1/2" Dr driving tool or 12/16" wrench
Suitable for the disassembly of filter within diameter 120mm

PART #	RANG	
E0722	63-102mm	12

MAGNETIC PARTS TRAY



• Stainless steel, strong magnetic, easily collect small parts.

PART #	SIZE	
E0732	5.5"x9.5"	6

INSPECTION MIRROR



• Can be extended from 8" to 35"
Alloy steel, bulk heat treatment, hardness guarantee

PART #	DIAMETER	
E0737	1-1/4"	6

BALL JOINT PULLER



• Alloy steel, bulk heat treatment, hardness guarantee.

PART #	LENGTH	OPENING	
E0191	40.0mm	20.0mm	1

PITMAN ARM PULLER



• Bulk heat treatment, hardness guarantee.

PART #	LENGTH	OPENING	
E0194	64.0mm	33.0mm	1

VZZZINSPECTION MIRROR



• Can be extended from 9-3/8" to 36-3/8"

PART #	DIAMETER	
E0738	2-1/4"	6

BALL JOINT PULLER



• Bulk heat treatment, hardness guarantee.

PART #	LENGTH	OPENING	
E0192	50.0mm	19.0mm	1

11PC .STEERING WHEEL PULLER



• Bulk heat treatment, hardness guarantee.

PART #	CONTENTS	
E0195	11PCS	1

PICK UP TOOL



• Can be extended from 6-1/2" to 33"

PART #	MAGNETIC	
E0739	5Lbs	6

PITMAN ARM PULLER



• Bulk heat treatment, hardness guarantee.

PART #	LENGTH	OPENING	
E0193	55.5mm	28.0mm	1

13PC.HARMONIC BALANCE PULLER



• Bulk heat treatment, hardness guarantee

PART #	CONTENTS	
E0196	13PCS	1

6PCS. AUTO BODY REPAIR KIT



• Six pcs auto repair kit
One flat iron cushion for free.

PART #	CONTENTS	
E0748	6PCS	1

OIL FILTER WRENCH



• Stainless steel, adjustable.

PART #	SIZE	
E0758	70-120mm	12

DROP FORGED COIL SPRONG COMPRESSOR



- Alloy steel, bulk heat treatment, hardness guarantee
- 1/2" DR socket for 1/2" driver or wrench

PART #	SIZE	6
E0743	370mm	6

PISTON RING PLIERS



- For piston ring operation
- Alloy steel, electroplating.
- PVC handle, comfortable.

PART #	SIZE	6
E0741	50-100mm	6

WHEEL WEIGHT TOOL



- Alloy steel, electroplating.
- PVC handle, comfortable.

PART #	6
E0745	6

DISC BRAKE PISTON COMPRESSOR



- For disc brake installation
- Alloy steel, bulk heat treatment, hardness guarantee.

PART #	6
E0744	6

UNIVERSAL BALL JOINT PULLER



- For break system of auto mobile
- Cr-V steel, high hardness

PART #	6
E0742	6

SPARK PLUG TERMINAL PLIERS



- Alloy steel, electroplating.
- PVC handle, comfortable.

PART #	6
E0746	6

NUT SOCKET



PART #	FOR	6
E4573	Absorber	6

INSPECTION LAMP



- Length of power cord: 10 meters, cold-resistant -40°c-50°c.

PART #	SIZE	POWER	BULB	6
E0749	10m	220v	60w	6

VALVE SPRING COMPRESSOR



- Alloy steel, bulk heat treatment, hardness guarantee,PVC comfortable handle.
- Automatic lock system. Suitable size 45-145mm

PART #	SIZE	6
E0747	45-145mm	6

IN STALL SOCKET



- Cr-V steel, customized for volks wagen auto

PART #	FOR	6
E4571	Front Shock Absorber	6

CLAMP PLIERS



- Filter, cooling system, soft pipe holding
- Suitable for newest GM, CV connector.

PART #	FOR	12
E0752	250mm	12

OIL FILTER WRENCH



PART #	RANGE	6
E0726	53-108.0mm	6

IN STALL SOCKET



- Cr-V steel, customized for volks wagen auto

PART #	FOR	6
E4572	Back Shock Absorber	6

AL' HAND STRAP WRENCH



- Belt length 700mm

PART #	SIZE	6
E5634	12"	6

TIRE GAUGES



PART #	12
E9763	12

BELT WRENCH



- Belt Length 540mm

PART #	SIZE	6
E5630	9"	6

CHAIN WRENCH



- Chain length: 500mm

PART #	SIZE	6
E5636	9"	6

GASKET SCRAPER



PART #	LENGTH	6
E0761	275mm	6

NEW PRODUCTS

CARTRIDGE WRENCHES



PART #	SIZE	📦
E0727	55-75mm	12
E0728	75-95mm	12

OIL FILTER WRENCHES



65mm14 For: TOYOTA, NISSAN, ALTO, LEXUS, DIAHATSU, NAPA etc--
 74mm15 For: GM, AUDI, BUICK, SATURN etc--
 76mm14 For: VW, PORSCHE, MOPAR, MERCEDES, BENZ, BMW etc--
 80mm15 For: HONDA, NISSAN, MAZDA, ISUZU, TOYOTA, SUBARU etc--
 90mm15 For: HONDA ACCORD, MITSUBISHI, MOPAR, ISUZU etc--
 93mm15 For: GM, FRAM, HASTINGS, OPEL, MAZDA, VOLVO, MITSUBISHI, PUROLATOR, VW, PORSCHE, RENAULT, FORD, AUDI, HONDA etc--

PART #	SIZE	📦
E0784	65mm/14	6
E0785	74mm/15	6
E0786	76mm/14	6
E0787	80mm/15	6
E0788	90mm/15	6
E0789	93mm/15	6

UNIVERSAL BALL JOINT EXTRACTORS



Open: 20-22mm
 Height: 30mm, 50mm
 For: FORD, BMW, VOLVO, OPEL, VW, AUDI, MERCEDES-BENZ etc--

PART #	📦
E0778	1

5PCS HOOK & PICK SET



PART #	SIZE	📦
E0776	5PCS	12

MECHANIC'S STETHOSCOPES



PART #	📦
E9795	6

BEARING SEPARATORS



PART #	SIZE	📦
E0729	30-50mm	1
E0730	50-75mm	1

5PCS HOOK & PICK SET



PART #	SIZE	📦
E0777	37PCS	1

DOOR UPHOLSTERY REMOVERS



PART #	SIZE	LENGTH	📦
E0760	9mm	235mm	12

BRUSH



PART #	📦
E9701	12

GEAR PULLERS

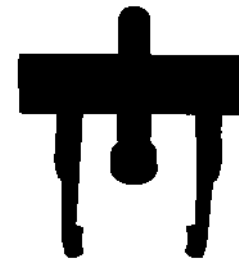

- Puller length: 100mm
- Width: 22mm

PART #	SIZE	📦
E0197	40-90mm	1

BEARING SEPARATORS ASSEMBLY



PART #	CONTENTS	📦
E0779	12PCS	1

ENDURA®
 A Textron Company



AUTOMOTIVE SPECIAL TOOL

AUTOMOTIVE SPECIAL TOOL

OXYGEN SENSOR SOCKET



- Suitable for Ford, GM, Chrysler automobile oxygen sensor

PART #	DRIVER	SIZE	📦
E0766	1/2"	7mm	6

SNAP IN TIRE VALVE INSTALLER

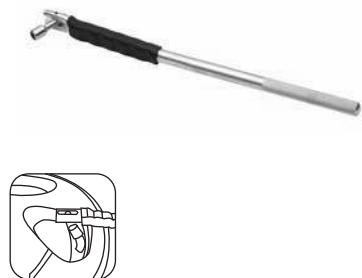

PART #	📦
E0770	6

MAGIATIC PICK UP



PART #	SIZE	ΔΔ	📦
E9735	930x440x105mm	6.0kg	1

BODY PRY BAR



PART #	Description	LENGTH	📦
E9828	L Type	380.0mm	2
E9829	S Type	380.0mm	2

5PC HANDY REMOVER SET

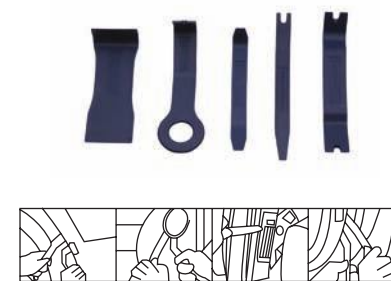

PART #	📦
E0763	6

UNIVERSAL CALIPER



PART #	📦
E0767	6

VW/AUDI V-BELT NUT SOCKET



PART #	📦
E0772	6

ADJUSTABLE FUEL TANK LID REMOVER



PART #	DRIVER	📦
E0768	3/8"	6

MAGIATIC PICK UP



- Special design for comfortable operation
- Strong wheels.

PART #	SIZE	ΔΔ	📦
E9736	1030x440x105mm	6.5kg	1

BODY WEDGE TOOL



PART #	Description	WxH	📦
E9832	Small	48x110mm	6
E9833	Mid	70x110mm	6
E9834	Big	92x110mm	6
E9835	Ball	48x110mm	6

5PC VALVE SPRING COMPRESSOR



PART #	📦
E0764	6

A/C COMPRESSOR CLUTCH REMOVER KIT



PART #	📦
E0769	6

A/C FUEL LINE DISCONNECT TOOL SET



PART #	CONTENTS	📦
E0773	7PCS	6

STEEL CAR SEAT



PART #	SIZE	ΔΔ	📦
E9737	440x360x365mm	5.5kg	1

BODY PRY BAR



PART #	LENGTH	📦
E9823	300.0mm	4
E9824	450.0mm	4
E9825	600.0mm	4
E9826	750.0mm	4
E9827	900.0mm	4

BODY WEDGE TOOL



PART #	Description	📦
E9836	L Type	4
E9837	T Type	4

11PC VALVE SEAL REMOVAL&INSTALLER KIT



PART #	📦
E0765	6

RADIO REMOVE TOOL KIT



PART #	📦
E0771	6

25

FLASHLIGHTS



FLASHLIGHT

LED



- Made of premium grade aluminium alloy. Resistant to water, shake and eroding.
- Super bright/white LED, never get hot or need replacing.
- Can be used over 80000 hours.
- Power and electricity saving. Can be continuously used over 15 hours.

PART #	SIZE	🔋
E9332	Battery3*1#	6

ALUMINUM LED FLASHLIGHT



- Made of Aluminum Alloy resistant to water, sake and eroding.
- Imported LED Bulb, generate no heat, Continuous working≥2.5 hours(according to the battery capacity)
- 2 #5 battery operation, handy and bright.
- Function: 100%bright/50%bright/flash/OFF
- Long life LED up to 100000 hours
- Longest shooting distance 10m

PART #	SIZE	LED	POWER	🔋
E9315	2AA	1 CREE 1W LED	4.5V	12

FLASHLIGHT



- Sumsung super bright Led bulb, long life, energy saving.
- Aluminium alloy body Resistant to water, shake and eroding.

PART #	SIZE	LED	POWER	🔋
E9313	Battery1*5#	1W	3.3V	6
E9314	Battery2*5#	1W	3.3V	6

MULTI RECHARGABLE FLASHLIGHT



- Long life LED up to 100000 hours

PART #	SIZE	LED	POWER	🔋
E9355	4400mAH	1LED	3W	1

HALOGEN LAMP



- E9319 For E9371, E9374
- E9320 For E9372, E9375, E9376

PART #	POWER	VOLTAGE	🔋
E9319	150W	220-240V	10
E9320	500W	220-240V	10

PILE THREAD TAPE



- Made of 100% PTFE in accordance with international standard.
- Eroding resistant, aging-resitant.

PART #	SIZE	🔋
E9768	20mx12mmx0.1mm	50
E9770	20mx18mmx0.1mm	50
E9771	20mx24mmx0.1mm	50

TOOL BOX



PART #	POWER	LXWXH	🔋
E9765	60PCS	117x83x26mm	6

FLASHLIGHT



- 3 button batteries.
- Swivels a full 360: fits in narrow space.
- Super bright/white LED. Never get hot or need replacing.
- Can be used over 80000 hours.
- Power and electricity saving. Can be continuously used over 30 hours.

PART #	SIZE	Quantity
E9341	Button Battery	6

LED WORK TORCH



- CREE 1.5wLED, Max.110LM, Max.500mts
- Inner 3.7V/1500mAh rechargeable lead-acid battery
- Recharge Voltage: AC110—240V
- Recharge Hours: 3

PART #	Quantity
E9363	1

HANDY WORK LIGHT



- Halogen Lamp, standard operation 2000 hours
- Iron bar stand, electrostatic spray finishing, anti-erosion, anti-dust.
- Toughened glass cap with iron bar protection net.
- Aluminium reflection back, shooting angle adjustable.
- Suitable for equipment repair, home decoration etc.

• Warning: do not touch the glass, high temperature.

PART #	POWER	VOLTAGE	Quantity
E9371	150W	220V	1
E9372	500W	220V	1

FLASHLIGHT



- 3 AAA batteries.
- Swivels a full 360: fits in narrow space.
- Super bright/white LED. Never get hot or need replacing.
- Can be used over 80000 hours.
- Power and electricity saving. Can be continuously used over 30 hours.
- With clip, easy to take along.

PART #	SIZE	Quantity
E9342	Battery3*7#	6

WORK TORCH



- 16x LED bulbs, super bright
- With 4 warning LED at the end cover of handle
- Continuous working hour: > 10 hour.
- With inner 6V 4AH rechargeable lead-acid battery.
- Recharge Voltage: AV 220V-50HZ or DC 12V (with automobile's cigarette plug)
- Recharge hours: 10 - 12 hours
- In accordance with ROHS, CE.

PART #	Quantity
E9367	1

HANDY WORK LIGHT



- Halogen Lamp, standard operation 2000 hours
- Iron bar stand, electrostatic spray finishing, anti-erosion, anti-dust.
- Toughened glass cap with iron bar protection net.
- Aluminium reflection back, shooting angle adjustable.
- Suitable for equipment repair, home decoration etc.

• Warning: do not touch the glass, high temperature.

PART #	POWER	VOLTAGE	Quantity
E9374	150Wx2	220V	1

FLASHLIGHT



- Top-mounted hook swivels a full 360.
- 30 H.I.O LED never gets hot or need replacing, with over 80000 hour warranty.
- With charge indication light, red when charging, green when full charged.
- With 9V and 200V Nickel hydrogen charger.
- Base with lodestone, easy to adsorb.
- Power and electricity saving. Can be continuously used over 2 hours.

PART #	Quantity
E9361	6

ALUMINUM LED FLASHLIGHT



- Long life LED up to 100000 hours

PART #	SIZE	LED	POWER	Quantity
E9325	3AAA	1LED	3W	6
E9327	3D	1LED	3W	6

ALUMINUM LED FLASHLIGHT



- Long life LED up to 80000 hours

PART #	SIZE	LED	Quantity
E9335	1AAA	1LED	6
E9336	3AAA	12LED	6
E9337	2AA	5LED	6
E9338	2D	24LED	6

PEN TYPE FLASHLIGHT



- Long life LED up to 100000 hours

PART #	SIZE	LED	POWER	Quantity
E9345	2AAA	1 LED	1W	6

HEAD FLASHLIGHT



- 10 LED
- 3AAA batteries.
- Can be used 2-3 hours.

PART #	SIZE	Quantity
E9351	Battery3*7#	6

FLASHLIGHT BULB



- E9305 for E9301, E9302
- E9306 for E9302, E9303
- E9307 for E9304, E9311, E9312
- E9308 for 9362
- E9309 for E9331, E9332

PART #	SIZE	LENGTH	Quantity
E9305	2.4V/0.75A	2PCS(Bulb)	24
E9306	2.4V/0.3A	2PCS(Bulb)	36
E9307	1.2V/0.3A	2PCS(Bulb)	12
E9308	3.6V/500mA	2PCS(Bulb)	12
E9309		2PCS(LED Bulb)	12

CONSOLE WORK LIGHT



- Enhanced Iron bar stand, height adjustable, electrostatic spray finishing, anti-erosion, anti-dust.
- Halogen Lamp, standard operation 2000 hours
- Toughened glass cap with iron bar protection net.
- Aluminium reflection back, shooting angle adjustable.
- Widely used for equipment repair, home decoration etc.

• Warning: do not touch the glass, high temperature.

PART #	POWER	VOLTAGE	Quantity
E9375	500W	220V	1

CONSOLE WORK LIGHT



- Enhanced Iron bar stand, height adjustable, electrostatic spray finishing, anti-erosion, anti-dust.
- Halogen Lamp, standard operation 2000 hours
- Toughened glass cap with iron bar protection net.
- Aluminium reflection back, shooting angle adjustable.
- Widely used for equipment repair, home decoration etc.

• Warning: do not touch the glass, high temperature.

PART #	POWER	VOLTAGE	Quantity
E9376	500Wx2	220V	1

Endura Exhibition Stand

Size: 2200X910X450MM
2500X910X450MM



Endura Exhibition Hall



Standard Exhibition And Assortment Display











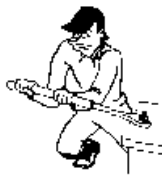

Quality Guarantee and After-service Clauses

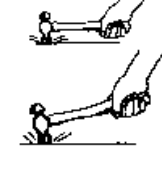
Quality Guarantee and After-service Clauses

All ENDURA products are manufactured in accordance with National Tool Manufacturing Standard and International Tool Manufacturing Standard. Within 360 days after you purchase ENDURA tools, you can have them fixed for free or exchanged for a new one at the local dealer's, provided products cannot be normally used owing to their own quality problem. Products broken owing to non-quality problem can be offered excellent service at the local dealer's. Buyers will be charged according to the toll standard established by ENDURA. In order to guarantee efficient and effective service to you, dealers authorized by ENDURA should conform to the following service principles:

- A. Dealers should give priority to the matter that customers can continue their work even if the tools go wrong.
- B. Buyers should submit the related purchasing receipt if they expect after-service.
- C. Free service doesn't apply to rust, desquamation, nick on surface, broken plastic grips and broken packing material, for example, paper box, plastic box, paper card, etc.
- D. Free service doesn't apply to broken products caused by natural wear and tear.
- E. Free service doesn't apply to broken products caused by non-proper use. The maintenance lots can charge buyers according to the repairing standard established by ENDURA.
- F. For those failing to be normally used with exchanged accessories, buyer can have them exchanged.
- G. Buyers who expect after service should fill in the complete standard Quality Service Card.
- H. Users should properly use the tools according to the product instructions.

! Properly Use the Tools

				
Never use cheater bars, esp. for ordinary wrench.	Never use hammer on wrench, screwdriver, etc.	Use hammer head to strike.	Working at a height, be careful not to drop the tools to hurt passers-by.	Adjust wrench size in case wrench is subject to slip.
				
Use proper size screwdriver on fasteners.	Never use hammer with loose head.	Never use hammer on ordinary screw driver handle.	Never strike with hammer side.	Never use two hammers to strike each other.